



Anisotropic Heat Transfer Through Woven Carbon Fibers

Introduction

Composite materials such as carbon-fiber-reinforced polymer (CFRP) have outstanding properties. It is a lightweight material with high stiffness and high temperature tolerance and therefore used in aerospace industry, civil engineering, and also for high-end sports goods.

Carbon crystals form flat ribbons that are bundled together and woven in different structures as required by the application area. The bundles have anisotropic material properties. For thermal properties this means that the thermal conductivity along the fiber axis is much higher than perpendicular to it.

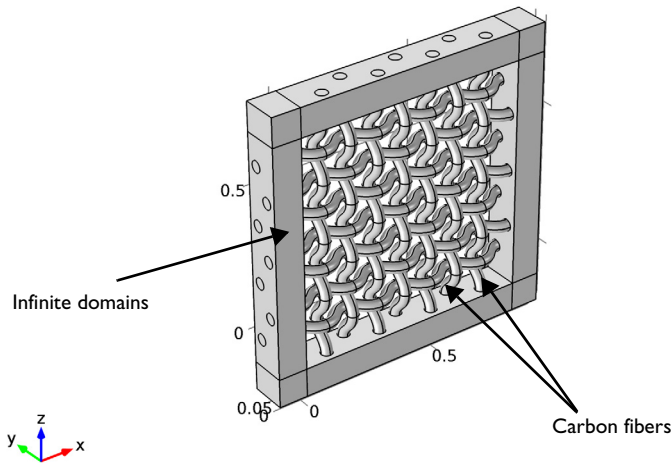

Figure 1: Model geometry: fibers embedded in an epoxy matrix (hidden) with infinite element domain.

In COMSOL Multiphysics, implementing anisotropic properties is straightforward in the global coordinate system, which is set by default. However, in the present case, an anisotropic thermal conductivity needs to be defined along woven fibers where the global coordinate system is inapplicable. The curvilinear coordinate system provides the possibility to create a coordinate system following the curves of a geometry in which anisotropic material properties or anisotropic physics can be defined.

This tutorial shows how to use the curvilinear coordinates interface and how to apply it to define anisotropic thermal conductivity.

Model Definition

The model represents a cutout of a carbon-fiber-reinforced polymer. The geometry used in this case is shown in [Figure 1](#). The fiber bundles have circular cross-sections and are embedded in a matrix made of epoxy.

The “infinite domains” truncate the geometry to model a few fibers only. With the Heat Transfer Module you can assign them as Infinite Element Domains and thus suppress boundary effects. Without the Heat Transfer Module, the boundary conditions at the outer side affects the solution, in this case the maximum temperature. Increase the number of fibers to reduce these effects.

MATERIAL PROPERTIES

The material properties are summarized in [Table 1](#).

TABLE 1: MATERIAL PROPERTIES.

MATERIAL PROPERTY	EPOXY	CARBON (CORE)	CARBON (INFINITE DOMAIN)
Thermal conductivity	0.2 W/(m·K)	{60,4,4} W/(m·K)	60 W/(m·K)
Density	1200 kg/m ³	1500 kg/m ³	1500 kg/m ³
Heat capacity at constant pressure	1000 J/(kg·K)	1000 J/(kg·K)	1000 J/(kg·K)

Note the syntax of the thermal conductivity for carbon (core). In the general case of an anisotropic thermal conductivity, it is a second order tensor. In the present case, the tensor is diagonal.

$$k = \begin{pmatrix} k_{xx} & k_{xy} & k_{xz} \\ k_{yx} & k_{yy} & k_{yz} \\ k_{zx} & k_{zy} & k_{zz} \end{pmatrix} = \begin{pmatrix} 60 & 0 & 0 \\ 0 & 4 & 0 \\ 0 & 0 & 4 \end{pmatrix}$$

Note that the conductivity is higher in the fibers direction and lower in perpendicular direction. The coordinate system used for k must then provide an x -component following the shape of the fibers. The Curvilinear Coordinates interface provides appropriate tools to create such a base vector system.

CURVILINEAR COORDINATES

Three predefined methods and a user-defined method are available to set up a curvilinear coordinate system. Further details can be found in the section *The Curvilinear Coordinates Interface* in the *COMSOL Multiphysics Reference Manual*. Here you use the diffusion method which solves Laplace's equation resulting in a scalar potential. It is the same as solving the stationary heat transfer equation with temperature boundary conditions resulting in a temperature gradient and forming the first base vector of the new coordinate system. The second base vector is specified manually and the cross product of both forms the third base vector.

Figure 2 shows the base vector system for a single fiber.

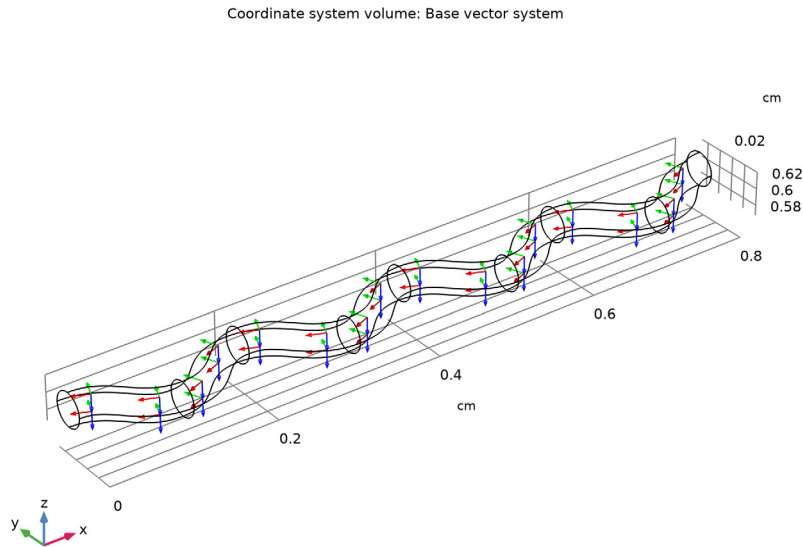

Figure 2: Curvilinear coordinate system from diffusion method.

Alternatively the Flow Method is available, which results in a vector potential. This is equivalent to solving Stokes flow (also known as creeping flow) where the obtained velocity field forms the first base vector. The third option is to choose the Elasticity Method for solving an eigenvalue problem.

If the **Create base vector system** option is selected, the new curvilinear system is available as input for the **Coordinate System Selection** list and thus providing new (x , y , and z) coordinates.

BOUNDARY CONDITIONS

For the curvilinear coordinates interface, the inlet and outlet boundaries define the direction of the first base vector. The heat transfer analogy consists of setting a high temperature at the inlet and a low temperature at the outlet. All other boundaries are thermally insulated walls.

For the heat transfer interface, a constant temperature boundary condition is set at the outermost walls. A boundary heat source described with a Gaussian pulse is applied to the center of the geometry and a convective cooling boundary condition is applied on both sides.

INFINITE ELEMENTS

To truncate the geometry the Infinite Element Domain feature can be used. Boundary conditions applied to these elements can be imagined as boundary conditions at an infinite distance of the modeling domain. So it does not affect the solution of this particular problem. This works by scaling the width of the domain to be much larger than the original geometry.

Results and Discussion

From the **Curvilinear Coordinates** interface a new coordinate system is obtained as shown in [Figure 2](#). The temperature distribution on the surface shows a high temperature at the center where the maximum of the Gaussian function is located and decreases with

increasing distance from the center. The temperature drop of 293 K, as specified in the boundary conditions, occurs mainly in the Infinite Element Domains.

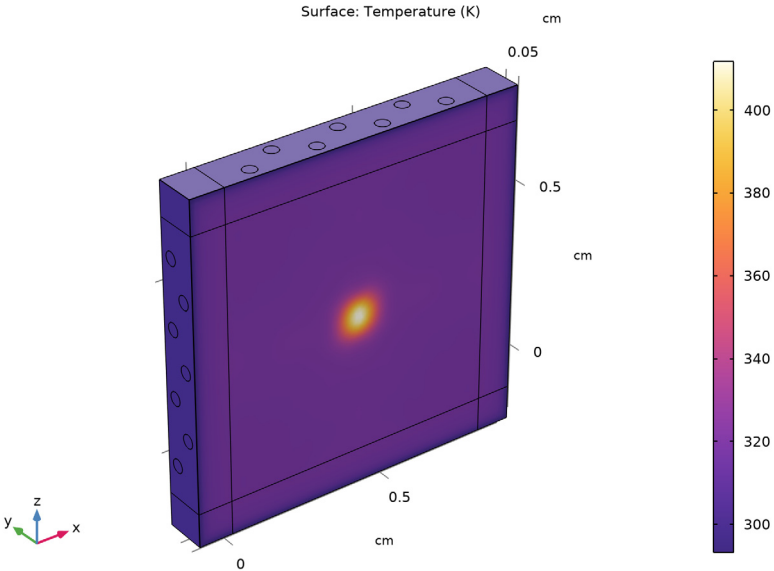

Figure 3: Temperature distribution on the surface.

Figure 4 shows clearly that the heat spreads preferentially along the fiber axis.

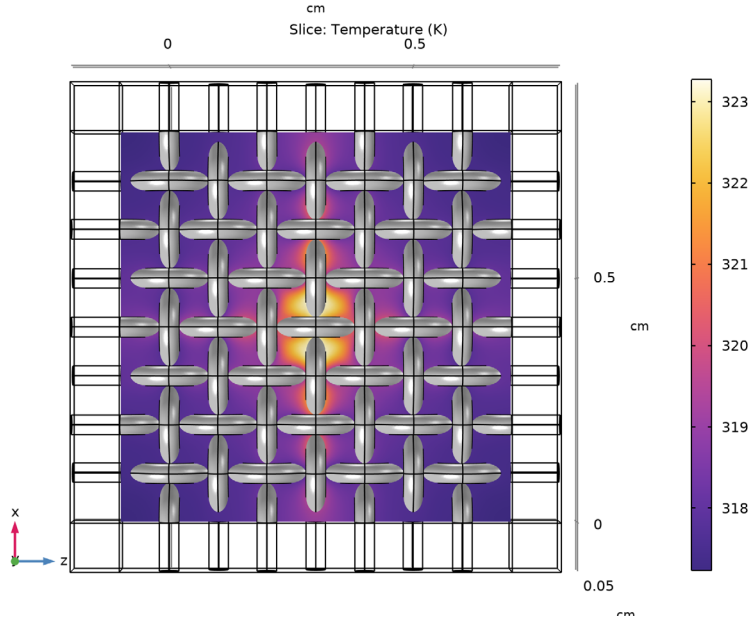

Figure 4: Temperature at the center plane and fiber structure (gray).

Notes About the COMSOL Implementation

This tutorial demonstrates how to use the **Curvilinear Coordinates** interface for defining anisotropic thermal conductivity. Hence, the instructions focus on this part and start with loading the file `carbon_fiber_geom.mph`. The steps needed to create this file are quite complex. This document does not go into details but provides a short summary instead.

The geometry sequence calls geometry subsequences depending on the global parameter q . The subsequences define different cross-sections and can be found under the **Global Definitions** node. Call the elliptical cross-section with $q = 1$ and the rectangular cross-section with $q = 2$.

All subsequent geometry features are based on these subsequences. Inside some of the features, a selection of geometric entities is created automatically by selecting the **Create Selections** option. Instead of selecting objects manually, these selections are used as input in the following geometry node. This approach ensures that all geometry operations adapt and produce the desired geometry automatically, even if a geometry parameter changes.

Selections are also used on the finalized geometry to ensure that physical properties are assigned to the intended entities. These selections are defined under **Component 1 > Definitions**. They are used to automatically set up boundary and domain conditions as well as the mesh. The resulting model is consistent for any choice of parameters. The extra time needed to set up this kind of geometry sequence and to define selections is regained through an accelerated physics modeling and meshing process.

Application Library path: Heat_Transfer_Module/Tutorials,_Conduction/
carbon_fibers_infinite_elements

Modeling Instructions

ROOT

Start with loading the model file that contains the geometry and selections used throughout the modeling process.

APPLICATION LIBRARIES

- 1 From the **File** menu, choose **Application Libraries**.
- 2 In the **Application Libraries** window, select **COMSOL Multiphysics > Heat Transfer > carbon_fibers_geom** in the tree.
- 3 Click  **Open**.



ROOT

Click the  **Zoom Extents** button in the **Graphics** toolbar.

COMPONENT 1 (COMP1)

Add the **Curvilinear Coordinates** interface for the fibers.

ADD PHYSICS

- 1 In the **Home** toolbar, click  **Add Physics** to open the **Add Physics** window.
- 2 Go to the **Add Physics** window.
- 3 In the tree, select **Mathematics > Curvilinear Coordinates (cc)**.
- 4 Click **Add to Component 1** in the window toolbar.
- 5 In the **Home** toolbar, click  **Add Physics** to close the **Add Physics** window.

CURVILINEAR COORDINATES (CC)

- 1 In the **Settings** window for **Curvilinear Coordinates**, locate the **Domain Selection** section.
- 2 From the **Selection** list, choose **Fibers (Core)**.
- 3 Locate the **Settings** section. Select the **Create base vector system** check box.

According to the **Curvilinear Coordinates** section, the second basis vector is specified manually. The *y* direction feels natural.

Coordinate System Settings I

- 1 In the **Model Builder** window, under **Component 1 (comp1)>Curvilinear Coordinates (cc)** click **Coordinate System Settings I**.
- 2 In the **Settings** window for **Coordinate System Settings**, locate the **Settings** section.
- 3 From the **Second basis vector** list, choose **y-axis**.

Diffusion Method I

- 1 In the **Physics** toolbar, click  **Domains** and choose **Diffusion Method**.
Wall is the default boundary condition where the normal component of the vector field is zero. The direction of the first basis vector is specified with inlet and outlet boundary conditions.
- 2 In the **Settings** window for **Diffusion Method**, locate the **Domain Selection** section.
- 3 From the **Selection** list, choose **Fibers (Core)**.

Inlet I

- 1 In the **Physics** toolbar, click  **Attributes** and choose **Inlet**.
- 2 In the **Settings** window for **Inlet**, locate the **Boundary Selection** section.
- 3 From the **Selection** list, choose **Inlets**.

Diffusion Method I

In the **Model Builder** window, click **Diffusion Method I**.

Outlet I

- 1 In the **Physics** toolbar, click  **Attributes** and choose **Outlet**.
- 2 In the **Settings** window for **Outlet**, locate the **Boundary Selection** section.
- 3 From the **Selection** list, choose **Outlets**.

MESH I

Now, build a suitable mesh manually. Start with meshing the fibers.

Free Triangular 1

- 1 In the **Mesh** toolbar, click  **Boundary** and choose **Free Triangular**.
- 2 In the **Settings** window for **Free Triangular**, locate the **Boundary Selection** section.
- 3 From the **Selection** list, choose **Inlets**.

Distribution 1

- 1 Right-click **Free Triangular 1** and choose **Distribution**.
- 2 In the **Settings** window for **Distribution**, locate the **Edge Selection** section.
- 3 From the **Selection** list, choose **Inlet Edges**.
- 4 Locate the **Distribution** section. In the **Number of elements** text field, type 2.
- 5 Click  **Build Selected**.

Swept 1

- 1 In the **Mesh** toolbar, click  **Swept**.
- 2 In the **Settings** window for **Swept**, locate the **Domain Selection** section.
- 3 From the **Geometric entity level** list, choose **Domain**.
- 4 From the **Selection** list, choose **Fibers (Core)**.

Distribution 1

- 1 Right-click **Swept 1** and choose **Distribution**.
- 2 In the **Settings** window for **Distribution**, locate the **Domain Selection** section.
- 3 From the **Selection** list, choose **Fibers (Core)**.
- 4 Locate the **Distribution** section. In the **Number of elements** text field, type 8.

5 Click  **Build Selected.**

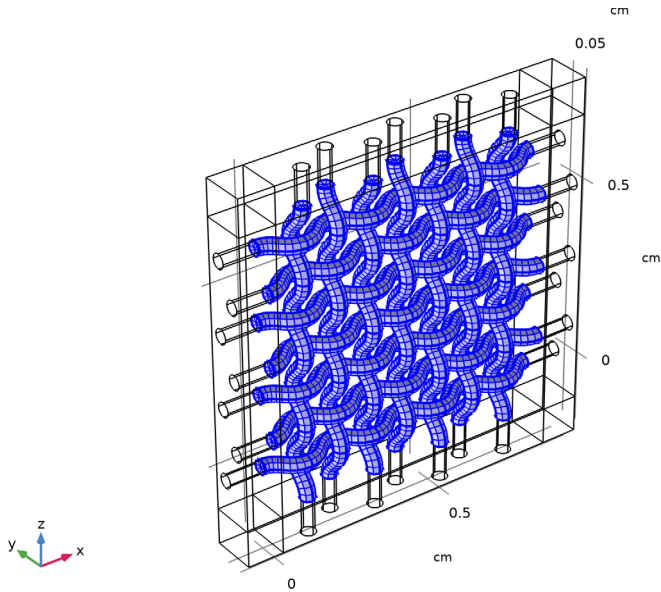

Free Tetrahedral 1

- 1 In the **Mesh** toolbar, click  **Free Tetrahedral.**
- 2 In the **Settings** window for **Free Tetrahedral**, locate the **Domain Selection** section.
- 3 From the **Geometric entity level** list, choose **Domain**.
- 4 Select Domain 12 only.

Swept 2

- 1 In the **Mesh** toolbar, click  **Swept.**
- 2 In the **Settings** window for **Swept**, locate the **Domain Selection** section.
- 3 From the **Geometric entity level** list, choose **Domain**.
- 4 From the **Selection** list, choose **Infinite Element Domains**.

Distribution 1

- 1 Right-click **Swept 2** and choose **Distribution**.
- 2 In the **Settings** window for **Distribution**, locate the **Distribution** section.
- 3 In the **Number of elements** text field, type 3.

Mesh the remaining parts with a free swept mesh.

4 Click  **Build All**.

The final mesh looks like this.

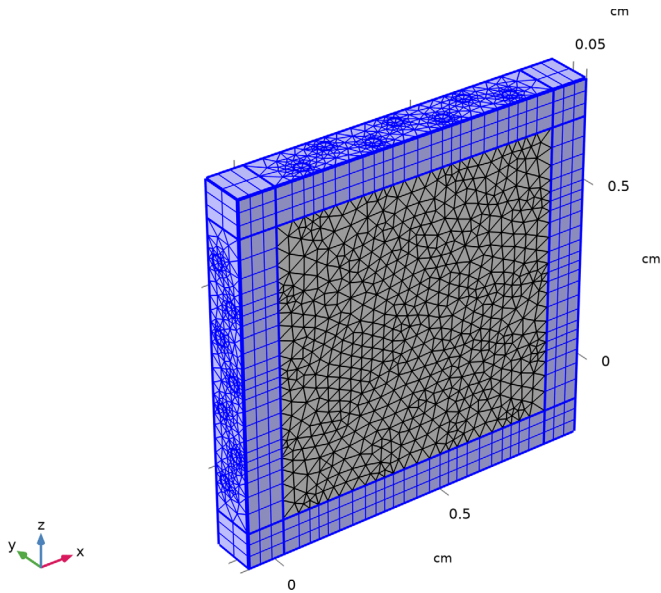

ADD STUDY

1 In the **Home** toolbar, click  **Add Study** to open the **Add Study** window.

2 Go to the **Add Study** window.

Add a stationary study to compute the new coordinate system with the **Diffusion Method**.

3 Find the **Studies** subsection. In the **Select Study** tree, select **General Studies>Stationary**.

4 Click **Add Study** in the window toolbar.

5 In the **Home** toolbar, click  **Add Study** to close the **Add Study** window.

STUDY 1

Step 1: Stationary

In the **Home** toolbar, click  **Compute**.

RESULTS



Vector Field (cc)

The default plots show the coordinate system with streamlines for the vector field. To create the plot shown in [Figure 2](#), add a selection to the dataset. The plot group will then use this subset of the whole geometry only.



Study 1/Solution 1 (sol1)

In the **Model Builder** window, expand the **Results>Datasets** node, then click **Study 1/Solution 1 (sol1)**.

Selection

- 1 In the **Results** toolbar, click  **Attributes** and choose **Selection**.
- 2 In the **Settings** window for **Selection**, locate the **Geometric Entity Selection** section.
- 3 From the **Geometric entity level** list, choose **Domain**.
- 4 Click  **Paste Selection**.
- 5 In the **Paste Selection** dialog box, type 20, 34, 54, 68, 88, 102, 122, 136 in the **Selection** text field.
- 6 Click **OK**.

Coordinate System Volume 1

- 1 In the **Model Builder** window, expand the **Coordinate system (cc)** node, then click **Coordinate System Volume 1**.
- 2 In the **Settings** window for **Coordinate System Volume 1**, locate the **Positioning** section.
- 3 Find the **x grid points** subsection. In the **Points** text field, type 16.
- 4 Find the **y grid points** subsection. In the **Points** text field, type 2.
- 5 Find the **z grid points** subsection. In the **Points** text field, type 2.
- 6 In the **Coordinate system (cc)** toolbar, click  **Plot**.
- 7 Click the  **Go to Default View** button in the **Graphics** toolbar.

Now, add the **Heat Transfer in Solids** interface to the component.

ADD PHYSICS

- 1 In the **Home** toolbar, click  **Add Physics** to open the **Add Physics** window.
- 2 Go to the **Add Physics** window.
- 3 In the tree, select **Heat Transfer>Heat Transfer in Solids (ht)**.
- 4 Find the **Physics interfaces in study** subsection. In the table, clear the **Solve** check box for **Study 1**.

5 Click **Add to Component I** in the window toolbar.

6 In the **Home** toolbar, click  **Add Physics** to close the **Add Physics** window.

HEAT TRANSFER IN SOLIDS (HT)

Click the  **Zoom Extents** button in the **Graphics** toolbar.

DEFINITIONS

Infinite Element Domain I (ieI)

1 In the **Definitions** toolbar, click  **Infinite Element Domain**.

2 In the **Settings** window for **Infinite Element Domain**, locate the **Domain Selection** section.

3 From the **Selection** list, choose **Infinite Element Domains**.

In order to apply a heat source right in the center of the model, the **Mass Properties** feature is used. It computes the center of mass, which is automatically the center of the geometry.

Mass Properties I (massI)

1 In the **Model Builder** window, right-click **Definitions** and choose **Physics Utilities> Mass Properties**.

2 In the **Settings** window for **Mass Properties**, locate the **Source Selection** section.

3 From the **Selection** list, choose **Fibers (Core)**.

Define a heat source via a local variable, which is defined on the boundary only. Use the mass properties variable for the center of mass to apply the source term exactly in the center.

Variables I

1 In the **Definitions** toolbar, click  **Local Variables**.

2 In the **Settings** window for **Variables**, locate the **Variables** section.

3 In the table, enter the following settings:

Name	Expression	Unit	Description
Q_in	$1e5[W/m^2]*\exp(-5e6[1/m^2]*((x-mass1.CMX)^2+(z-mass1.CMZ)^2))$	W/m ²	Boundary heat source

In the next section, you define the materials according to the [Material Properties](#) section.

MATERIALS

Epoxy

- 1 In the **Materials** toolbar, click  **Blank Material**.
- 2 In the **Settings** window for **Material**, type Epoxy in the **Label** text field.
- 3 Locate the **Material Contents** section. In the table, enter the following settings:

Property	Variable	Value	Unit	Property group
Thermal conductivity	k_{iso} ; $k_{ii} = k_{iso}$, $k_{ij} = 0$	0.2	W/(m·K)	Basic
Density	ρ	1200	kg/m ³	Basic
Heat capacity at constant pressure	C_p	1000	J/(kg·K)	Basic

Carbon

- 1 In the **Materials** toolbar, click  **Blank Material**.
- 2 In the **Settings** window for **Material**, type Carbon in the **Label** text field.
- 3 Locate the **Geometric Entity Selection** section. From the **Selection** list, choose **Fibers**.
- 4 Locate the **Material Contents** section. In the table, enter the following settings:

Property	Variable	Value	Unit	Property group
Thermal conductivity	$\{k_{11}, k_{22}, k_{33}\}$; $k_{ij} = 0$	{60, 4, 4}	W/(m·K)	Basic
Density	ρ	1500	kg/m ³	Basic
Heat capacity at constant pressure	C_p	1000	J/(kg·K)	Basic

Carbon (Infinite Element Domain)

- 1 In the **Materials** toolbar, click  **Blank Material**.
- 2 In the **Settings** window for **Material**, type Carbon (Infinite Element Domain) in the **Label** text field.
- 3 Locate the **Geometric Entity Selection** section. From the **Selection** list, choose **Fibers (Infinite Element Domain)**.

4 Locate the **Material Contents** section. In the table, enter the following settings:

Property	Variable	Value	Unit	Property group
Thermal conductivity	k_{iso} ; $k_{ii} = k_{iso}$, $k_{ij} = 0$	60	W/(m·K)	Basic
Density	ρ	1500	kg/m ³	Basic
Heat capacity at constant pressure	C_p	1000	J/(kg·K)	Basic

Add a second **Heat Transfer in Solids** node for the fibers and choose the curvilinear system as reference system. This way the thermal conductivity is high along the fiber axis and low perpendicular to it.

HEAT TRANSFER IN SOLIDS (HT)

In the **Model Builder** window, under **Component 1 (comp1)** click **Heat Transfer in Solids (ht)**.

Solid 2

- 1 In the **Physics** toolbar, click  **Domains** and choose **Solid**.
- 2 In the **Settings** window for **Solid**, locate the **Domain Selection** section.
- 3 From the **Selection** list, choose **Fibers (Core)**.
- 4 Locate the **Coordinate System Selection** section. From the **Coordinate system** list, choose **Curvilinear System (cc) (cc_cs)**.

Set up the boundary conditions, consisting in a heat source, a convective heat flux accounting for cooling, and a fixed temperature at the very outer boundaries of the infinite domain.

Boundary Heat Source 1

- 1 In the **Physics** toolbar, click  **Boundaries** and choose **Boundary Heat Source**.
- 2 In the **Settings** window for **Boundary Heat Source**, locate the **Boundary Selection** section.
- 3 From the **Selection** list, choose **Heat Source Boundary**.
- 4 Locate the **Boundary Heat Source** section. In the Q_b text field, type Q_{in} .

Heat Flux 1

- 1 In the **Physics** toolbar, click  **Boundaries** and choose **Heat Flux**.
- 2 In the **Settings** window for **Heat Flux**, locate the **Boundary Selection** section.
- 3 From the **Selection** list, choose **Cooling Boundaries**.
- 4 Locate the **Heat Flux** section. From the **Flux type** list, choose **Convective heat flux**.



5 In the h text field, type 10.

Temperature 1

- 1 In the **Physics** toolbar, click  **Boundaries** and choose **Temperature**.
- 2 In the **Settings** window for **Temperature**, locate the **Boundary Selection** section.
- 3 From the **Selection** list, choose **Temperature Boundaries**.

The first study was used to compute the curvilinear system. Add a second study to solve for the heat transfer only. Refer to **Study 1** in the **Values of Dependent Variables** section by selecting the solution as input for the variables not solved in this second study. This way the new coordinate system, which is initially unknown by **Study 2**, can be used for the heat transfer computation.

ADD STUDY

- 1 In the **Home** toolbar, click  **Add Study** to open the **Add Study** window.
- 2 Go to the **Add Study** window.
- 3 Find the **Studies** subsection. In the **Select Study** tree, select **General Studies>Stationary**.
- 4 Find the **Physics interfaces in study** subsection. In the table, clear the **Solve** check box for **Curvilinear Coordinates (cc)**.
- 5 Click **Add Study** in the window toolbar.
- 6 In the **Home** toolbar, click  **Add Study** to close the **Add Study** window.

STUDY 2

Step 1: Stationary

- 1 In the **Settings** window for **Stationary**, click to expand the **Values of Dependent Variables** section.
- 2 Find the **Values of variables not solved for** subsection. From the **Settings** list, choose **User controlled**.
- 3 From the **Method** list, choose **Solution**.
- 4 From the **Study** list, choose **Study 1, Stationary**.
- 5 In the **Home** toolbar, click  **Compute**.

RESULTS

Temperature (ht)

The default temperature plot shows the temperature distribution on the surface (Figure 3).

To create [Figure 4](#) follow the steps below.

Surface 1

- 1 In the **Results** toolbar, click  **More Datasets** and choose **Surface**.
- 2 In the **Settings** window for **Surface**, locate the **Data** section.
- 3 From the **Dataset** list, choose **Study 2/Solution 2 (sol2)**.
- 4 Locate the **Selection** section. From the **Selection** list, choose **Fiber Walls**.

Temperature at Middle Slice

- 1 In the **Results** toolbar, click  **3D Plot Group**.
- 2 In the **Settings** window for **3D Plot Group**, type Temperature at Middle Slice in the **Label** text field.
- 3 Locate the **Data** section. From the **Dataset** list, choose **Study 2/Solution 2 (sol2)**.

Slice 1

- 1 In the **Temperature at Middle Slice** toolbar, click  **Slice**.
- 2 In the **Settings** window for **Slice**, click **Replace Expression** in the upper-right corner of the **Expression** section. From the menu, choose **Component 1 (comp1)>Heat Transfer in Solids>Temperature>T - Temperature - K**.
- 3 Locate the **Plane Data** section. From the **Plane** list, choose **zx-planes**.
- 4 In the **Planes** text field, type 1.
- 5 Locate the **Coloring and Style** section. From the **Color table** list, choose **HeatCameraLight**.

Selection 1



- 1 In the **Temperature at Middle Slice** toolbar, click  **Selection**.
- 2 In the **Settings** window for **Selection**, locate the **Selection** section.
- 3 From the **Selection** list, choose **Core Domains**.

Temperature at Middle Slice

In the **Model Builder** window, under **Results** click **Temperature at Middle Slice**.

Surface 1

- 1 In the **Temperature at Middle Slice** toolbar, click  **Surface**.
- 2 In the **Settings** window for **Surface**, locate the **Expression** section.
- 3 In the **Expression** text field, type 1.
- 4 Locate the **Data** section. From the **Dataset** list, choose **Surface 1**.
- 5 Click to expand the **Title** section. From the **Title type** list, choose **None**.

- 6 Locate the **Coloring and Style** section. From the **Coloring** list, choose **Uniform**.
- 7 From the **Color** list, choose **Gray**.
- 8 In the **Temperature at Middle Slice** toolbar, click  **Plot**.
- 9 In the **Graphics** window toolbar, click ▼ next to  **Go to Default View**, then choose **Go to ZX View**.
- 10 Click the  **Zoom Extents** button in the **Graphics** toolbar.

