



# Heat Generation in a Disc Brake

## *Introduction*

---

Cars need brakes for obvious reasons, and you do not want these to fail. Brake failure can be caused by many things, one of which is the overheating of the brake's disc. This example models the heat generation and dissipation in a disc brake of an ordinary car during panic braking and the following release period. When the driver is pressing down on the brakes, kinetic energy is transformed into thermal energy. If the brake discs overheat, temperature overload can change the material properties of the brake causing it to fade. Braking power already starts to fade at temperatures above 600 K. This is why it is so important during the design-stages to simulate the transient heating and convective cooling to figure out what the minimum interval between a series of brake engagements is.

In this application, an 1,800 kg car is traveling at 25 m/s (90 km/h or about 56 mph), until the driver suddenly panic brakes for 2 seconds. At that point the eight brake pads slow the car down at a rate of  $10 \text{ m/s}^2$  (assuming the wheels do not skid against the road). Upon braking for two seconds the driver releases the brake, leaving the car traveling at 5 m/s for eight seconds without engaging the brakes. The questions to analyze with the model are:

- How hot do the brake discs and pads get when the brake is engaged?
- How much do the discs and pads cool down during the rest that follows the braking?

## Model Definition

Model the brake disc as a 3D solid with shape and dimensions as in [Figure 1](#). The disc has a radius of 0.14 m and a thickness of 0.013 m.

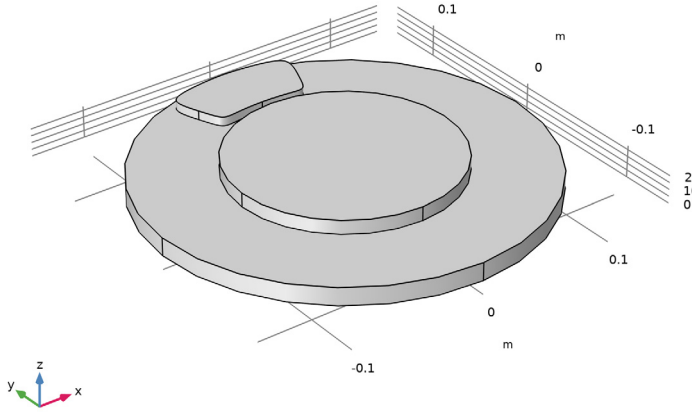

*Figure 1: Model geometry, including disc and pad.*

The model also includes heat conduction in the disc and the pad through the transient heat transfer equation. The heat dissipation from the disc and pad surfaces to the surrounding air is described by both convection and radiation. [Table 1](#) summarizes the thermal properties of the materials used in this application ([Ref. 1](#)).

TABLE 1: MATERIAL PROPERTIES.

PROPERTY	DESCRIPTION	DISC	PAD	AIR
$\rho$ (kg/m <sup>3</sup> )	Density	7870	2000	1.170
$C_p$ (J/(kg·K))	Heat capacity at constant pressure	449	935	1100
$k$ (W/(m·K))	Thermal conductivity	82	8.7	0.026
$\varepsilon$	Surface emissivity	0.28	0.8	-

After 2 s, contact is made at the interface between the disc and the pad. Neglecting drag and other losses outside the brakes, the brakes' retardation power is given by the negative of the time derivative of the car's kinetic energy:

$$P = -\frac{d}{dt}\left(\frac{mv^2}{2}\right) = -mv\frac{dv}{dt}$$

Here  $m$  is the car's mass (1800 kg) and  $v$  denotes its speed. [Figure 2](#) shows the profile of  $v$  and [Figure 3](#) shows the corresponding acceleration profile.

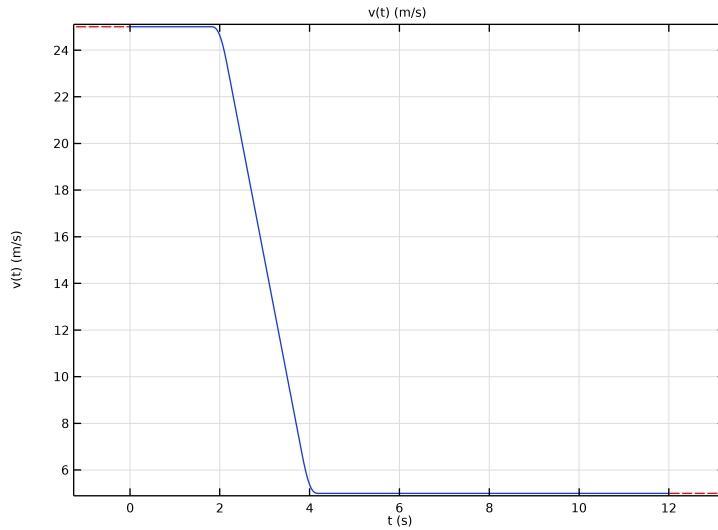

*Figure 2: Velocity profile of the disc.*

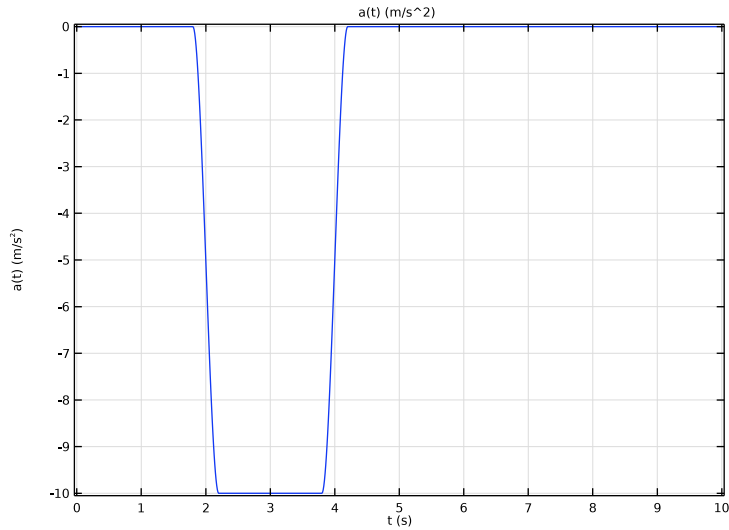

*Figure 3: Acceleration profile of the disc.*

At one of the eight brakes, the frictional heat source is:

$$P_b = \frac{P}{8} = -\frac{1}{8}mv \frac{dv}{dt}$$

The contact pressure between the disc and the pad is related to the frictional heat source per unit area,  $Q_b = P_b/A$ , according to:

$$p = \frac{Q_b}{\mu v}$$

where the friction coefficient  $\mu$  is here equal to 0.3.

The disc and pad dissipate the heat produced at the boundary between the brake pad and the disc by convection and radiation. This example models the rotation as convection in the disc. The local disc velocity vector is

$$\mathbf{v}_d = \frac{v}{R}(-y, x)$$

At the end of the computation, produced and dissipated heat can be recovered using the relations

$$W_{\text{prod}} = \int_0^{t_0} Q_{\text{prod}} dt$$

$$W_{\text{diss}} = \int_0^{t_0} Q_{\text{diss}} dt$$
(1)

## Results and Discussion

The surface temperatures of the disc and the pad vary with both time and position. At the contact surface between the pad and the disc the temperature increases when the brake is engaged and then decreases again as the brake is released. You can best see these results in *COMSOL Multiphysics* by generating an animation. Figure 4 displays the surface temperatures just before the end of the braking. A “hotspot” is visible at the contact between the brake pad and disc, just at the pad’s edge. This is the area that could overheat to the point of brake failure or fade. The figure also shows the temperature decreasing along the rotational trace after the pad. During the rest, the temperature becomes significantly lower and more uniform in the disc and the pad.

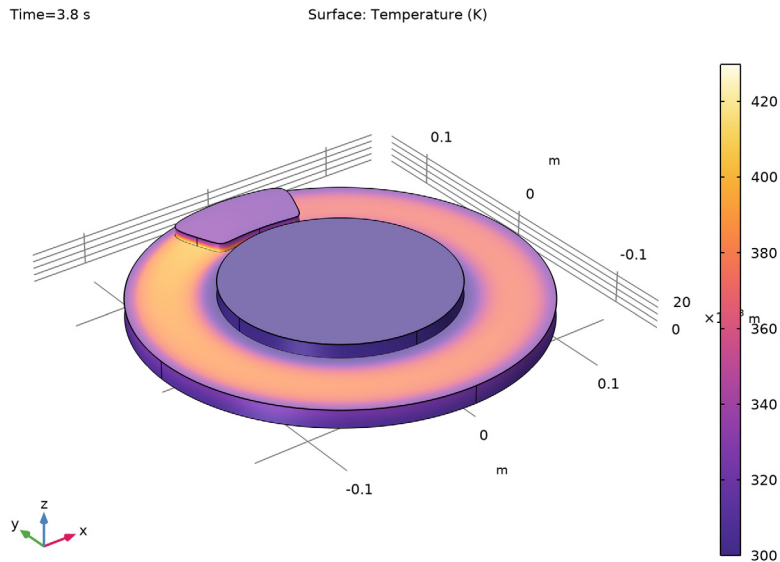

Figure 4: Surface temperature of the brake disc and pad just before releasing the brake ( $t = 3.8$  s).

To investigate the position of the hotspot and the time of the temperature maximum, it is helpful to plot temperature versus time along the line from the center to the pad's edge shown in [Figure 5](#). The result is displayed in [Figure 6](#). You can see that the maximum temperature is approximately 430 K. The hotspot is positioned close to the radially outer edge of the pad. The highest temperature occurs approximately 1 s after engaging the brake.

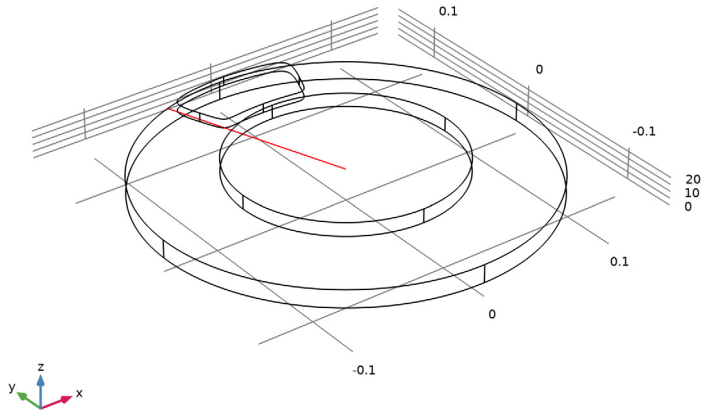

Figure 5: The radial line probed in the temperature vs. time plot in Figure 6.

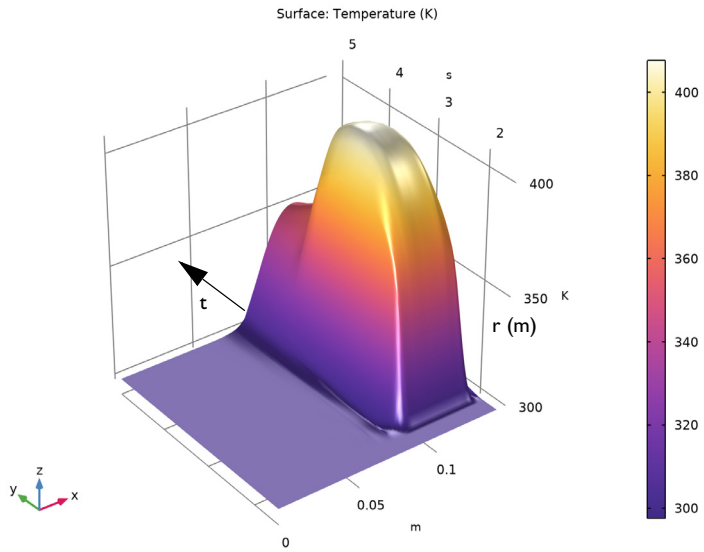

Figure 6: Temperature profile along the line indicated in Figure 5 at the disc surface ( $z = 0.013 \text{ m}$ ) as a function of time.



To investigate how much of the generated heat is dissipated to the air, study the surface integrals of the produced heat and the dissipated heat. These integrals give the total heat rate ( $W$ ) for heat production,  $Q_{\text{prod}}$ , and heat dissipation,  $Q_{\text{diss}}$ , as functions of time for the brake disc. The time integrals of these two quantities,  $W_{\text{prod}}$  and  $W_{\text{diss}}$ , give the total heat ( $J$ ) produced and dissipated, respectively, in the brake disc. Figure 7 shows a plot of the total produced heat and dissipated heat versus time. Eight seconds after the driver has stopped braking, a mere fraction of the produced heat has been dissipated. In other words, in order to cool down the system sufficiently the brake needs to remain disengaged for a much longer period than these eight seconds (100 seconds, in fact).

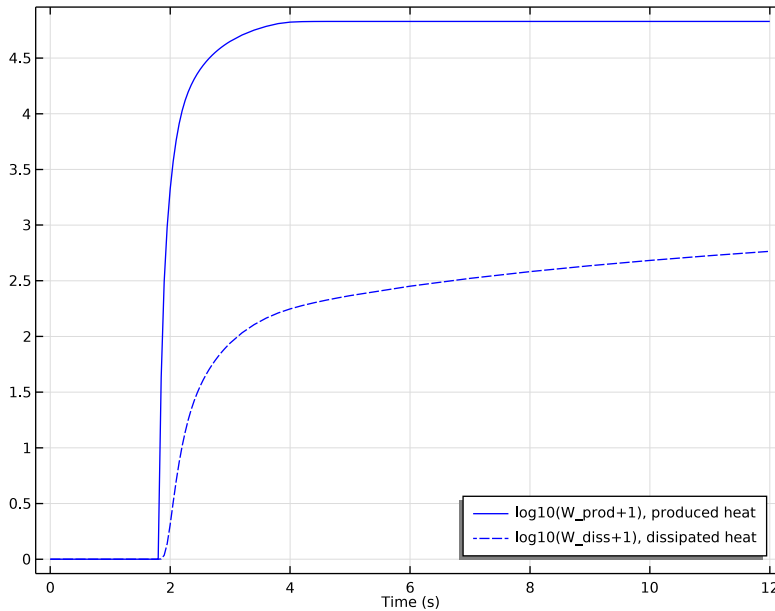

Figure 7: Comparison of total produced heat (solid line) and dissipated heat (dashed).

The results of this application can help engineers investigate how much abuse, in terms of specific braking sequences, a certain brake-disc design can tolerate before overheating. It is also possible to modify the parameters affecting the heat dissipation and investigate their influence.

### Reference

---

1. J.M. Coulson and J.F. Richardson, *Chemical Engineering*, vol. 1, eq. 9.88; material properties from appendix A2.

---

**Application Library path:** Heat\_Transfer\_Module/  
Thermal\_Contact\_and\_Friction/brake\_disc

---

### *Modeling Instructions*



---

From the **File** menu, choose **New**.

#### **NEW**

In the **New** window, click  **Model Wizard**.

#### **MODEL WIZARD**

- 1 In the **Model Wizard** window, click  **3D**.
- 2 In the **Select Physics** tree, select **Heat Transfer>Heat Transfer in Solids (ht)**.
- 3 Click **Add**.
- 4 Click  **Study**.
- 5 In the **Select Study** tree, select **General Studies>Time Dependent**.
- 6 Click  **Done**.

#### **GEOMETRY I**

Define the global parameters by loading the corresponding text file provided.

#### **GLOBAL DEFINITIONS**

##### *Parameters I*

- 1 In the **Model Builder** window, under **Global Definitions** click **Parameters I**.
- 2 In the **Settings** window for **Parameters**, locate the **Parameters** section.
- 3 Click  **Load from File**.
- 4 Browse to the model's Application Libraries folder and double-click the file `brake_disc_parameters.txt`.



#### **GEOMETRY I**

##### *Cylinder I (cyl1)*



- 1 In the **Geometry** toolbar, click  **Cylinder**.
- 2 In the **Settings** window for **Cylinder**, locate the **Size and Shape** section.

- 3 In the **Radius** text field, type 0.14.
- 4 In the **Height** text field, type 0.013.
- 5 In the **Geometry** toolbar, click  **Build All**.

#### *Cylinder 2 (cyl2)*

- 1 In the **Geometry** toolbar, click  **Cylinder**.
- 2 In the **Settings** window for **Cylinder**, locate the **Size and Shape** section.
- 3 In the **Radius** text field, type 0.08.
- 4 In the **Height** text field, type 0.01.
- 5 Locate the **Position** section. In the **z** text field, type 0.013.
- 6 In the **Geometry** toolbar, click  **Build All**.

#### *Work Plane 1 (wp1)*

- 1 In the **Geometry** toolbar, click  **Work Plane**.
- 2 In the **Settings** window for **Work Plane**, locate the **Plane Definition** section.
- 3 In the **z-coordinate** text field, type 0.013.
- 4 Click  **Show Work Plane**.

#### *Work Plane 1 (wp1)>Cubic Bézier 1 (cb1)*

- 1 In the **Work Plane** toolbar, click  **More Primitives** and choose **Cubic Bézier**.
- 2 In the **Settings** window for **Cubic Bézier**, locate the **Control Points** section.
- 3 In row **1**, set **yw** to 0.135.
- 4 In row **2**, set **xw** to 0.02, and **yw** to 0.135.
- 5 In row **3**, set **xw** to 0.05, and **yw** to 0.13.
- 6 In row **4**, set **xw** to 0.04, and **yw** to 0.105.
- 7 Locate the **Weights** section. In the **3** text field, type 2.5.

#### *Work Plane 1 (wp1)>Cubic Bézier 2 (cb2)*



- 1 In the **Work Plane** toolbar, click  **More Primitives** and choose **Cubic Bézier**.
- 2 In the **Settings** window for **Cubic Bézier**, locate the **Control Points** section.
- 3 In row **1**, set **xw** to 0.04.
- 4 In row **1**, set **yw** to 0.105, and **yw** to 0.03., and **yw** to 0.08.
- 5 In row **3**, set **xw** to 0.035, and **yw** to 0.09., and **yw** to 0.09.

#### *Work Plane 1 (wp1)>Cubic Bézier 3 (cb3)*



- 1 In the **Work Plane** toolbar, click  **More Primitives** and choose **Cubic Bézier**.

- 2 In the **Settings** window for **Cubic Bézier**, locate the **Control Points** section.
- 3 In row **1**, set **yw** to 0.09.
- 4 In row **2**, set **xw** to -0.035, and **yw** to 0.09.
- 5 In row **3**, set **xw** to -0.03, and **yw** to 0.08.
- 6 In row **4**, set **xw** to -0.04, and **yw** to 0.105.

*Work Plane 1 (wp1)>Cubic Bézier 4 (cb4)*

- 1 In the **Work Plane** toolbar, click  **More Primitives** and choose **Cubic Bézier**.
- 2 In the **Settings** window for **Cubic Bézier**, locate the **Control Points** section.
- 3 In row **1**, set **xw** to -0.04.
- 4 In row **2**, set **xw** to -0.05, and **yw** to 0.09., and **yw** to 0.13.
- 5 In row **3**, set **xw** to -0.02, and **yw** to 0.135.
- 6 In row **4**, set **yw** to 0.135.
- 7 Locate the **Weights** section. In the **2** text field, type 2.5.
- 8 In the **Work Plane** toolbar, click  **Build All**.

*Work Plane 1 (wp1)>Convert to Solid 1 (csol1)*

- 1 In the **Work Plane** toolbar, click  **Conversions** and choose **Convert to Solid**.
- 2 Click in the **Graphics** window and then press Ctrl+A to select all objects.
- 3 In the **Work Plane** toolbar, click  **Build All**.

*Extrude 1 (ext1)*

- 1 In the **Model Builder** window, under **Component 1 (comp1)>Geometry 1** right-click **Work Plane 1 (wp1)** and choose **Extrude**.
- 2 In the **Settings** window for **Extrude**, locate the **Distances** section.
- 3 In the table, enter the following settings:

<b>Distances (m)</b>
0.0065

- In the **Geometry** toolbar, click  **Build All**.  
The model geometry is now complete.

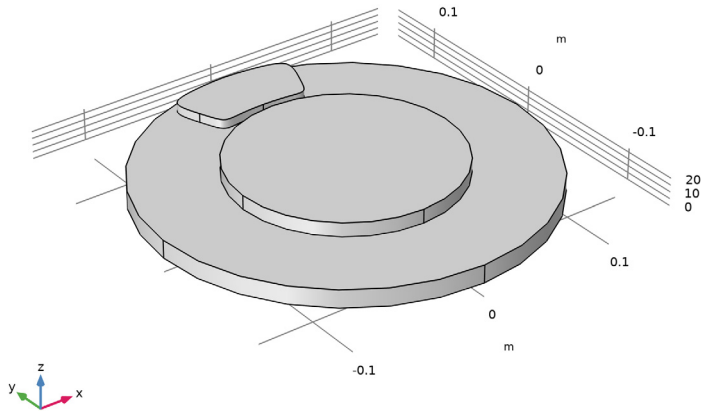

Next, define some selections of certain boundaries. You will use them when defining the settings for component couplings, boundary conditions, and so on.

## DEFINITIONS

### *Disc Faces*



- In the **Definitions** toolbar, click  **Explicit**.
- In the **Settings** window for **Explicit**, type **Disc Faces** in the **Label** text field.
- Locate the **Input Entities** section. From the **Geometric entity level** list, choose **Boundary**.
- Select Boundaries 1, 2, 4–6, 8, 13–15, and 18 only.

### *Pad Faces*

- In the **Definitions** toolbar, click  **Explicit**.
- In the **Settings** window for **Explicit**, type **Pad Faces** in the **Label** text field.
- Locate the **Input Entities** section. From the **Geometric entity level** list, choose **Boundary**.
- Select Boundaries 9, 10, 12, 16, and 17 only.

### *Contact Faces*

- In the **Definitions** toolbar, click  **Explicit**.

- 2 In the **Settings** window for **Explicit**, type Contact Faces in the **Label** text field.
- 3 Locate the **Input Entities** section. From the **Geometric entity level** list, choose **Boundary**.  
To select the contact surface boundary, it is convenient to temporarily switch to wireframe rendering.
- 4 Click the  **Wireframe Rendering** button in the **Graphics** toolbar.
- 5 Select Boundary 11 only.
- 6 Click the  **Wireframe Rendering** button in the **Graphics** toolbar again to return to the original state.

#### *External Surfaces*

- 1 In the **Definitions** toolbar, click  **Explicit**.
- 2 In the **Settings** window for **Explicit**, type External Surfaces in the **Label** text field.
- 3 Locate the **Input Entities** section. Select the **All domains** check box.
- 4 Locate the **Output Entities** section. From the **Output entities** list, choose **Adjacent boundaries**.

These instructions make you select the external boundaries of the wheel and the pad.

#### *Integration 1 (intop1)*

- 1 In the **Definitions** toolbar, click  **Nonlocal Couplings** and choose **Integration**.
- 2 In the **Settings** window for **Integration**, locate the **Source Selection** section.
- 3 From the **Geometric entity level** list, choose **Boundary**.
- 4 From the **Selection** list, choose **Contact Faces**.

#### *Integration 2 (intop2)*

- 1 In the **Definitions** toolbar, click  **Nonlocal Couplings** and choose **Integration**.
- 2 In the **Settings** window for **Integration**, locate the **Source Selection** section.
- 3 From the **Geometric entity level** list, choose **Boundary**.
- 4 From the **Selection** list, choose **External Surfaces**.

Now, define the velocity and acceleration of the car through these two piecewise and analytic functions.

#### *Piecewise 1 (pw1)*

- 1 In the **Definitions** toolbar, click  **Piecewise**.
- 2 In the **Settings** window for **Piecewise**, type v in the **Function name** text field.
- 3 Locate the **Definition** section. In the **Argument** text field, type t.
- 4 From the **Smoothing** list, choose **Continuous second derivative**.

5 From the **Transition zone** list, choose **Absolute size**.

6 In the **Size of transition zone** text field, type 0.2.

The function definition expects nondimensional quantities for the interval bounds, and the function values. The function definition below uses unit conversions to do so.

7 Find the **Intervals** subsection. In the table, enter the following settings:

Start	End	Function
0	$t\_brake\_start[1/s]$	$v0[s/m]$
$t\_brake\_start[1/s]$	$t\_brake\_end[1/s]$	$v0[s/m]+a0*(t[s]-t\_brake\_start)[s/m]$
$t\_brake\_end[1/s]$	12	$v0[s/m]+a0*(t\_brake\_end-t\_brake\_start)[s/m]$

8 Locate the **Units** section. In the **Arguments** text field, type s.

9 In the **Function** text field, type m/s.

10 Click  **Plot**.

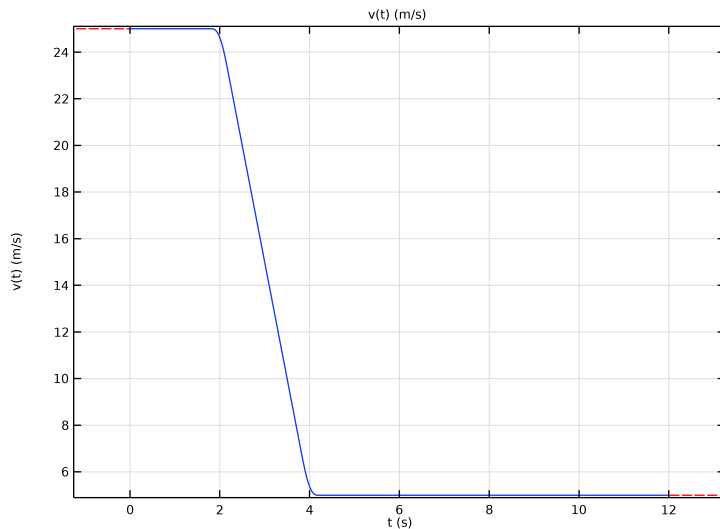

*Analytic 1 (an1)*

1 In the **Definitions** toolbar, click  **Analytic**.

2 In the **Settings** window for **Analytic**, type a in the **Function name** text field.

3 Locate the **Definition** section. In the **Expression** text field, type  $d(v(t), t)$ .

4 In the **Arguments** text field, type t.

5 Locate the **Units** section. In the table, enter the following settings:

Argument	Unit
t	s

6 In the **Function** text field, type  $m/s^2$ .

7 Locate the **Plot Parameters** section. In the table, enter the following settings:

Argument	Lower limit	Upper limit	Unit
t	0	10	s

8 Click  **Plot**.

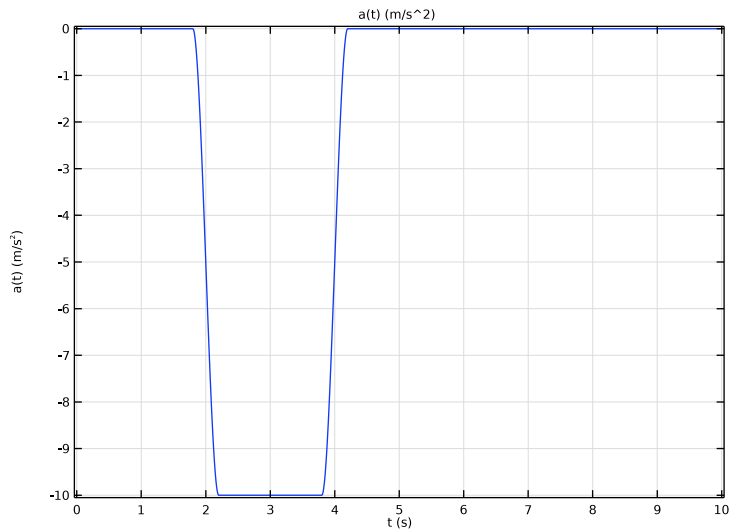

## MATERIALS

*Disc*

1 In the **Materials** toolbar, click  **Blank Material**.

2 In the **Settings** window for **Material**, type *Disc* in the **Label** text field.



3 Locate the **Material Contents** section. In the table, enter the following settings:

Property	Variable	Value	Unit	Property group
Thermal conductivity	$k_{iso}$ ; $k_{ii} = k_{iso}$ , $k_{ij} = 0$	82	W/(m·K)	Basic
Density	$\rho$	7870	kg/m <sup>3</sup>	Basic
Heat capacity at constant pressure	$C_p$	449	J/(kg·K)	Basic

*Pad*

1 In the **Materials** toolbar, click  **Blank Material**.

2 In the **Settings** window for **Material**, type Pad in the **Label** text field.

3 Select Domain 3 only.

4 Locate the **Material Contents** section. In the table, enter the following settings:

Property	Variable	Value	Unit	Property group
Thermal conductivity	$k_{iso}$ ; $k_{ii} = k_{iso}$ , $k_{ij} = 0$	8.7	W/(m·K)	Basic
Density	$\rho$	2000	kg/m <sup>3</sup>	Basic
Heat capacity at constant pressure	$C_p$	935	J/(kg·K)	Basic

## HEAT TRANSFER IN SOLIDS (HT)

*Solid 1*

In the **Model Builder** window, under **Component 1 (comp 1)>Heat Transfer in Solids (ht)** click **Solid 1**.

*Translational Motion 1*

1 In the **Physics** toolbar, click  **Attributes** and choose **Translational Motion**.

2 Select Domains 1 and 2 only.

3 In the **Settings** window for **Translational Motion**, locate the **Translational Motion** section.

4 Specify the  $\mathbf{u}_{trans}$  vector as

$-y*v(t)/r_{wheel}$	x
$x*v(t)/r_{wheel}$	y
0	z

### *Heat Flux 1*

- 1 In the **Physics** toolbar, click  **Boundaries** and choose **Heat Flux**.
- 2 In the **Settings** window for **Heat Flux**, locate the **Boundary Selection** section.
- 3 From the **Selection** list, choose **All boundaries**.
- 4 Locate the **Heat Flux** section. From the **Flux type** list, choose **Convective heat flux**.
- 5 From the **Heat transfer coefficient** list, choose **External forced convection**.
- 6 In the  $L$  text field, type 0.14.
- 7 In the  $U$  text field, type  $v(t)$ .
- 8 In the  $T_{\text{ext}}$  text field, type  $T_{\text{air}}$ .

### *Thermal Contact 1*

- 1 In the **Physics** toolbar, click  **Boundaries** and choose **Thermal Contact**.
- 2 Select Boundary 11 only.
- 3 In the **Settings** window for **Thermal Contact**, locate the **Contact Surface Properties** section.
- 4 In the  $p$  text field, type  $h_t \cdot t_{c1} \cdot Q_b / (\mu \cdot v(t))$ .
- 5 In the  $H_c$  text field, type 800[MPa].
- 6 Locate the **Thermal Friction** section. Click the **Heat rate** button.
- 7 In the  $P_b$  text field, type  $-m_{\text{car}} \cdot v(t) \cdot a(t) / 8$ .

### *Initial Values 1*

- 1 In the **Model Builder** window, click **Initial Values 1**.
- 2 In the **Settings** window for **Initial Values**, locate the **Initial Values** section.
- 3 In the  $T$  text field, type  $T_{\text{air}}$ .

### *Surface-to-Ambient Radiation 1*



- 1 In the **Physics** toolbar, click  **Boundaries** and choose **Surface-to-Ambient Radiation**.
- 2 In the **Settings** window for **Surface-to-Ambient Radiation**, locate the **Boundary Selection** section.
- 3 From the **Selection** list, choose **Disc Faces**.
- 4 Locate the **Surface-to-Ambient Radiation** section. From the  $\epsilon$  list, choose **User defined**. In the associated text field, type 0.28.
- 5 In the  $T_{\text{amb}}$  text field, type  $T_{\text{air}}$ .

### *Surface-to-Ambient Radiation 2*





- 1 In the **Physics** toolbar, click  **Boundaries** and choose **Surface-to-Ambient Radiation**.

- 2 In the **Settings** window for **Surface-to-Ambient Radiation**, locate the **Boundary Selection** section.
- 3 From the **Selection** list, choose **Pad Faces**.
- 4 Locate the **Surface-to-Ambient Radiation** section. From the  $\epsilon$  list, choose **User defined**. In the associated text field, type 0.8.
- 5 In the  $T_{amb}$  text field, type  $T_{air}$ .

#### *Symmetry I*

- 1 In the **Physics** toolbar, click  **Boundaries** and choose **Symmetry**.
- 2 Select Boundary 3 only.  
To compute the produced and dissipated heats, integrate the corresponding heat rate variables,  $Q_{prod}$  and  $Q_{diss}$ , over time. For this purpose, define two ODEs using a **Global Equations** node.
- 3 Click the  **Show More Options** button in the **Model Builder** toolbar.
- 4 In the **Show More Options** dialog box, in the tree, select the check box for the node **Physics>Equation-Based Contributions**.
- 5 Click **OK**.

#### *Global Equations I*

- 1 In the **Physics** toolbar, click  **Global** and choose **Global Equations**.
- 2 In the **Settings** window for **Global Equations**, locate the **Units** section.
- 3 Click  **Select Dependent Variable Quantity**.
- 4 In the **Physical Quantity** dialog box, type energy in the text field.
- 5 Click  **Filter**.
- 6 In the tree, select **General>Energy (J)**.
- 7 Click **OK**.
- 8 In the **Settings** window for **Global Equations**, locate the **Units** section.
- 9 Click  **Select Source Term Quantity**.
- 10 In the **Physical Quantity** dialog box, type power in the text field.
- 11 Click  **Filter**.
- 12 In the tree, select **General>Power (W)**.
- 13 Click **OK**.
- 14 In the **Settings** window for **Global Equations**, locate the **Global Equations** section.



15 In the table, enter the following settings:

Name	$f(u,ut,utt,t)$ (W)	Initial value (u_0) (J)	Initial value (u_t0) (W)	Description
W_prod	W_prodt-intop1(ht.tc1.Qb)	0	0	Produced heat
W_diss	W_disst+(intop2(ht.q0+ht.rflux))	0	0	Dissipated heat

Here,  $W\_prodt$  (resp.  $W\_disst$ ) is COMSOL Multiphysics syntax for the time derivative of  $W\_prod$  (resp.  $W\_diss$ ). The quantities  $intop1(ht.tc1.Qb)$  and  $intop2(ht.q0+ht.rflux)$  correspond to  $Q\_prod$  and  $Q\_diss$ . The table thus defines the first-order ODEs corresponding to Equation 1, so that  $W\_prod$  and  $W\_diss$  host the produced and dissipated heats. The initial values follow from setting  $t = 0$ .

## MESH 1

### Free Triangular 1

- 1 In the **Mesh** toolbar, click  **Boundary** and choose **Free Triangular**.
- 2 Click the  **Transparency** button in the **Graphics** toolbar.
- 3 Select Boundaries 4, 7, and 11 only.
- 4 Click the  **Transparency** button in the **Graphics** toolbar again to return to the original state.

### Size

- 1 In the **Model Builder** window, click **Size**.
- 2 In the **Settings** window for **Size**, locate the **Element Size** section.
- 3 From the **Predefined** list, choose **Extra fine**.

### Swept 1

In the **Mesh** toolbar, click  **Swept**.

### Distribution 1

- 1 Right-click **Swept 1** and choose **Distribution**.
- 2 In the **Settings** window for **Distribution**, locate the **Distribution** section.
- 3 In the **Number of elements** text field, type 2.

- 4 In the **Model Builder** window, right-click **Mesh 1** and choose **Build All**.  
The complete mesh consists of roughly 5800 elements.

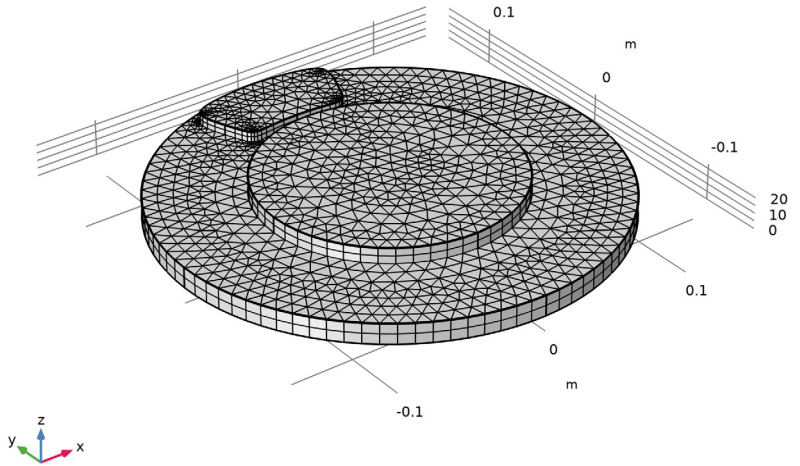

## STUDY 1

### Step 1: Time Dependent

- 1 In the **Model Builder** window, under **Study 1** click **Step 1: Time Dependent**.
- 2 In the **Settings** window for **Time Dependent**, locate the **Study Settings** section.
- 3 In the **Output times** text field, type `range(0,0.5,1.5) range(1.55,0.05,3) range(3.2,0.2,5) range(6,1,12)`.

### Solution 1 (sol1)

- 1 In the **Study** toolbar, click  **Show Default Solver**.
- 2 In the **Model Builder** window, expand the **Solution 1 (sol1)** node, then click **Time-Dependent Solver 1**.
- 3 In the **Settings** window for **Time-Dependent Solver**, click to expand the **Time Stepping** section.
- 4 From the **Steps taken by solver** list, choose **Intermediate**.

This setting forces the solver to take at least one step in each specified interval.

5 In the **Study** toolbar, click  **Compute**.

## RESULTS

The first of the two default plots displays the surface temperature of the brake disc and pad at the end of the simulation interval. Modify this plot to show the time step just before releasing the brake.

### *Temperature (ht)*

- 1 In the **Model Builder** window, under **Results** click **Temperature (ht)**.
- 2 In the **Settings** window for **3D Plot Group**, locate the **Data** section.
- 3 From the **Time (s)** list, choose **3.8**.

### *Surface 2*

- 1 In the **Model Builder** window, expand the **Temperature (ht)** node, then click **Surface 2**.
- 2 In the **Settings** window for **Surface**, click to expand the **Title** section.
- 3 From the **Title type** list, choose **None**.

### *Surface 3*

- 1 In the **Model Builder** window, click **Surface 3**.
- 2 In the **Settings** window for **Surface**, locate the **Title** section.
- 3 From the **Title type** list, choose **None**.
- 4 In the **Temperature (ht)** toolbar, click  **Plot**.

Compare the result to the plot shown in [Figure 4](#).

To compare the total produced heat and the dissipated heat, as done in [Figure 7](#), follow the steps given below.

### *Dissipated and Produced Heats*

- 1 In the **Home** toolbar, click  **Add Plot Group** and choose **ID Plot Group**.
- 2 In the **Settings** window for **ID Plot Group**, type Dissipated and Produced Heats in the **Label** text field.
- 3 Click to expand the **Title** section. From the **Title type** list, choose **None**.
- 4 Click to collapse the **Title** section. Locate the **Plot Settings** section. Select the **x-axis label** check box.
- 5 In the associated text field, type Time (s).
- 6 Locate the **Legend** section. From the **Position** list, choose **Lower right**.

### Point Graph 1

- 1 In the **Dissipated and Produced Heats** toolbar, click  **Point Graph**.
- 2 Select Point 1 only.
- 3 In the **Settings** window for **Point Graph**, locate the **y-Axis Data** section.
- 4 In the **Expression** text field, type  $\log_{10}(W_{\text{prod}}+1)$ .
- 5 Click to expand the **Coloring and Style** section. From the **Color** list, choose **Blue**.
- 6 Click to expand the **Legends** section. Select the **Show legends** check box.
- 7 From the **Legends** list, choose **Manual**.
- 8 In the table, enter the following settings:

---

<b>Legends</b>
$\log_{10}(W_{\text{prod}}+1)$ , produced heat

---

### Point Graph 2

- 1 Right-click **Point Graph 1** and choose **Duplicate**.
- 2 In the **Settings** window for **Point Graph**, locate the **y-Axis Data** section.
- 3 In the **Expression** text field, type  $\log_{10}(W_{\text{diss}}+1)$ .
- 4 Locate the **Coloring and Style** section. Find the **Line style** subsection. From the **Line** list, choose **Dashed**.
- 5 Locate the **Legends** section. In the table, enter the following settings:

---

<b>Legends</b>
$\log_{10}(W_{\text{diss}}+1)$ , dissipated heat

---

### Dissipated and Produced Heats

Finally, follow the steps below to reproduce the plot in [Figure 6](#).

### Cut Line 3D 1

- 1 In the **Results** toolbar, click  **Cut Line 3D**.
- 2 In the **Settings** window for **Cut Line 3D**, locate the **Line Data** section.
- 3 In row **Point 1**, set **Z** to 0.013.
- 4 In row **Point 2**, set **X** to -0.047, **y** to 0.1316, and **z** to 0.013.

5 Click  **Plot**.

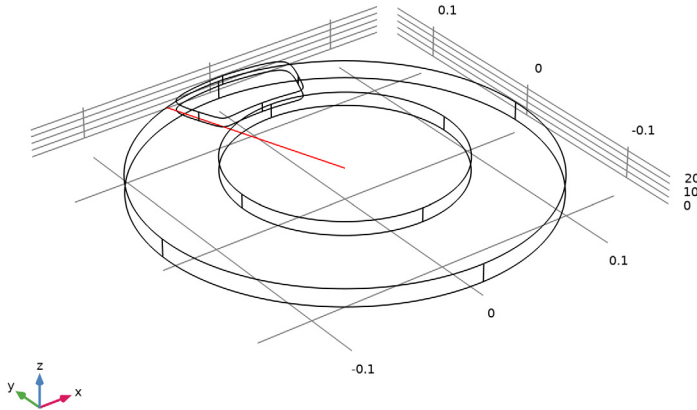

#### *Parametric Extrusion ID 1*

- 1 In the **Results** toolbar, click  **More Datasets** and choose **Parametric Extrusion ID**.
- 2 In the **Settings** window for **Parametric Extrusion ID**, locate the **Data** section.
- 3 From the **Time selection** list, choose **From list**.
- 4 Click and shift-click in the list to select all time steps from 1.5 s through 5 s.



#### *Temperature Profile vs. Time*

- 1 In the **Results** toolbar, click  **2D Plot Group**.
- 2 In the **Settings** window for **2D Plot Group**, type **Temperature Profile vs. Time** in the **Label** text field.

#### *Surface 1*

- 1 In the **Temperature Profile vs. Time** toolbar, click  **Surface**.
- 2 In the **Settings** window for **Surface**, locate the **Coloring and Style** section.
- 3 From the **Color table** list, choose **HeatCameraLight**.

#### *Height Expression 1*

- 1 In the **Temperature Profile vs. Time** toolbar, click  **Height Expression**.
- 2 Click  **Plot**.



In order to visualize the temperature on each side of the thermal contact, follow the next steps.

#### *Temperature (ht) 1*

In the **Model Builder** window, right-click **Temperature (ht)** and choose **Duplicate**.

#### *Surface 2*

- 1 In the **Model Builder** window, expand the **Results>Temperature (ht)** node.
- 2 Right-click **Results>Temperature (ht)>Surface 2** and choose **Delete**.

#### *Surface 3*

In the **Model Builder** window, right-click **Surface 3** and choose **Delete**.

#### *Surface 2*

- 1 In the **Model Builder** window, expand the **Results>Temperature (ht) 1** node, then click **Surface 2**.
- 2 In the **Settings** window for **Surface**, click to expand the **Inherit Style** section.
- 3 From the **Plot** list, choose **None**.

#### *Surface 1*

In the **Model Builder** window, under **Results>Temperature (ht) 1** right-click **Surface 1** and choose **Delete**.

#### *Contact temperatures (ht)*

- 1 In the **Model Builder** window, under **Results** click **Temperature (ht) 1**.
- 2 In the **Settings** window for **3D Plot Group**, type **Contact temperatures (ht)** in the **Label** text field.

#### *Upside*

- 1 In the **Model Builder** window, under **Results>Contact temperatures (ht)** click **Surface 2**.
- 2 In the **Settings** window for **Surface**, type **Upside** in the **Label** text field.
- 3 Locate the **Expression** section. Select the **Description** check box.
- 4 In the associated text field, type **Upside temperature**.
- 5 Locate the **Coloring and Style** section. From the **Color table** list, choose **HeatCameraLight**.

#### *Downside*

- 1 In the **Model Builder** window, under **Results>Contact temperatures (ht)** click **Surface 3**.
- 2 In the **Settings** window for **Surface**, type **Downside** in the **Label** text field.
- 3 Locate the **Expression** section. Select the **Description** check box.

4 In the associated text field, type `Downside temperature`.

*Deformation*

1 In the **Model Builder** window, expand the **Upside** node, then click **Deformation**.

2 In the **Settings** window for **Deformation**, locate the **Scale** section.

3 In the **Scale factor** text field, type 10.

4 In the **Contact temperatures (ht)** toolbar, click  **Plot**.