



# Current Density Distribution in a Solid Oxide Fuel Cell

## Introduction

This example studies the current density distribution in a solid oxide fuel cell (SOFC). It includes the full coupling between the mass balances at the anode and cathode, the momentum balances in the gas channels, the gas flow in the porous electrodes, the balance of the ionic current carried by the oxide ion, and an electronic current balance.

## Model Definition

An SOFC is constructed with two porous gas diffusion electrodes (GDEs) with an electrolyte sandwiched in the middle; see [Figure 1](#).

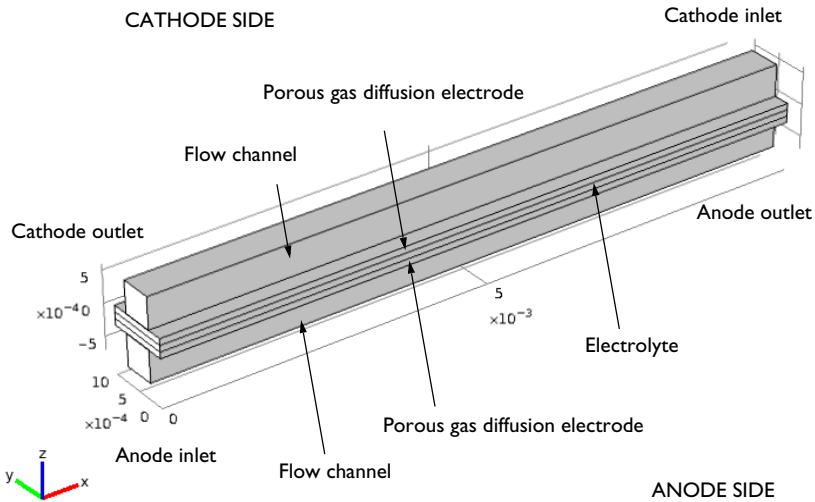
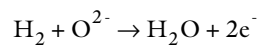

Figure 1: Geometry of the unit cell, with anode at the bottom and cathode at the top.

The fuel feed in the cathode and anode is counterflow, with hydrogen-rich anode gas entering from the left.

The electrochemical reactions in the cell are given below.

- Anode



- Cathode:

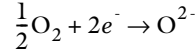

The model includes the following processes:

- Electronic charge balance (Ohm's law)
- Ionic charge balance (Ohm's law)
- Butler-Volmer charge transfer kinetics
- Mass balances in gas phase in both gas channels and GDEs (Maxwell-Stefan Diffusion and Convection)
- Flow distribution in gas channels (Navier-Stokes equations)
- Flow in the porous GDEs (Brinkman equations)

### CHARGE BALANCES

The electronic and ionic charge balance in the anode and cathode current feeders, the electrolyte and GDEs are solved for using a Hydrogen Fuel Cell interface.

Assume that Butler-Volmer charge transfer kinetics describe the charge transfer current density. At the anode, hydrogen is oxidized to form water, and assuming the first electron transfer to be the rate determining step, the following charge transfer kinetics equation applies:

$$i_{a,ct} = i_{0,a} \left( \frac{p_{\text{h}_2}}{p_{\text{h}_2,\text{ref}}} \exp\left(\frac{0.5F}{RT} \eta\right) - \frac{p_{\text{h}_2\text{o}}}{p_{\text{h}_2\text{o},\text{ref}}} \exp\left(\frac{-1.5F}{RT} \eta\right) \right)$$

Here  $i_{0,a}$  is the anode exchange current density (SI unit: A/m<sup>2</sup>),  $p_{\text{h}_2}$  is the partial pressure of hydrogen,  $p_{\text{h}_2\text{o}}$  is the partial pressure of water,  $p_{\text{h}_2,\text{ref}}$  and  $p_{\text{h}_2\text{o},\text{ref}}$  is the reference pressures (SI unit: Pa). Furthermore,  $F$  is Faraday's constant (SI unit: C/mol),  $R$  the gas constant (SI unit: J/(mol·K)),  $T$  the temperature (SI unit: K), and  $\eta$  the overvoltage (SI unit: V).

For the cathode, use the relation

$$i_{c,ct} = i_{0,c} \left[ \exp\left(\frac{3.5F}{RT} \eta\right) - \frac{p_{\text{o}_2}}{p_{\text{o}_2,\text{ref}}} \exp\left(\frac{-0.5F}{RT} \eta\right) \right]$$

where  $i_{0,c}$  is the cathode exchange current density (SI unit: A/m<sup>2</sup>), and  $p_{\text{o}_2}$  is the partial pressure of oxygen.

The overvoltage is defined as

$$\eta = \phi_{\text{electronic}} - \phi_{\text{ionic}} - \Delta\phi_{\text{eq}}$$

where  $\Delta\phi_{\text{eq}}$  is the equilibrium potential difference (SI unit: V).

At the anode's inlet boundary, the potential is fixed at a reference potential of zero. At the cathode's inlet boundary, set the potential to the cell voltage,  $V_{\text{cell}}$ . The latter is given by

$$V_{\text{cell}} = \Delta\phi_{\text{eq,c}} - \Delta\phi_{\text{eq,a}} - V_{\text{pol}}$$

where  $V_{\text{pol}}$  is the polarization. In this model, you simulate the fuel cell for a range of cell voltage (ranging from around 0.2 V to 0.95 V) by using  $V_{\text{pol}}$  in the range 0.05 V through 0.8 V as the parameter for the parametric solver.

For the ionic charge balance equations, apply insulating boundary conditions at all external boundaries. At the interior boundaries, continuity in current and potential applies by default.

### **MULTICOMPONENT MASS TRANSPORT**

SOFCS can be operated on many different fuels. This model describes a unit running on hydrogen and air. At the anode, a humidified hydrogen gas is supplied as fuel, meaning that the gas consists of two components: hydrogen and water vapor. In the cathode, humidified air is supplied, consisting of three components: oxygen, water vapor, and nitrogen.

The material transport is described by the Maxwell-Stefan's diffusion and convection equations, solved for by the Hydrogen Fuel Cell interface.

The boundary conditions at the walls of the gas channel and GDE are zero mass flux (insulating condition). At the inlet, the composition is specified, while the outlet condition is convective flux. This assumption means that the convective term dominates the transport perpendicular to this boundary.

Continuity in composition and flux apply for all mass balances at the interfaces between the GDEs and the channels.

### **GAS-FLOW EQUATIONS**

The Free and Porous Media Flow interface is used for solving for the velocity field and pressure. The compressible Navier-Stokes equations govern the flow in the open channels and the Brinkman equations describe the flow velocity in the porous GDEs.

At the inlet and outlet, you set the pressure, specifying a slight overpressure at the inlet to drive the flow (2 Pa at the anode, and 6 Pa at the cathode).

Couplings for the density, dynamic viscosity, velocity, pressure and net mass sources and sinks are made between the Hydrogen Fuel Cell and Free and Porous Media Flow interface by using Reacting Flow, H2 Gas Phase and Reacting Flow, O2 Gas Phase multiphysics nodes.

## Results and Discussion

Figure 2 shows the oxygen mole fraction in the cathode at a cell polarization of 0.8 V. The oxygen depletion is substantial, which has implications on the reaction distribution at the cathode.

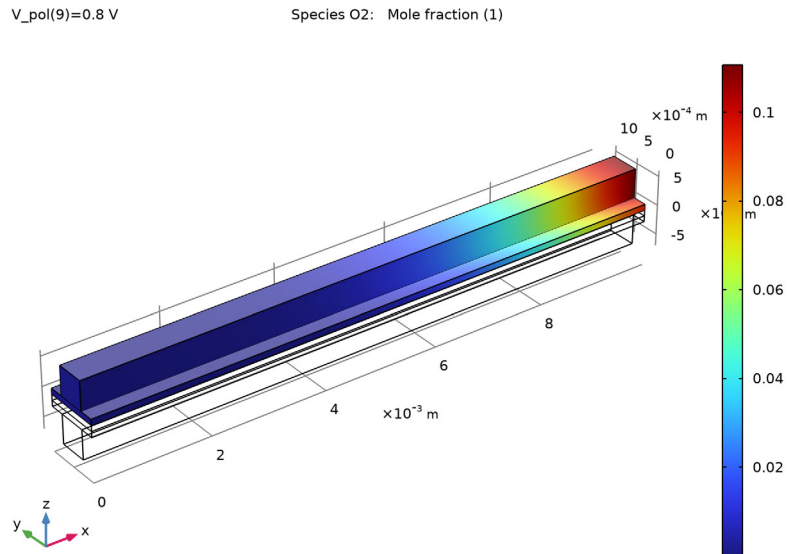
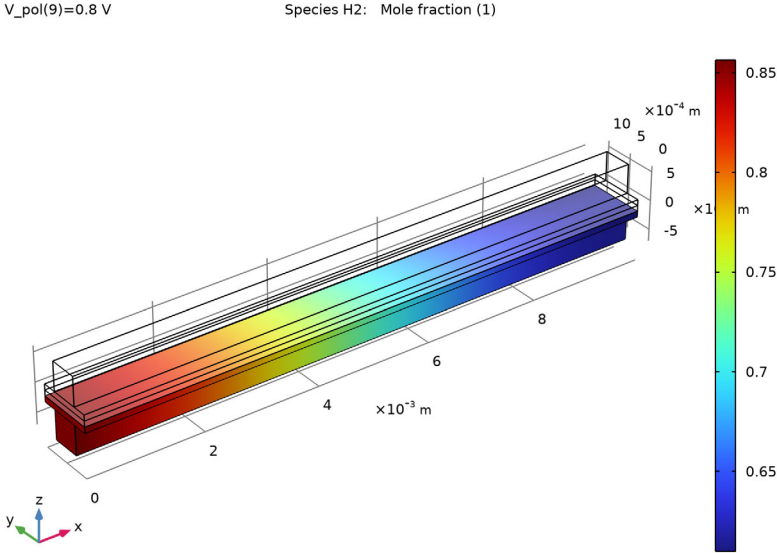

Figure 2: Oxygen mole fraction in the gas channel and in the gas diffusion cathode while operating at a cell voltage of 0.8 V.

The mole fraction of hydrogen in the anode also decreases along the channel. [Figure 3](#) below shows the distribution of hydrogen. It shows that the depletion is not as pronounced as for the cathode.



*Figure 3: Hydrogen distribution in the anode at 0.8 V cell voltage.*

A consequence of the concentration distribution is that the current density is nonuniform in the GDEs. [Figure 4](#) depicts the current density distribution at the cathode side of the ionic conductor.

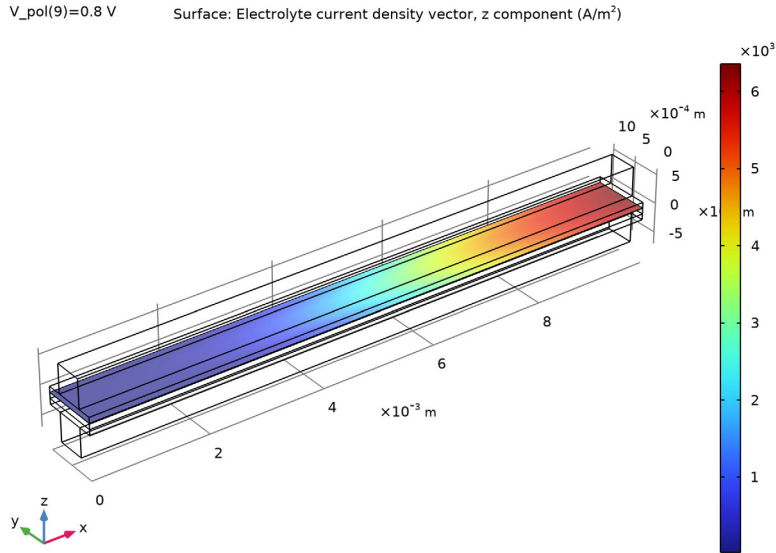

*Figure 4: The electrolyte current density in the unit cell operating at 0.8 V. The cathode inlet is to the right.*

As a consequence of oxygen depletion, the current density distribution is poor, with most of the current produced close to the cathode inlet. One way to improve the operating conditions is to increase the cathode flow rate, thus improving the oxygen mass transport.

Figure 5 shows the voltage as a function of the total current (polarization curve).

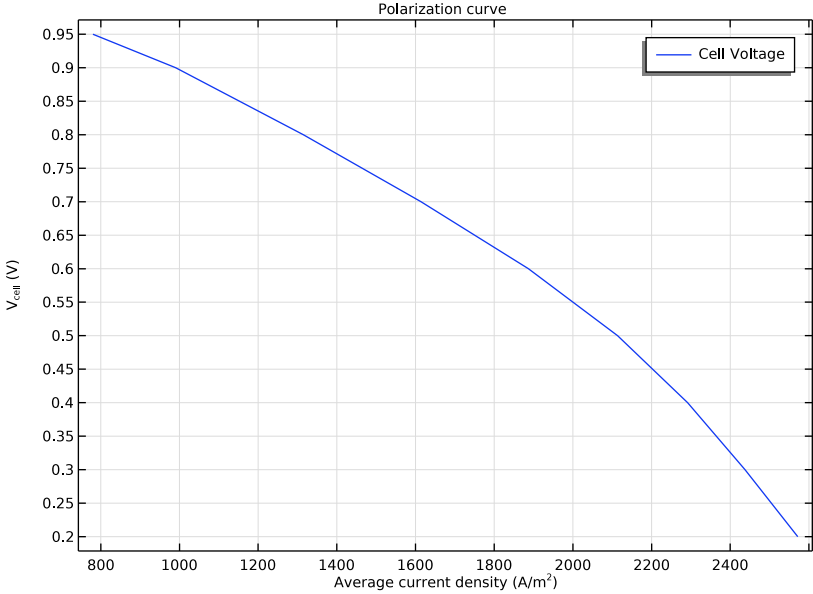

Figure 5: Polarization curve.



Figure 6 shows the power output as a function of the cell voltage. The model predicts a maximum power-output of about  $1100 \text{ W/m}^2$  for the unit cell.

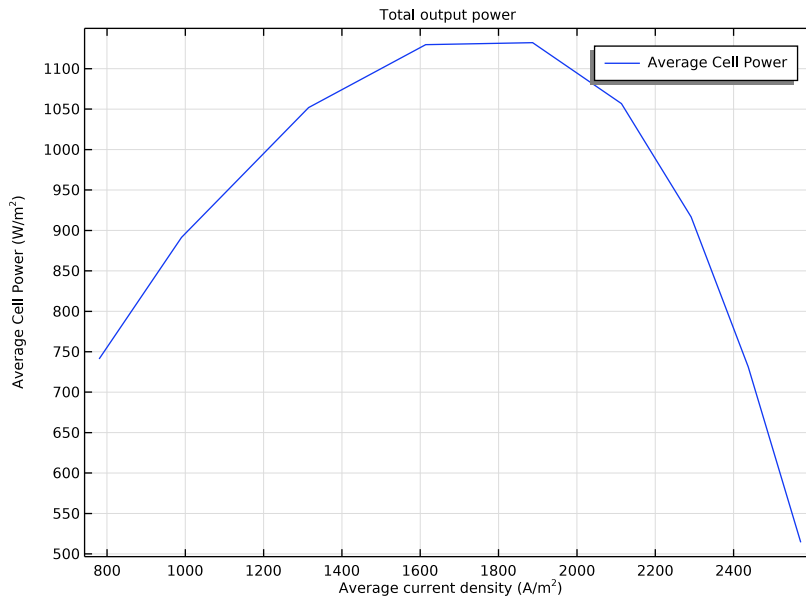

Figure 6: Power output as a function of cell voltage.

### References

1. J. Hartvigsen, S. Elangovan, and A. Khandkar, *Science and Technology of Zirconia V*, S.P.S. Badwal, M.J. Bannister, and R.H.J. Hannink, eds., p. 682, Technomic Publishing Company Inc., Lancaster, P.A., 1993.
2. R. Herbin, J.M. Fiard, and J.R. Ferguson, *First European Solid Oxide Fuel Cell Forum Proceedings*, U. Bossel, ed., p. 317, Lucerne, Switzerland, 1994.

**Application Library path:** Fuel\_Cell\_and\_Electrolyzer\_Module/Fuel\_Cells/  
sofc\_unit\_cell

## Modeling Instructions

---

From the **File** menu, choose **New**.

### NEW

In the **New** window, click  **Model Wizard**.

### MODEL WIZARD

- 1 In the **Model Wizard** window, click  **3D**.
- 2 In the **Select Physics** tree, select **Electrochemistry>Hydrogen Fuel Cells>Solid Oxide (fc)**.
- 3 Click **Add**.
- 4 In the **Select Physics** tree, select **Fluid Flow>Porous Media and Subsurface Flow>Free and Porous Media Flow (fp)**.
- 5 Click **Add**.
- 6 In the **Velocity field** text field, type  $u_c$ .
- 7 In the **Velocity field components** table, enter the following settings:

            
 $u_c$

            
 $v_c$



            
 $w_c$

- 8 In the **Pressure** text field, type  $p_c$ .
- 9 In the **Select Physics** tree, select **Fluid Flow>Porous Media and Subsurface Flow>Free and Porous Media Flow (fp)**.
- 10 Click **Add**.
- 11 In the **Velocity field** text field, type  $u_a$ .
- 12 In the **Velocity field components** table, enter the following settings:

            
 $u_a$

            
 $v_a$

            
 $w_a$

- 13 In the **Pressure** text field, type  $p_a$ .
- 14 Click  **Study**.
- 15 In the **Select Study** tree, select **Preset Studies for Selected Physics Interfaces>Hydrogen Fuel Cell>Stationary with Initialization**.
- 16 Click  **Done**.

## GLOBAL DEFINITIONS

Define the parameters using the text file provided.

*Parameters 1*

- 1 In the **Model Builder** window, under **Global Definitions** click **Parameters 1**.
- 2 In the **Settings** window for **Parameters**, locate the **Parameters** section.
- 3 Click  **Load from File**.
- 4 Browse to the model's Application Libraries folder and double-click the file `sofc_unit_cell_parameters.txt`.

## GEOMETRY 1



Create the geometry by first defining the 2D cross section of the device, then extrude it to create the 3D model geometry.

*Work Plane 1 (wp1)*



- 1 In the **Geometry** toolbar, click  **Work Plane**.
  - 2 In the **Settings** window for **Work Plane**, locate the **Plane Definition** section.
  - 3 From the **Plane** list, choose **yz-plane**.
- Add rectangles as described below.

- 4 Click  **Show Work Plane**.



*Work Plane 1 (wp1)>Rectangle 1 (r1)*

- 1 In the **Work Plane** toolbar, click  **Rectangle**.
- 2 In the **Settings** window for **Rectangle**, locate the **Size and Shape** section.
- 3 In the **Width** text field, type `W_channel+W_rib`.
- 4 In the **Height** text field, type `H_gde`.
- 5 Click  **Build Selected**.
- 6 Click the  **Zoom Extents** button in the **Graphics** toolbar.



*Work Plane 1 (wp1)>Rectangle 2 (r2)*

- 1 In the **Work Plane** toolbar, click  **Rectangle**.
- 2 In the **Settings** window for **Rectangle**, locate the **Size and Shape** section.
- 3 In the **Width** text field, type `W_channel+W_rib`.
- 4 In the **Height** text field, type `H_electrolyte`.
- 5 Locate the **Position** section. In the **yw** text field, type `-H_electrolyte`.
- 6 Click  **Build Selected**.



*Work Plane 1 (wp1)>Rectangle 3 (r3)*

- 1 In the **Work Plane** toolbar, click  **Rectangle**.
- 2 In the **Settings** window for **Rectangle**, locate the **Size and Shape** section.
- 3 In the **Width** text field, type  $W_{\text{channel}}+W_{\text{rib}}$ .
- 4 In the **Height** text field, type  $H_{\text{gde}}$ .
- 5 Locate the **Position** section. In the **yw** text field, type  $-H_{\text{electrolyte}}-H_{\text{gde}}$ .
- 6 Click  **Build Selected**.

*Work Plane 1 (wp1)>Rectangle 4 (r4)*

- 1 In the **Work Plane** toolbar, click  **Rectangle**.
- 2 In the **Settings** window for **Rectangle**, locate the **Size and Shape** section.
- 3 In the **Width** text field, type  $W_{\text{channel}}$ .
- 4 In the **Height** text field, type  $H_{\text{channel}}$ .
- 5 Locate the **Position** section. In the **xw** text field, type  $W_{\text{rib}}/2$ .
- 6 In the **yw** text field, type  $H_{\text{gde}}$ .
- 7 Click  **Build Selected**.

*Work Plane 1 (wp1)>Rectangle 5 (r5)*

- 1 In the **Work Plane** toolbar, click  **Rectangle**.
- 2 In the **Settings** window for **Rectangle**, locate the **Size and Shape** section.
- 3 In the **Width** text field, type  $W_{\text{channel}}$ .
- 4 In the **Height** text field, type  $H_{\text{channel}}$ .
- 5 Locate the **Position** section. In the **xw** text field, type  $W_{\text{rib}}/2$ .
- 6 In the **yw** text field, type  $-H_{\text{gde}}-H_{\text{electrolyte}}-H_{\text{channel}}$ .
- 7 Click  **Build Selected**.
- 8 Click the  **Zoom Extents** button in the **Graphics** toolbar.

*Extrude 1 (ext1)*

- 1 In the **Model Builder** window, under **Component 1 (comp1)>Geometry 1** right-click **Work Plane 1 (wp1)** and choose **Extrude**.
- 2 In the **Settings** window for **Extrude**, locate the **Distances** section.
- 3 In the table, enter the following settings:

---

**Distances (m)**

---

L

---

4 Click  **Build All Objects**.

5 Click the  **Zoom Extents** button in the **Graphics** toolbar.

The model geometry is now complete, and it should look like that in the figure below.

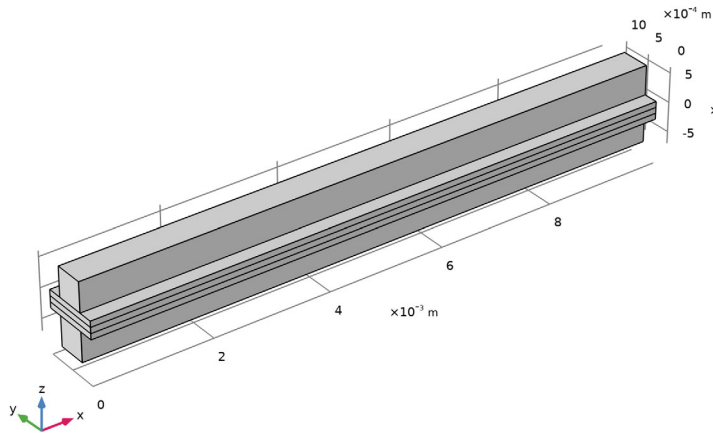

## DEFINITIONS

Now make a number of selections to facilitate choosing different parts of the geometry when setting up the model.

### *Anode Flow Channel*

- 1 In the **Definitions** toolbar, click  **Explicit**.
- 2 In the **Settings** window for **Explicit**, type Anode Flow Channel in the **Label** text field.
- 3 Select Domain 4 only.

### *Anode Gas Diffusion Electrode*

- 1 In the **Definitions** toolbar, click  **Explicit**.
- 2 In the **Settings** window for **Explicit**, type Anode Gas Diffusion Electrode in the **Label** text field.
- 3 Select Domain 1 only.

### *Cathode Gas Diffusion Electrode*

- 1 In the **Definitions** toolbar, click  **Explicit**.

2 In the **Settings** window for **Explicit**, type Cathode Gas Diffusion Electrode in the **Label** text field.

3 Select Domain 3 only.

#### *Cathode Flow Channel*

1 In the **Definitions** toolbar, click  **Explicit**.

2 In the **Settings** window for **Explicit**, type Cathode Flow Channel in the **Label** text field.

3 Select Domain 5 only.

#### *Membrane*

1 In the **Definitions** toolbar, click  **Explicit**.

2 In the **Settings** window for **Explicit**, type Membrane in the **Label** text field.

3 Select Domain 2 only.

### **FREE AND POROUS MEDIA FLOW - CATHODE**

Set up the domains applicable for the flow interfaces.

1 In the **Model Builder** window, under **Component 1 (comp1)** click **Free and Porous Media Flow (fp)**.

2 In the **Settings** window for **Free and Porous Media Flow**, type Free and Porous Media Flow - Cathode in the **Label** text field.

3 Locate the **Domain Selection** section. In the list, choose **1, 2,** and **4**.

4 Click  **Remove from Selection**.

5 Select Domains 3 and 5 only.

### **FREE AND POROUS MEDIA FLOW - ANODE**

1 In the **Model Builder** window, under **Component 1 (comp1)** click **Free and Porous Media Flow 2 (fp2)**.

2 In the **Settings** window for **Free and Porous Media Flow**, type Free and Porous Media Flow - Anode in the **Label** text field.

3 Locate the **Domain Selection** section. In the list, choose **2, 3,** and **5**.

4 Click  **Remove from Selection**.

5 Select Domains 1 and 4 only.

### **MULTIPHYSICS**

Next, couple the interfaces appropriately using the reacting flow multiphysics coupling nodes. Note that currently, the multiphysics nodes may not be applicable to any domain

selections, but the selections will be automatically updated when the **Hydrogen Fuel Cell** interface is set up.

#### *Reacting Flow, H2 Gas Phase 1 (rfh1)*

- 1 In the **Physics** toolbar, click  **Multiphysics Couplings** and choose **Domain>Reacting Flow, H2 Gas Phase**.
- 2 In the **Settings** window for **Reacting Flow, H2 Gas Phase**, locate the **Coupled Interfaces** section.
- 3 From the **Fluid flow** list, choose **Free and Porous Media Flow - Anode (fp2)**.

#### *Reacting Flow, O2 Gas Phase 1 (rfol)*

In the **Physics** toolbar, click  **Multiphysics Couplings** and choose **Domain>Reacting Flow, O2 Gas Phase**.

### **HYDROGEN FUEL CELL (FC)**

Set up the current distribution and mass transport model. The default gas species are hydrogen and water on the anode side, and oxygen and nitrogen on the cathode side. Additionally, include water on the cathode side.

- 1 In the **Model Builder** window, under **Component 1 (comp1)** click **Hydrogen Fuel Cell (fc)**.
- 2 In the **Settings** window for **Hydrogen Fuel Cell**, locate the **O2 Gas Mixture** section.
- 3 Select the **H2O** check box.

Add the relevant domain nodes.

#### *Membrane 1*

- 1 In the **Physics** toolbar, click  **Domains** and choose **Membrane**.
- 2 In the **Settings** window for **Membrane**, locate the **Domain Selection** section.
- 3 From the **Selection** list, choose **Membrane**.

#### *H2 Gas Diffusion Electrode 1*

- 1 In the **Physics** toolbar, click  **Domains** and choose **H2 Gas Diffusion Electrode**.
- 2 In the **Settings** window for **H2 Gas Diffusion Electrode**, locate the **Domain Selection** section.
- 3 From the **Selection** list, choose **Anode Gas Diffusion Electrode**.

#### *H2 Gas Flow Channel 1*

- 1 In the **Physics** toolbar, click  **Domains** and choose **H2 Gas Flow Channel**.
- 2 In the **Settings** window for **H2 Gas Flow Channel**, locate the **Domain Selection** section.

3 From the **Selection** list, choose **Anode Flow Channel**.

#### *O2 Gas Diffusion Electrode I*

1 In the **Physics** toolbar, click  **Domains** and choose **O2 Gas Diffusion Electrode**.

2 In the **Settings** window for **O2 Gas Diffusion Electrode**, locate the **Domain Selection** section.

3 From the **Selection** list, choose **Cathode Gas Diffusion Electrode**.

#### *O2 Gas Flow Channel I*

1 In the **Physics** toolbar, click  **Domains** and choose **O2 Gas Flow Channel**.

2 In the **Settings** window for **O2 Gas Flow Channel**, locate the **Domain Selection** section.

3 From the **Selection** list, choose **Cathode Flow Channel**.

### **ADD MATERIAL**

1 In the **Home** toolbar, click  **Add Material** to open the **Add Material** window.

2 Go to the **Add Material** window.

3 In the tree, select **Fuel Cell and Electrolyzer>Solid Oxides>Yttria-Stabilized Zirconia, 8YSZ, (ZrO2)0.92-(Y2O3)0.08**.

4 Right-click and choose **Add to Component I (comp1)**.

5 In the **Home** toolbar, click  **Add Material** to close the **Add Material** window.

In the **Electrolyte Phase** node, the electrolyte conductivity is set to be taken from the **Materials** node. In the **H2 Gas Phase** and **O2 Gas Phase** nodes, the settings are either the default option or automatically set by the multiphysics coupling nodes.

### **HYDROGEN FUEL CELL (FC)**

#### *H2 Gas Diffusion Electrode I*

Set up the properties of the **H2 Gas Diffusion Electrode** node. The details of electrode kinetics are set in the child node. Note that the reference equilibrium potential is calculated automatically when the default **Built in** option is used.

1 In the **Settings** window for **H2 Gas Diffusion Electrode**, locate the **Electrode Charge Transport** section.

2 In the  $\sigma_g$  text field, type  $k_{\text{seff\_a}}$ .

3 Locate the **Effective Electrolyte Charge Transport** section. From the **Effective conductivity correction** list, choose **User defined**. In the  $f_1$  text field, type  $f1\_a$ .

4 Locate the **Gas Transport** section. In the  $\epsilon_g$  text field, type  $e\_por$ .



### *H2 Gas Diffusion Electrode Reaction 1*

- 1 In the **Model Builder** window, click **H2 Gas Diffusion Electrode Reaction 1**.
- 2 In the **Settings** window for **H2 Gas Diffusion Electrode Reaction**, click to expand the **Reference Pressures** section.
- 3 In the  $p_{\text{H}_2,\text{ref}}$  text field, type p\_h2ref.
- 4 In the  $p_{\text{H}_2\text{O},\text{ref}}$  text field, type p\_h2oref\_a.
- 5 Locate the **Electrode Kinetics** section. In the  $i_{0,\text{ref}}(T)$  text field, type i0\_a.
- 6 Locate the **Active Specific Surface Area** section. In the  $a_v$  text field, type Sa\_a.

### *O2 Gas Diffusion Electrode 1*

Similarly, set up the properties of the **O2 Gas Diffusion Electrode** node. The details of electrode kinetics are set in the child node. Note that the reference equilibrium potential is calculated automatically when the default **Built in** option is used.

- 1 In the **Model Builder** window, under **Component 1 (comp1)>Hydrogen Fuel Cell (fc)** click **O2 Gas Diffusion Electrode 1**.
- 2 In the **Settings** window for **O2 Gas Diffusion Electrode**, locate the **Electrode Charge Transport** section.
- 3 In the  $\sigma_s$  text field, type kseff\_c.
- 4 Locate the **Effective Electrolyte Charge Transport** section. From the **Effective conductivity correction** list, choose **User defined**. In the  $f_1$  text field, type f1\_c.
- 5 Locate the **Gas Transport** section. In the  $\epsilon_g$  text field, type e\_por.

### *O2 Gas Diffusion Electrode Reaction 1*

- 1 In the **Model Builder** window, click **O2 Gas Diffusion Electrode Reaction 1**.
- 2 In the **Settings** window for **O2 Gas Diffusion Electrode Reaction**, click to expand the **Reference Pressures** section.
- 3 In the  $p_{\text{O}_2,\text{ref}}$  text field, type p\_o2ref.
- 4 Locate the **Electrode Kinetics** section. In the  $i_{0,\text{ref}}(T)$  text field, type i0\_c.
- 5 Locate the **Active Specific Surface Area** section. In the  $a_v$  text field, type Sa\_c.

There are no settings required on the flow channel nodes, other than the domain selection. Next, set up the boundary conditions and initial values.

### *Electronic Conducting Phase 1*

- In the **Model Builder** window, under **Component 1 (comp1)>Hydrogen Fuel Cell (fc)** click **Electronic Conducting Phase 1**.

### *Electric Ground 1*

- 1 In the **Physics** toolbar, click  **Attributes** and choose **Electric Ground**.
- 2 Select Boundaries 3 and 20 only.

### *Electronic Conducting Phase 1*

In the **Model Builder** window, click **Electronic Conducting Phase 1**.

### *Electric Potential 1*

- 1 In the **Physics** toolbar, click  **Attributes** and choose **Electric Potential**.
- 2 Select Boundaries 10 and 22 only.
- 3 In the **Settings** window for **Electric Potential**, locate the **Electric Potential** section.
- 4 In the  $\phi_{s,bnd}$  text field, type  $V_{cell}$ .

### *Initial Values 1*

- 1 In the **Model Builder** window, expand the **Component 1 (comp1)>Hydrogen Fuel Cell (fc)>H2 Gas Phase 1** node, then click **Initial Values 1**.
- 2 In the **Settings** window for **Initial Values**, locate the **Initial Composition** section.
- 3 In the  $x_{0,H2O}$  text field, type  $x_{h2oref\_a}$ .

### *H2 Gas Phase 1*

In the **Model Builder** window, click **H2 Gas Phase 1**.

### *H2 Inlet 1*

- 1 In the **Physics** toolbar, click  **Attributes** and choose **H2 Inlet**.
- 2 Select Boundary 11 only.
- 3 In the **Settings** window for **H2 Inlet**, locate the **Mixture Specification** section.
- 4 From the list, choose **Mass fractions**.
- 5 In the  $\omega_{0,H2O}$  text field, type  $w_{h2oref\_a}$ .

### *H2 Gas Phase 1*

In the **Model Builder** window, click **H2 Gas Phase 1**.

### *H2 Outlet 1*

- 1 In the **Physics** toolbar, click  **Attributes** and choose **H2 Outlet**.
- 2 Select Boundary 29 only.

### *Initial Values 1*

- 1 In the **Model Builder** window, under **Component 1 (comp1)>Hydrogen Fuel Cell (fc)>O2 Gas Phase 1** click **Initial Values 1**.

- 2 In the **Settings** window for **Initial Values**, locate the **Initial Composition** section.
- 3 In the  $x_{0,H_2O}$  text field, type  $x_{h2oref\_c}$ .
- 4 In the  $x_{0,N_2}$  text field, type  $x_{n2ref}$ .

#### *O2 Gas Phase I*

In the **Model Builder** window, click **O2 Gas Phase I**.

#### *O2 Inlet I*

- 1 In the **Physics** toolbar, click  **Attributes** and choose **O2 Inlet**.
- 2 Select Boundary 30 only.
- 3 In the **Settings** window for **O2 Inlet**, locate the **Mixture Specification** section.
- 4 From the list, choose **Mass fractions**.
- 5 In the  $\omega_{0,H_2O}$  text field, type  $w_{h2oref\_c}$ .
- 6 In the  $\omega_{0,N_2}$  text field, type  $w_{n2ref}$ .

#### *O2 Gas Phase I*

In the **Model Builder** window, click **O2 Gas Phase I**.

#### *O2 Outlet I*

- 1 In the **Physics** toolbar, click  **Attributes** and choose **O2 Outlet**.
- 2 Select Boundary 15 only.

### **FREE AND POROUS MEDIA FLOW - CATHODE (FP)**

Next, set up the fluid flow model on the cathode side. Note that the flow is compressible.

- 1 In the **Model Builder** window, under **Component 1 (comp1)** click **Free and Porous Media Flow - Cathode (fp)**.
- 2 In the **Settings** window for **Free and Porous Media Flow**, locate the **Physical Model** section.
- 3 From the **Compressibility** list, choose **Compressible flow (Ma<0.3)**.  
Define the pressure reference level in the interface properties.
- 4 In the  $p_{ref}$  text field, type  $p_{atm}$ .

Set up the properties of the porous gas diffusion electrode and the flow channel, followed by the boundary conditions. Note that the density and viscosity of the gas mixture are calculated by the **Hydrogen Fuel Cell** interface and automatically set by the multiphysics coupling nodes.

#### *Porous Medium I*

- 1 In the **Physics** toolbar, click  **Domains** and choose **Porous Medium**.

- 2 In the **Settings** window for **Porous Medium**, locate the **Domain Selection** section.
- 3 From the **Selection** list, choose **Cathode Gas Diffusion Electrode**.

#### *Porous Matrix 1*

- 1 In the **Model Builder** window, click **Porous Matrix 1**.
- 2 In the **Settings** window for **Porous Matrix**, locate the **Matrix Properties** section.
- 3 From the  $\epsilon_p$  list, choose **User defined**. In the associated text field, type e\_por.
- 4 From the  $\kappa$  list, choose **User defined**. In the associated text field, type perm\_c.

#### *Inlet 1*

- 1 In the **Physics** toolbar, click  **Boundaries** and choose **Inlet**.
- 2 Select Boundary 30 only.
- 3 In the **Settings** window for **Inlet**, locate the **Boundary Condition** section.
- 4 From the list, choose **Pressure**.
- 5 Locate the **Pressure Conditions** section. In the  $p_0$  text field, type dp\_c.

#### *Outlet 1*

- 1 In the **Physics** toolbar, click  **Boundaries** and choose **Outlet**.
- 2 Select Boundary 15 only.
- 3 In the **Settings** window for **Outlet**, locate the **Pressure Conditions** section.
- 4 Select the **Normal flow** check box.

#### *Wall 2*

- 1 In the **Physics** toolbar, click  **Boundaries** and choose **Wall**.
- 2 Select Boundaries 8 and 25 only.
- 3 In the **Settings** window for **Wall**, locate the **Boundary Condition** section.
- 4 From the **Wall condition** list, choose **Slip**.

### **FREE AND POROUS MEDIA FLOW - ANODE (FP2)**

Set up the fluid flow model on the anode side in the same way.

- 1 In the **Model Builder** window, under **Component 1 (comp1)** click **Free and Porous Media Flow - Anode (fp2)**.
- 2 In the **Settings** window for **Free and Porous Media Flow**, locate the **Physical Model** section.
- 3 From the **Compressibility** list, choose **Compressible flow (Ma<0.3)**.  
Define the pressure reference level in the interface properties.
- 4 In the  $p_{\text{ref}}$  text field, type p\_atm.

### *Porous Medium 1*

- 1 In the **Physics** toolbar, click  **Domains** and choose **Porous Medium**.
- 2 In the **Settings** window for **Porous Medium**, locate the **Domain Selection** section.
- 3 From the **Selection** list, choose **Anode Gas Diffusion Electrode**.

### *Porous Matrix 1*

- 1 In the **Model Builder** window, click **Porous Matrix 1**.
- 2 In the **Settings** window for **Porous Matrix**, locate the **Matrix Properties** section.
- 3 From the  $\epsilon_p$  list, choose **User defined**. In the associated text field, type e\_por.
- 4 From the  $\kappa$  list, choose **User defined**. In the associated text field, type perm\_a.

### *Inlet 1*

- 1 In the **Physics** toolbar, click  **Boundaries** and choose **Inlet**.
- 2 Select Boundary 11 only.
- 3 In the **Settings** window for **Inlet**, locate the **Boundary Condition** section.
- 4 From the list, choose **Pressure**.
- 5 Locate the **Pressure Conditions** section. In the  $p_0$  text field, type dp\_a.

### *Outlet 1*

- 1 In the **Physics** toolbar, click  **Boundaries** and choose **Outlet**.
- 2 Select Boundary 29 only.
- 3 In the **Settings** window for **Outlet**, locate the **Pressure Conditions** section.
- 4 Select the **Normal flow** check box.

### *Wall 2*

- 1 In the **Physics** toolbar, click  **Boundaries** and choose **Wall**.
- 2 Select Boundaries 2 and 23 only.
- 3 In the **Settings** window for **Wall**, locate the **Boundary Condition** section.
- 4 From the **Wall condition** list, choose **Slip**.

## **GLOBAL DEFINITIONS**

### *Default Model Inputs*

**Default Model Inputs** node can be used to set the **Temperature** for the entire model. This node may be accessed by multiple physics nodes.

- 1 In the **Model Builder** window, under **Global Definitions** click **Default Model Inputs**.
- 2 In the **Settings** window for **Default Model Inputs**, locate the **Browse Model Inputs** section.

- 3 In the tree, select **General>Temperature (K) - minput.T**.
- 4 Find the **Expression for remaining selection** subsection. In the **Temperature** text field, type T.

### **MESH I**

The physics settings for the model is now complete. A mapped mesh, swept in the channel direction, is suitable for this geometry. Control the size in the *y* direction by using an individual **Edge** node.

#### *Edge 1*

- 1 In the **Mesh** toolbar, click  **Boundary** and choose **Edge**.
- 2 Select Edges 2, 10, 15, 18, 24, and 27 only.

#### *Size 1*

- 1 Right-click **Edge 1** and choose **Size**.
- 2 In the **Settings** window for **Size**, locate the **Element Size** section.
- 3 Click the **Custom** button.
- 4 Locate the **Element Size Parameters** section. Select the **Maximum element size** check box.
- 5 In the associated text field, type  $W_{\text{channel}}/8$ .
- 6 Click  **Build Selected**.

#### *Mapped 1*

- 1 In the **Mesh** toolbar, click  **Boundary** and choose **Mapped**.
- 2 Select Boundaries 1, 4, 7, 11, and 15 only.

#### *Distribution 1*

- 1 Right-click **Mapped 1** and choose **Distribution**.
- 2 Select Edges 12, 17, 22, and 26 only.
- 3 In the **Settings** window for **Distribution**, locate the **Distribution** section.
- 4 From the **Distribution type** list, choose **Predefined**.
- 5 In the **Number of elements** text field, type 10.
- 6 In the **Element ratio** text field, type 3.
- 7 Select the **Symmetric distribution** check box.

#### *Distribution 2*

- 1 In the **Model Builder** window, right-click **Mapped 1** and choose **Distribution**.
- 2 Select Edges 7 and 34 only.

- 3 In the **Settings** window for **Distribution**, locate the **Distribution** section.
- 4 From the **Distribution type** list, choose **Predefined**.
- 5 In the **Number of elements** text field, type 8.
- 6 In the **Element ratio** text field, type 3.

#### *Distribution 3*

- 1 Right-click **Distribution 2** and choose **Duplicate**.
- 2 In the **Settings** window for **Distribution**, locate the **Edge Selection** section.
- 3 Click  **Clear Selection**.
- 4 Select Edges 1 and 30 only.
- 5 Locate the **Distribution** section. Select the **Reverse direction** check box.

#### *Distribution 4*

- 1 In the **Model Builder** window, right-click **Mapped 1** and choose **Distribution**.
- 2 Select Edges 4 and 32 only.
- 3 In the **Settings** window for **Distribution**, locate the **Distribution** section.
- 4 In the **Number of elements** text field, type 3.

#### *Mapped 1*

Right-click **Mapped 1** and choose **Build Selected**.

#### *Swept 1*

In the **Mesh** toolbar, click  **Swept**.

#### *Size 1*

- 1 Right-click **Swept 1** and choose **Size**.
- 2 In the **Settings** window for **Size**, locate the **Element Size** section.
- 3 Click the **Custom** button.
- 4 Locate the **Element Size Parameters** section. Select the **Maximum element size** check box.
- 5 In the associated text field, type W\_channe1.
- 6 Click  **Build All**.

7 Click the  **Zoom Extents** button in the **Graphics** toolbar.

The meshing is now complete, and it should look like that in the figure below.

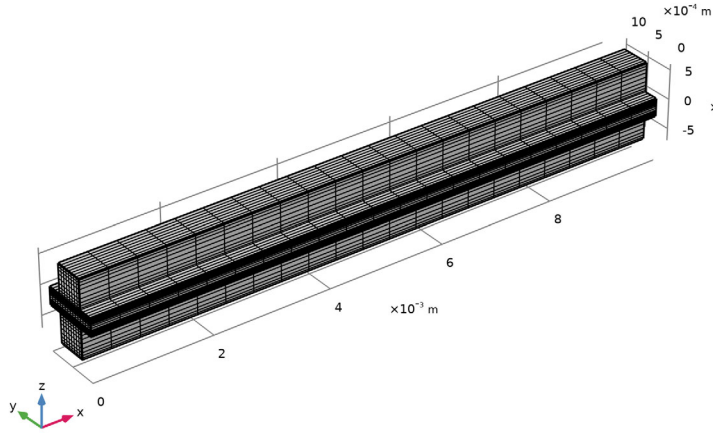

## DEFINITIONS

Before solving, add a probe for the average cell current density, it will be plotted during the solver process.

### Cell Current Density Probe

- 1 In the **Definitions** toolbar, click  **Probes** and choose **Domain Probe**.
- 2 In the **Settings** window for **Domain Probe**, type Cell Current Density Probe in the **Label** text field.
- 3 In the **Variable name** text field, type  $I_{cell}$ .
- 4 Locate the **Source Selection** section. From the **Selection** list, choose **Anode Gas Diffusion Electrode**.
- 5 Click **Replace Expression** in the upper-right corner of the **Expression** section. From the menu, choose **Component 1 (comp1)>Hydrogen Fuel Cell>Electrode kinetics>fc.ivtot - Electrode reaction source - A/m<sup>2</sup>**.
- 6 Locate the **Expression** section. In the **Expression** text field, type  $fc.ivtot * H_{gde}$ .
- 7 Select the **Description** check box.
- 8 In the associated text field, type Average cell current density.



## STUDY 1

The problem is now ready for solving. Firstly, solve for current distribution initialization (both primary and secondary) in two study steps, followed by flow in two subsequent study steps. Finally, solve the entire model including the multiphysics couplings in the final step, along with an auxiliary sweep with continuation to solve for a range of different cell polarization voltages.

### *Step 1: Current Distribution Initialization*

- 1 In the **Model Builder** window, under **Study 1** click **Step 1: Current Distribution Initialization**.
- 2 In the **Settings** window for **Current Distribution Initialization**, locate the **Physics and Variables Selection** section.
- 3 In the table, clear the **Solve for** check boxes for **Reacting Flow, H2 Gas Phase 1 (rfh1)** and **Reacting Flow, O2 Gas Phase 1 (rfo1)**.

### *Current Distribution Initialization 2*

- 1 In the **Study** toolbar, click  **Study Steps** and choose **Other>Current Distribution Initialization**.
- 2 Drag and drop below **Step 1: Current Distribution Initialization**.
- 3 In the **Settings** window for **Current Distribution Initialization**, locate the **Study Settings** section.
- 4 From the **Current distribution type** list, choose **Secondary**.
- 5 Locate the **Physics and Variables Selection** section. In the table, clear the **Solve for** check boxes for **Reacting Flow, H2 Gas Phase 1 (rfh1)** and **Reacting Flow, O2 Gas Phase 1 (rfo1)**.

### *Step 3: Stationary*



- 1 In the **Model Builder** window, click **Step 3: Stationary**.
- 2 In the **Settings** window for **Stationary**, locate the **Physics and Variables Selection** section.
- 3 In the table, clear the **Solve for** check boxes for **Hydrogen Fuel Cell (fc)** and **Free and Porous Media Flow - Anode (fp2)**.
- 4 In the table, clear the **Solve for** check boxes for **Reacting Flow, H2 Gas Phase 1 (rfh1)** and **Reacting Flow, O2 Gas Phase 1 (rfo1)**.

### *Stationary 2*

- 1 In the **Study** toolbar, click  **Study Steps** and choose **Stationary>Stationary**.
- 2 In the **Settings** window for **Stationary**, locate the **Physics and Variables Selection** section.
- 3 In the table, clear the **Solve for** check boxes for **Hydrogen Fuel Cell (fc)** and **Free and Porous Media Flow - Cathode (fp)**.

- In the table, clear the **Solve for** check boxes for **Reacting Flow, H2 Gas Phase I (rfh1)** and **Reacting Flow, O2 Gas Phase I (rfo1)**.

#### Stationary 3

- In the **Study** toolbar, click  **Study Steps** and choose **Stationary>Stationary**.
- In the **Settings** window for **Stationary**, click to expand the **Study Extensions** section.
- Select the **Auxiliary sweep** check box.
- Click  **Add**.
- In the table, enter the following settings:

Parameter name	Parameter value list	Parameter unit
V_pol (Initial cell polarization)	0.05 range (0.1, 0.1, 0.8)	V

- In the **Study** toolbar, click  **Compute**.

The computation takes a few minutes.

## RESULTS

Several default plots are generated. Among them are the plots seen in [Figure 2](#) and [Figure 3](#) that show the oxygen and hydrogen mole fraction distribution, respectively, at a cell voltage of 0.8 V.

#### Polarization Curve

The following instructions reproduce the plot of the polarization curve for the SOFC (see [Figure 5](#)).

- In the **Home** toolbar, click  **Add Plot Group** and choose **ID Plot Group**.
- In the **Settings** window for **ID Plot Group**, type Polarization Curve in the **Label** text field.
- Click to expand the **Title** section. From the **Title type** list, choose **Manual**.
- In the **Title** text area, type Polarization curve.
- Locate the **Plot Settings** section. Select the **x-axis label** check box.
- In the associated text field, type Average current density ( $A/m^2$ ).
- Select the **y-axis label** check box.
- In the associated text field, type  $V_{cell}$  (V).

#### Global 1

- Right-click **Polarization Curve** and choose **Global**.

2 In the **Settings** window for **Global**, locate the **y-Axis Data** section.

3 In the table, enter the following settings:

Expression	Unit	Description
V_cell	V	Cell Voltage

4 Locate the **x-Axis Data** section. From the **Parameter** list, choose **Expression**.

5 In the **Expression** text field, type I\_cell.

6 In the **Polarization Curve** toolbar, click  **Plot**.

#### *Power vs. Current*

Next, reproduce a plot showing the power output as a function of the cell voltage (Figure 6).

1 In the **Home** toolbar, click  **Add Plot Group** and choose **ID Plot Group**.

2 In the **Settings** window for **ID Plot Group**, type Power vs. Current in the **Label** text field.

3 Locate the **Title** section. From the **Title type** list, choose **Manual**.

4 In the **Title** text area, type Total output power.

5 Locate the **Plot Settings** section. Select the **x-axis label** check box.

6 In the associated text field, type Average current density (A/m<sup>2</sup>).

7 Select the **y-axis label** check box.

8 In the associated text field, type Average Cell Power (W/m<sup>2</sup>).

#### *Global I*

1 Right-click **Power vs. Current** and choose **Global**.

2 In the **Settings** window for **Global**, locate the **y-Axis Data** section.

3 In the table, enter the following settings:

Expression	Unit	Description
V_cell*I_cell	W/m <sup>2</sup>	Average Cell Power

4 Locate the **x-Axis Data** section. From the **Parameter** list, choose **Expression**.

5 In the **Expression** text field, type I\_cell.

6 In the **Power vs. Current** toolbar, click  **Plot**.

#### *Electrolyte Current Density*



Next reproduce the plot in Figure 4 showing the current density in the unit cell at 0.8 V.

- 1 In the **Home** toolbar, click  **Add Plot Group** and choose **3D Plot Group**.
- 2 In the **Settings** window for **3D Plot Group**, type Electrolyte Current Density in the **Label** text field.

#### *Surface 1*

- 1 Right-click **Electrolyte Current Density** and choose **Surface**.
- 2 In the **Settings** window for **Surface**, click **Replace Expression** in the upper-right corner of the **Expression** section. From the menu, choose **Component 1 (comp1)>Hydrogen Fuel Cell>Electrolyte current density vector - A/m²>fc.llz - Electrolyte current density vector, z component**.

#### *Selection 1*

- 1 Right-click **Surface 1** and choose **Selection**.
- 2 Select Boundary 9 only.
- 3 In the **Electrolyte Current Density** toolbar, click  **Plot**.
- 4 Click the  **Zoom Extents** button in the **Graphics** toolbar.