



Chamber Music Hall

Introduction

The main purpose of performance spaces such as concert halls is to deliver sound of high quality to the audience; acoustic conditions are therefore of utmost importance. These conditions can be investigated numerically to predict the behavior of the room before the building or renovation phase is started. In spaces with large dimensions compared to the wavelengths of interest, like the one at hand, acoustic ray tracing is the best fitted solution for numerical simulations.

This model studies the acoustics of the Small Hall in the Konzerthaus Berlin. It is a moderately sized hall with 386 seats, primarily used for chamber music concerts. The model is set up with the *Ray Acoustics* physics interface. The room acoustic parameters are derived from impulse responses with 10 pairs of source-receiver positions, and the results are compared to in-situ measurements (see [Ref. 1](#)). The goal of this study is to assess the accuracy of the calculations; for a detailed guide on how to set up a room acoustic simulation see the [Small Concert Hall Acoustics](#) model, also included in the Acoustics Module Application Library.

Note: The geometry model, room data, and measurement data used here were provided by the authors of [Ref. 1](#) and [Ref. 2](#) under the [Creative Commons BY-SA 4.0](#) license; the public database can be found in [Ref. 2](#). One modification has been made to the geometry model: the seating on the central area and on the balconies has been extruded to a height of 0.8 m instead of being represented as flat surfaces.

Model Definition

The model represents a concert hall with a volume $V = 2350 \text{ m}^3$, excluding the coupled attic volume. The geometry was provided by [Ref. 2](#), as well as the assignment of materials to the different surfaces, absorption and scattering data, source and receiver positions, and measurement data. The only modification that has been made to the provided material is the geometry of the seating area. In the original model, the central seats on the ground floor and the seats on the balcony are represented as flat surfaces, whereas in this study they have been extruded to a height of 0.8 m. The inside of the hall geometry can be seen in [Figure 1](#).

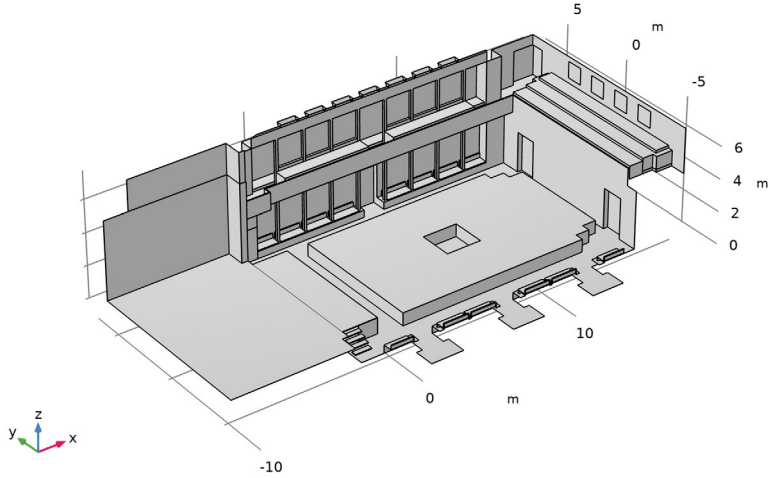

Figure 1: Interior geometry of the chamber music hall.

The simulation is performed in 1/3-octave bands ranging from 100 Hz to 5000 Hz. Two omnidirectional source positions are defined on the stage, together with five receiver positions spread over the central seating area. Their coordinates are given in Table 1, with the location of the origin centered at the foot of the stage.

TABLE 1: SOURCE AND RECEIVER POSITIONS.

POINT	X-COORDINATE	Y-COORDINATE	Z-COORDINATE
Source 1	-2.02 m	2 m	2.38 m
Source 2	-3.32 m	-2 m	2.38 m
Receiver 1	7.84 m	0 m	1.23 m
Receiver 2	2.165 m	3.441 m	1.23 m
Receiver 3	9.227 m	2.366 m	1.23 m
Receiver 4	5.86 m	-2.359 m	1.23 m
Receiver 5	12.726 m	-3.24 m	1.23 m

The size of the receivers is set to match the width of one seat, with a receiver radius $r = 0.3$ m. The number of rays emitted by each source is then determined to limit the error

in the calculated impulse responses. For an expected error of 1 dB in every time interval Δt of the response, the number of rays should be (see [Ref. 3](#))

$$N_{\text{rays}} = 4.34^2 \frac{V}{\pi r^2 c \Delta t} \quad (1)$$

With $\Delta t = 0.01$ s, the resulting value is rounded up to $N_{\text{rays}} = 46000$. Boundary conditions are defined as absorption and scattering coefficients in 1/3-octave bands. The amplitude attenuation of air was computed at the 1/3-octave band center frequencies from a *Pressure Acoustics* model and is imported from the file `chamber_music_hall_air_attenuation.txt`.

Results and Discussion

The power carried by each ray emitted from source 1 at 5000 Hz is shown in [Figure 2](#) at different times. In this model the intensity along each ray is not computed in order to limit the number of degrees of freedom solved for in the simulation, hence reducing the computation time and the size of the saved file. As a result, it is not possible to plot local wavefront variables that depend on curvature computation, such as the sound pressure level. Nevertheless, the acoustic power and the reflection count along each ray are sufficient to generate the room impulse responses.

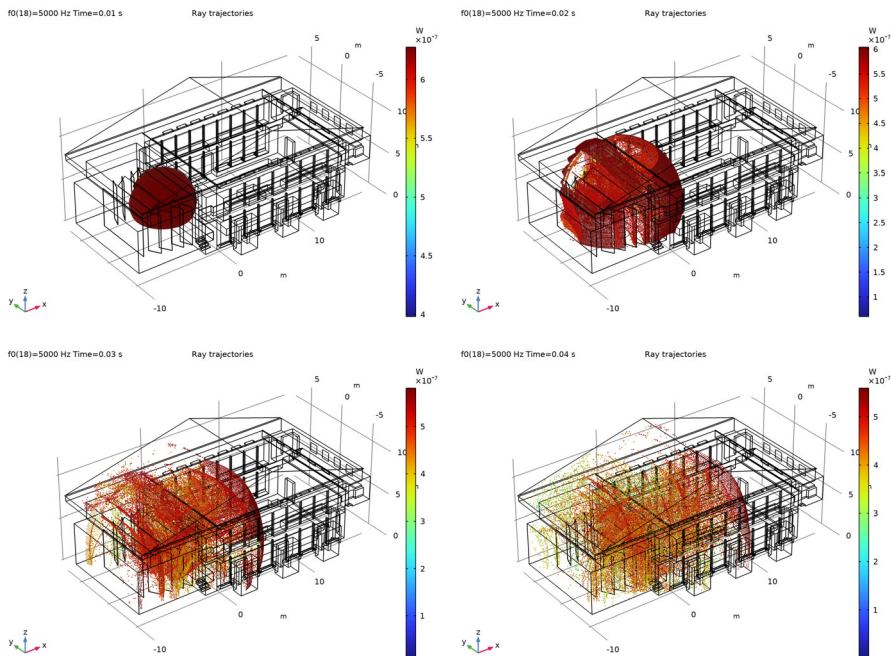

Figure 2: Ray location and power from source 1 at 5000 Hz after 10 ms (top left), 20 ms (top right), 30 ms (bottom left), and 40 ms (bottom right).

The impulse response energy decay used to compute the room acoustic parameters for one source-receiver pair is found in Figure 3. The curves are seen to be smooth from 0 dB to at least -40 dB, and the response duration is long enough to allow the necessary decay for reverberation time calculation. The results obtained should therefore be reliable.

Similarly to measurement procedures, level decay curves are generated for all the source-receiver pairs in the model. Hence, 10 values are derived for each room acoustic parameter. The average over the 10 source-receiver pairs is then calculated to obtain an overall value for the room.

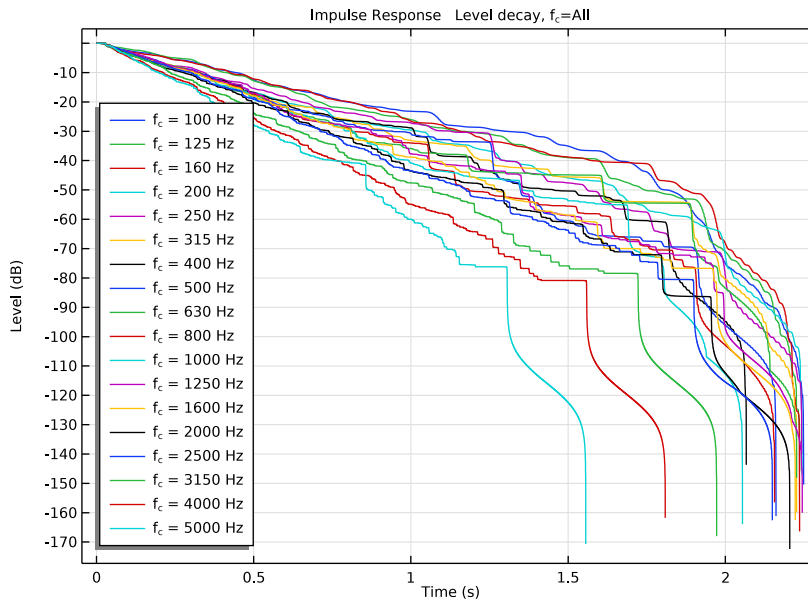

Figure 3: Level decay curves for source 1 and receiver 1.

The comparison between the measured and calculated Early Decay Time (EDT) is plotted in Figure 4. The interval representing three times the just noticeable difference (JND) is also depicted. A satisfying match is observed, with the result of the calculation lying within 3 JND of the measurement in many 1/3-octave bands or slightly above this interval otherwise.

The measured and calculated reverberation times T20 are also compared in Figure 5. In this case, the reverberation time is overestimated by the calculation. This finding concurs with Ref. 1, where T20 was overestimated by all the simulation algorithms. Since this issue did not arise in the EDT, the difference between measurement and calculation does not originate from the early part of the sound field.

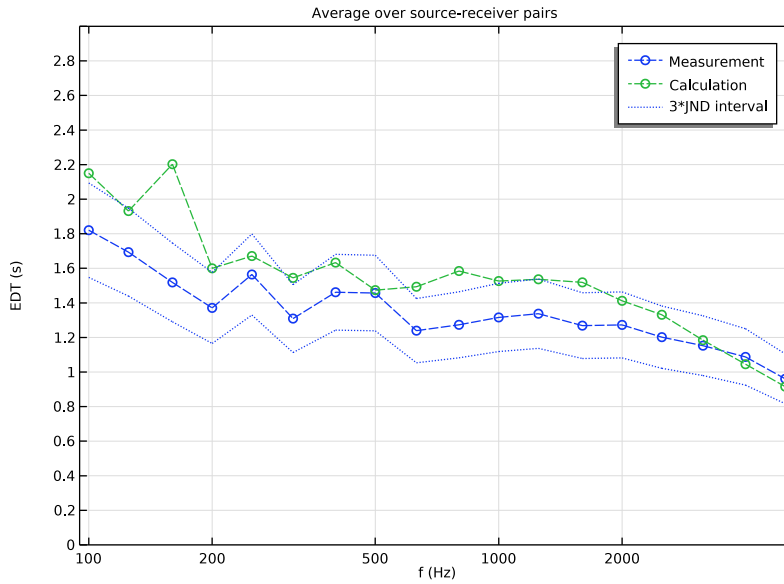

Figure 4: Early Decay Time averaged across the room.

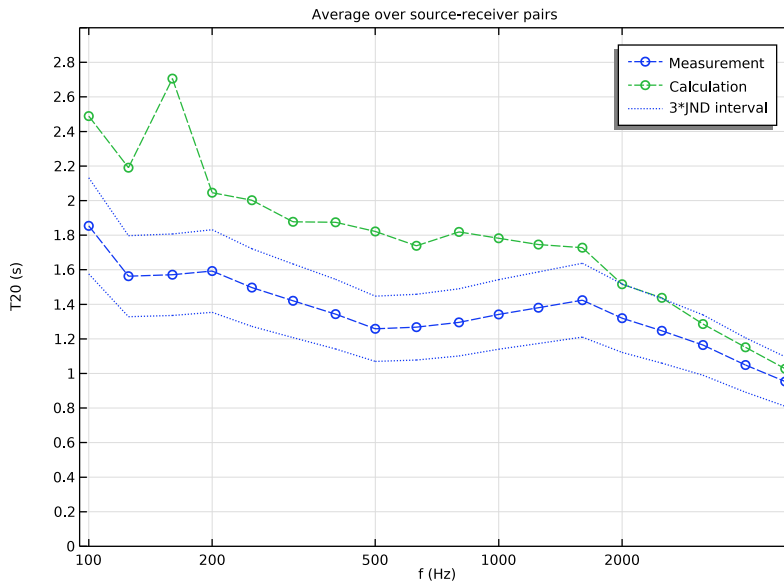

Figure 5: Reverberation time T_{20} averaged across the room.

Two more acoustics parameters, the clarity C80 and the definition D, are shown in [Figure 6](#) and [Figure 7](#) respectively. They both fit nicely with the measurements and appear well within the 3 JND interval over the whole frequency range.

In the subjective perception of room acoustics, early reflections that reach listeners before 50 ms to 100 ms are considered to contribute positively by reinforcing the direct sound (see [Ref. 4](#)). C80 and D both give an indication of this aspect with their energy ratios of early sound field to either late or total sound field. The difference in their definitions of the transition between early and late reflections stems from their respective purposes, with C80 describing the transparency of music and D the speech intelligibility. Moreover, EDT only takes into account the first 10 dB of the level decay to focus on the early energy. As a result, it is more closely related to the perceived reverberance of a room than other quantifications of reverberation time. Finding a good fit with the measurements in these three parameters is therefore an encouraging sign for the accuracy of the simulation.

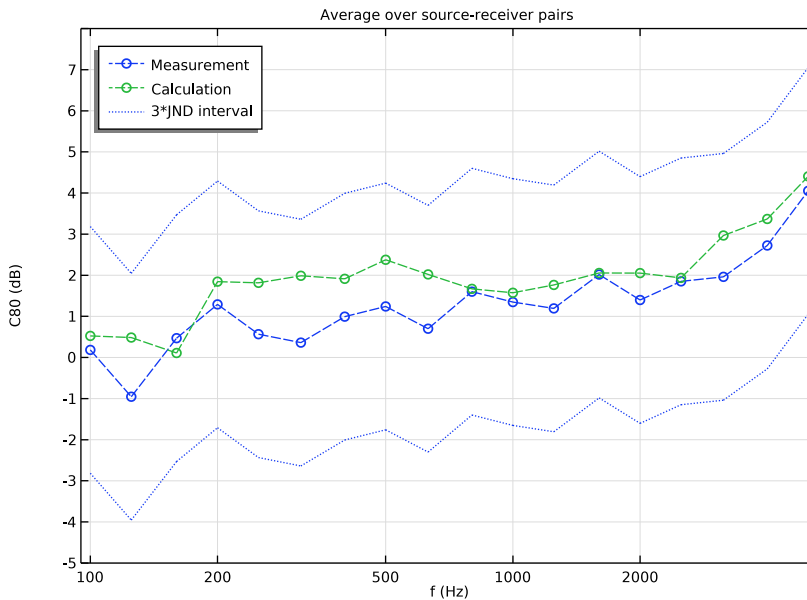

Figure 6: Clarity C80 averaged across the room.

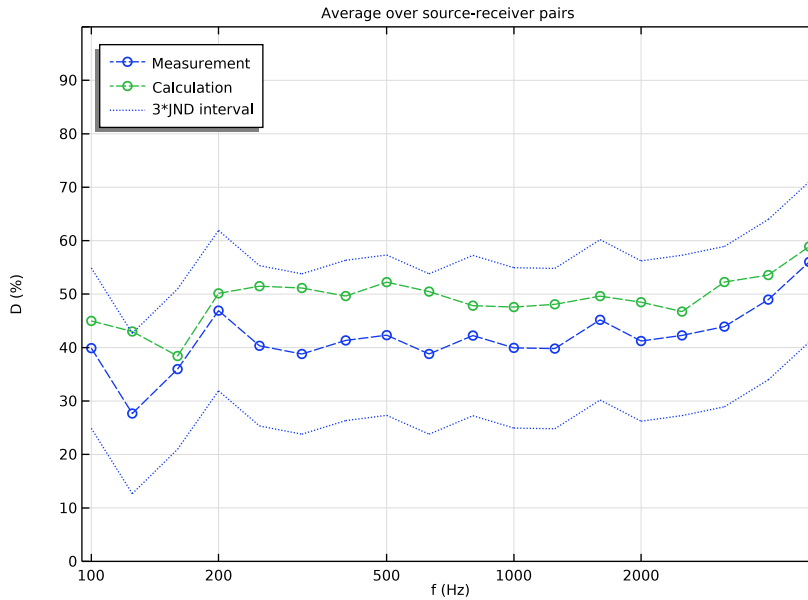

Figure 7: Definition D averaged across the room.

Overall, a good accuracy has been found in the study of this chamber music hall. The calculation results matched closely with in-situ measurements for most of the common room acoustic parameters. This demonstrates the potential for modeling advanced room acoustic cases.

Notes About the COMSOL Implementation

The rays that are emitted in the simulation need to be terminated when their energy content becomes too small to avoid unnecessary calculations. This can be done by defining a power threshold as termination criterion. With the total source power P_0 , each ray is emitted with an initial power P_0/N_{rays} . In this model, a ray is terminated when the power it carries is 10^6 times smaller than initially, in other words when its power has dropped by 60 dB. The power threshold for termination is then expressed as $P_0/N_{\text{rays}} \cdot 10^{-6}$.

When plotting an energy decay curve, the EDT and reverberation times are automatically checked to detect potentially large differences. These can be due to a small number of rays or an early termination of the rays and simulation. In this model, a warning might appear

depending on the random effects of scattering; however, the comparison with measurement data shows that the simulation is well set.

Some postprocessing is needed in this model in order to obtain results averaged over the room. After calculating the impulse responses, the acoustic parameters for the different source-receiver pairs must be interpolated as functions of frequency. First, an **Interpolation** is created for each impulse response under **Global Definitions**. A new **Study** is then added with the same **Parametric Sweep** as the previous ones but no ray tracing step. The role of this study is to load the newly created interpolation functions without running a full calculation of the model again, its output results are therefore non-relevant. Once the new study has been computed, the acoustic parameters can be processed to return values averaged over the room.

Given the time needed to render the impulse responses, it is highly advisable to save the plot data in the model. However, this can create a very large saved file. Some disc space can be spared by setting **File>Preferences>Save>Optimize for>File size**.

References

1. F. Brinkmann, L. Aspöck, D. Ackermann, S. Lepa, M. Vorländer, and S. Weinzierl, “A round robin on room acoustical simulation and auralization,” *J. Acoust. Soc. Am.*, vol. 145, pp. 2746-2760, 2019, doi: [10.1121/1.5096178](https://doi.org/10.1121/1.5096178).
 2. L. Aspöck, F. Brinkmann, D. Ackermann, S. Weinzierl, and M. Vorländer, “BRAS - Benchmark for Room Acoustical Simulation”, 2020, doi: [10.14279/depositonce-6726.3](https://doi.org/10.14279/depositonce-6726.3).
 3. M. Vorländer, *Auralization: Fundamentals of Acoustics, Modelling, Simulation, Algorithms and Acoustic Virtual Reality*, Springer, 2008.
 4. H. Kuttruff, *Room Acoustics*, CRC Press, 2009.
-

Application Library path: Acoustics_Module/Building_and_Room_Acoustics/
chamber_music_hall

Modeling Instructions



This section contains the modeling instructions for the Chamber Music Hall model. They are followed by the [Geometry Modeling Instructions](#) section.

From the **File** menu, choose **New**.

NEW

In the **New** window, click  **Model Wizard**.

MODEL WIZARD

- 1 In the **Model Wizard** window, click  **3D**.
- 2 In the **Select Physics** tree, select **Acoustics>Geometrical Acoustics>Ray Acoustics (rac)**.
- 3 Click **Add**.
- 4 Click  **Study**.
- 5 In the **Select Study** tree, select **Preset Studies for Selected Physics Interfaces>Ray Tracing**.
- 6 Click  **Done**.

GEOMETRY 1



- 1 In the **Geometry** toolbar, click **Insert Sequence** and choose **Insert Sequence**.
- 2 Browse to the model's Application Libraries folder and double-click the file `chamber_music_hall_geom_sequence.mph`.
- 3 In the **Geometry** toolbar, click  **Build All**.
Start by loading parameter definitions, material properties, and measurement data.

GLOBAL DEFINITIONS

Parameters 1 - Study setup

- 1 In the **Model Builder** window, under **Global Definitions** click **Parameters 1**.
- 2 In the **Settings** window for **Parameters**, type Parameters 1 - Study setup in the **Label** text field.
- 3 Locate the **Parameters** section. Click  **Load from File**.
- 4 Browse to the model's Application Libraries folder and double-click the file `chamber_music_hall_parameters1.txt`.



Parameters 2 - Source and receiver positions

- 1 In the **Home** toolbar, click  **Parameters** and choose **Add>Parameters**.
- 2 In the **Settings** window for **Parameters**, type Parameters 2 - Source and receiver positions in the **Label** text field.
- 3 Locate the **Parameters** section. Click  **Load from File**.

- 4 Browse to the model's Application Libraries folder and double-click the file `chamber_music_hall_parameters2.txt`.

Create interpolation functions to import the air attenuation, the absorption and scattering coefficients of the different surfaces, and the acoustic parameters measured in the room.

Interpolation 1 (int1)

- 1 In the **Home** toolbar, click  **Functions** and choose **Global>Interpolation**.
- 2 In the **Settings** window for **Interpolation**, locate the **Definition** section.
- 3 From the **Data source** list, choose **File**.
- 4 Click  **Browse**.
- 5 Browse to the model's Application Libraries folder and double-click the file `chamber_music_hall_air_attenuation.txt`.
- 6 Click  **Import**.
- 7 From the **Data source** list, choose **File**.
- 8 Find the **Functions** subsection. In the table, enter the following settings:

Function name	Position in file
a_air	1

- 9 Locate the **Interpolation and Extrapolation** section. From the **Interpolation** list, choose **Nearest neighbor**.
- 10 Locate the **Units** section. In the **Function** table, enter the following settings:

Function	Unit
a_air	Np/m

- 11 In the **Argument** table, enter the following settings:

Argument	Unit
Column 1	Hz

- 12 Locate the **Definition** section. Click  **Import**.

Interpolation 2 (int2)

- 1 In the **Home** toolbar, click  **Functions** and choose **Global>Interpolation**.
- 2 In the **Settings** window for **Interpolation**, locate the **Definition** section.
- 3 From the **Data source** list, choose **File**.

4 Click  **Browse**.

5 Browse to the model's Application Libraries folder and double-click the file `chamber_music_hall_ceiling.csv`.

6 In the **Number of arguments** text field, type 1.

7 Find the **Functions** subsection. In the table, enter the following settings:

Function name	Position in file
a_ceiling	1
s_ceiling	2

8 Locate the **Interpolation and Extrapolation** section. From the **Interpolation** list, choose **Nearest neighbor**.

9 Locate the **Units** section. In the **Function** table, enter the following settings:

Function	Unit
a_ceiling	1
s_ceiling	1

10 In the **Argument** table, enter the following settings:

Argument	Unit
Column 1	Hz

11 Locate the **Definition** section. Click  **Import**.

Interpolation 3 (int3)

1 In the **Home** toolbar, click  **Functions** and choose **Global>Interpolation**.

2 In the **Settings** window for **Interpolation**, locate the **Definition** section.

3 From the **Data source** list, choose **File**.

4 Click  **Browse**.

5 Browse to the model's Application Libraries folder and double-click the file `chamber_music_hall_floor.csv`.

6 In the **Number of arguments** text field, type 1.

7 Find the **Functions** subsection. In the table, enter the following settings:

Function name	Position in file
a_floor	1
s_floor	2

8 Locate the **Interpolation and Extrapolation** section. From the **Interpolation** list, choose **Nearest neighbor**.

9 Locate the **Units** section. In the **Function** table, enter the following settings:

Function	Unit
a_floor	1
s_floor	1

10 In the **Argument** table, enter the following settings:

Argument	Unit
Column 1	Hz

11 Locate the **Definition** section. Click  **Import**.

Interpolation 4 (int4)

1 In the **Home** toolbar, click  **Functions** and choose **Global>Interpolation**.

2 In the **Settings** window for **Interpolation**, locate the **Definition** section.

3 From the **Data source** list, choose **File**.

4 Click  **Browse**.

5 Browse to the model's Application Libraries folder and double-click the file `chamber_music_hall_plaster.csv`.

6 In the **Number of arguments** text field, type 1.

7 Find the **Functions** subsection. In the table, enter the following settings:

Function name	Position in file
a_plaster	1
s_plaster	2

8 Locate the **Interpolation and Extrapolation** section. From the **Interpolation** list, choose **Nearest neighbor**.

9 Locate the **Units** section. In the **Function** table, enter the following settings:

Function	Unit
a_plaster	1
s_plaster	1

10 In the **Argument** table, enter the following settings:

Argument	Unit
Column 1	Hz

11 Locate the **Definition** section. Click  **Import**.

Interpolation 5 (int5)

1 In the **Home** toolbar, click  **Functions** and choose **Global>Interpolation**.

2 In the **Settings** window for **Interpolation**, locate the **Definition** section.

3 From the **Data source** list, choose **File**.

4 Click  **Browse**.

5 Browse to the model's Application Libraries folder and double-click the file `chamber_music_hall_seating.csv`.

6 In the **Number of arguments** text field, type 1.

7 Find the **Functions** subsection. In the table, enter the following settings:

Function name	Position in file
a_seating	1
s_seating	2

8 Locate the **Interpolation and Extrapolation** section. From the **Interpolation** list, choose **Nearest neighbor**.

9 Locate the **Units** section. In the **Function** table, enter the following settings:

Function	Unit
a_seating	1
s_seating	1

10 In the **Argument** table, enter the following settings:

Argument	Unit
Column 1	Hz

11 Locate the **Definition** section. Click  **Import**.

Interpolation 6 (int6)

1 In the **Home** toolbar, click  **Functions** and choose **Global>Interpolation**.

2 In the **Settings** window for **Interpolation**, locate the **Definition** section.

- 3 From the **Data source** list, choose **File**.
- 4 Click  **Browse**.
- 5 Browse to the model's Application Libraries folder and double-click the file `chamber_music_hall_stagepanels.csv`.
- 6 In the **Number of arguments** text field, type 1.
- 7 Find the **Functions** subsection. In the table, enter the following settings:

Function name	Position in file
a_stagepanels	1
s_stagepanels	2

- 8 Locate the **Interpolation and Extrapolation** section. From the **Interpolation** list, choose **Nearest neighbor**.
- 9 Locate the **Units** section. In the **Function** table, enter the following settings:



Function	Unit
a_stagepanels	1
s_stagepanels	1

- 10 In the **Argument** table, enter the following settings:

Argument	Unit
Column 1	Hz

- 11 Locate the **Definition** section. Click  **Import**.

Interpolation 7 (int7)

- 1 In the **Home** toolbar, click  **Functions** and choose **Global>Interpolation**.
- 2 In the **Settings** window for **Interpolation**, locate the **Definition** section.
- 3 From the **Data source** list, choose **File**.
- 4 Click  **Browse**.
- 5 Browse to the model's Application Libraries folder and double-click the file `chamber_music_hall_structuredplaster.csv`.
- 6 In the **Number of arguments** text field, type 1.

7 Find the **Functions** subsection. In the table, enter the following settings:

Function name	Position in file
a_structuredplaster	1
s_structuredplaster	2

8 Locate the **Interpolation and Extrapolation** section. From the **Interpolation** list, choose **Nearest neighbor**.

9 Locate the **Units** section. In the **Function** table, enter the following settings:

Function	Unit
a_structuredplaster	1
s_structuredplaster	1

10 In the **Argument** table, enter the following settings:

Argument	Unit
Column 1	Hz

11 Locate the **Definition** section. Click  **Import**.

Interpolation 8 (int8)

1 In the **Home** toolbar, click  **Functions** and choose **Global>Interpolation**.

2 In the **Settings** window for **Interpolation**, locate the **Definition** section.

3 From the **Data source** list, choose **File**.

4 Click  **Browse**.

5 Browse to the model's Application Libraries folder and double-click the file `chamber_music_hall_windows.csv`.

6 In the **Number of arguments** text field, type 1.

7 Find the **Functions** subsection. In the table, enter the following settings:

Function name	Position in file
a_windows	1
s_windows	2

8 Locate the **Interpolation and Extrapolation** section. From the **Interpolation** list, choose **Nearest neighbor**.

9 Locate the **Units** section. In the **Function** table, enter the following settings:

Function	Unit
a_windows	1
s_windows	1

10 In the **Argument** table, enter the following settings:

Argument	Unit
Column I	Hz

11 Locate the **Definition** section. Click  **Import**.

Interpolation 9 (int9)

1 In the **Home** toolbar, click  **Functions** and choose **Global>Interpolation**.

2 In the **Settings** window for **Interpolation**, locate the **Definition** section.

3 From the **Data source** list, choose **File**.

4 Click  **Browse**.

5 Browse to the model's Application Libraries folder and double-click the file chamber_music_hall_EDT.txt.

6 In the **Number of arguments** text field, type 1.

7 Find the **Functions** subsection. In the table, enter the following settings:

Function name	Position in file
EDT_meas	1

8 Locate the **Interpolation and Extrapolation** section. From the **Interpolation** list, choose **Nearest neighbor**.

9 Locate the **Units** section. In the **Function** table, enter the following settings:



Function	Unit
EDT_meas	s

10 In the **Argument** table, enter the following settings:

Argument	Unit
Column I	Hz

11 Locate the **Definition** section. Click  **Import**.

Interpolation 10 (int10)

- 1 In the **Home** toolbar, click  **Functions** and choose **Global>Interpolation**.
- 2 In the **Settings** window for **Interpolation**, locate the **Definition** section.
- 3 From the **Data source** list, choose **File**.
- 4 Click  **Browse**.
- 5 Browse to the model's Application Libraries folder and double-click the file `chamber_music_hall_T20.txt`.
- 6 In the **Number of arguments** text field, type 1.
- 7 Find the **Functions** subsection. In the table, enter the following settings:

Function name	Position in file
T20_meas	1

- 8 Locate the **Interpolation and Extrapolation** section. From the **Interpolation** list, choose **Nearest neighbor**.
- 9 Locate the **Units** section. In the **Function** table, enter the following settings:



Function	Unit
T20_meas	s

- 10 In the **Argument** table, enter the following settings:

Argument	Unit
Column 1	Hz

- 11 Locate the **Definition** section. Click  **Import**.

Interpolation 11 (int11)

- 1 In the **Home** toolbar, click  **Functions** and choose **Global>Interpolation**.
- 2 In the **Settings** window for **Interpolation**, locate the **Definition** section.
- 3 From the **Data source** list, choose **File**.
- 4 Click  **Browse**.
- 5 Browse to the model's Application Libraries folder and double-click the file `chamber_music_hall_C80.txt`.
- 6 In the **Number of arguments** text field, type 1.

7 Find the **Functions** subsection. In the table, enter the following settings:

Function name	Position in file
C80_meas	1

8 Locate the **Interpolation and Extrapolation** section. From the **Interpolation** list, choose **Nearest neighbor**.

9 Locate the **Units** section. In the **Function** table, enter the following settings:

Function	Unit
C80_meas	dB

10 In the **Argument** table, enter the following settings:

Argument	Unit
Column 1	Hz

11 Locate the **Definition** section. Click  **Import**.

Interpolation 12 (int12)

1 In the **Home** toolbar, click  **Functions** and choose **Global>Interpolation**.

2 In the **Settings** window for **Interpolation**, locate the **Definition** section.

3 From the **Data source** list, choose **File**.

4 Click  **Browse**.

5 Browse to the model's Application Libraries folder and double-click the file chamber_music_hall_D50.txt.

6 In the **Number of arguments** text field, type 1.

7 Find the **Functions** subsection. In the table, enter the following settings:

Function name	Position in file
D50_meas	1

8 Locate the **Interpolation and Extrapolation** section. From the **Interpolation** list, choose **Nearest neighbor**.

9 Locate the **Units** section. In the **Function** table, enter the following settings:

Function	Unit
D50_meas	%

10 In the **Argument** table, enter the following settings:

Argument	Unit
Column 1	Hz

11 Locate the **Definition** section. Click  **Import**.

Now set up the ray acoustics simulation.

RAY ACOUSTICS (RAC)

- 1 In the **Model Builder** window, under **Component 1 (comp1)** click **Ray Acoustics (rac)**.
- 2 In the **Settings** window for **Ray Acoustics**, locate the **Intensity Computation** section.
- 3 From the **Intensity computation** list, choose **Compute power**.
- 4 Locate the **Material Properties of Exterior and Unmeshed Domains** section. In the c_{ext} text field, type c_0 .
- 5 In the ρ_{ext} text field, type ρ_0 .
- 6 In the α_{ext} text field, type $a_{\text{air}}(f_0)$.
- 7 Locate the **Additional Variables** section. Select the **Count reflections** check box.

Ray Properties 1

- 1 In the **Model Builder** window, expand the **Ray Acoustics (rac)** node, then click **Ray Properties 1**.
- 2 In the **Settings** window for **Ray Properties**, locate the **Ray Properties** section.
- 3 In the f text field, type f_0 .

Define the boundary conditions with the imported absorption and scattering coefficients.

Wall - Plaster

- 1 In the **Physics** toolbar, click  **Boundaries** and choose **Wall**.
- 2 In the **Settings** window for **Wall**, type **Wall - Plaster** in the **Label** text field.
- 3 Locate the **Boundary Selection** section. From the **Selection** list, choose **Plaster (all)**.
- 4 Locate the **Wall Condition** section. From the **Wall condition** list, choose **Mixed diffuse and specular reflection**.
- 5 In the γ_s text field, type $1 - s_{\text{plaster}}(f_0)$.
- 6 Locate the **Reflection Coefficients Model** section. In the α_s text field, type $a_{\text{plaster}}(f_0)$.
- 7 In the α_d text field, type $a_{\text{plaster}}(f_0)$.

Wall - Stage Panels

- 1 In the **Physics** toolbar, click  **Boundaries** and choose **Wall**.
- 2 In the **Settings** window for **Wall**, type Wall - Stage Panels in the **Label** text field.
- 3 Locate the **Boundary Selection** section. From the **Selection** list, choose **Stage panels**.
- 4 Locate the **Wall Condition** section. From the **Wall condition** list, choose **Mixed diffuse and specular reflection**.
- 5 In the γ_s text field, type 1-s_stagepanels(f0).
- 6 Locate the **Reflection Coefficients Model** section. In the α_s text field, type a_stagepanels(f0).
- 7 In the α_d text field, type a_stagepanels(f0).

Wall - Windows

- 1 In the **Physics** toolbar, click  **Boundaries** and choose **Wall**.
- 2 In the **Settings** window for **Wall**, type Wall - Windows in the **Label** text field.
- 3 Locate the **Boundary Selection** section. From the **Selection** list, choose **Windows**.
- 4 Locate the **Wall Condition** section. From the **Wall condition** list, choose **Mixed diffuse and specular reflection**.
- 5 In the γ_s text field, type 1-s_windows(f0).
- 6 Locate the **Reflection Coefficients Model** section. In the α_s text field, type a_windows(f0).
- 7 In the α_d text field, type a_windows(f0).

Wall - Seating

- 1 In the **Physics** toolbar, click  **Boundaries** and choose **Wall**.
- 2 In the **Settings** window for **Wall**, type Wall - Seating in the **Label** text field.
- 3 Locate the **Boundary Selection** section. From the **Selection** list, choose **Seating**.
- 4 Locate the **Wall Condition** section. From the **Wall condition** list, choose **Mixed diffuse and specular reflection**.
- 5 In the γ_s text field, type 1-s_seating(f0).
- 6 Locate the **Reflection Coefficients Model** section. In the α_s text field, type a_seating(f0).
- 7 In the α_d text field, type a_seating(f0).

Wall - Floor

- 1 In the **Physics** toolbar, click  **Boundaries** and choose **Wall**.

- 2 In the **Settings** window for **Wall**, type Wall - Floor in the **Label** text field.
- 3 Locate the **Boundary Selection** section. From the **Selection** list, choose **Floor**.
- 4 Locate the **Wall Condition** section. From the **Wall condition** list, choose **Mixed diffuse and specular reflection**.
- 5 In the γ_s text field, type 1-s_floor(f0).
- 6 Locate the **Reflection Coefficients Model** section. In the α_s text field, type a_floor(f0).
- 7 In the α_d text field, type a_floor(f0).

Wall - Ceiling

- 1 In the **Physics** toolbar, click  **Boundaries** and choose **Wall**.
- 2 In the **Settings** window for **Wall**, type Wall - Ceiling in the **Label** text field.
- 3 Locate the **Boundary Selection** section. From the **Selection** list, choose **Ceiling**.
- 4 Locate the **Wall Condition** section. From the **Wall condition** list, choose **Mixed diffuse and specular reflection**.
- 5 In the γ_s text field, type 1-s_ceiling(f0).
- 6 Locate the **Reflection Coefficients Model** section. In the α_s text field, type a_ceiling(f0).
- 7 In the α_d text field, type a_ceiling(f0).

Wall - Structured Plaster

- 1 In the **Physics** toolbar, click  **Boundaries** and choose **Wall**.
- 2 In the **Settings** window for **Wall**, type Wall - Structured Plaster in the **Label** text field.
- 3 Locate the **Boundary Selection** section. From the **Selection** list, choose **Structured plaster**.
- 4 Locate the **Wall Condition** section. From the **Wall condition** list, choose **Mixed diffuse and specular reflection**.
- 5 In the γ_s text field, type 1-s_structuredplaster(f0).
- 6 Locate the **Reflection Coefficients Model** section. In the α_s text field, type a_structuredplaster(f0).
- 7 In the α_d text field, type a_structuredplaster(f0).

Enter the source and ray properties.

Release from Grid - Source 1

- 1 In the **Physics** toolbar, click  **Global** and choose **Release from Grid**.

- 2 In the **Settings** window for **Release from Grid**, type Release from Grid - Source 1 in the **Label** text field.
- 3 Locate the **Initial Coordinates** section. In the $q_{x,0}$ text field, type x_{s1} .
- 4 In the $q_{y,0}$ text field, type y_{s1} .
- 5 In the $q_{z,0}$ text field, type z_{s1} .
- 6 Locate the **Ray Direction Vector** section. From the **Ray direction vector** list, choose **Spherical**.
- 7 In the N_w text field, type Nrays.
- 8 Locate the **Total Source Power** section. In the P_{src} text field, type P0.

Release from Grid - Source 2

- 1 In the **Physics** toolbar, click  **Global** and choose **Release from Grid**.
- 2 In the **Settings** window for **Release from Grid**, type Release from Grid - Source 2 in the **Label** text field.
- 3 Locate the **Initial Coordinates** section. In the $q_{x,0}$ text field, type x_{s2} .
- 4 In the $q_{y,0}$ text field, type y_{s2} .
- 5 In the $q_{z,0}$ text field, type z_{s2} .
- 6 Locate the **Ray Direction Vector** section. From the **Ray direction vector** list, choose **Spherical**.
- 7 In the N_w text field, type Nrays.
- 8 Locate the **Total Source Power** section. In the P_{src} text field, type P0.

Define the spatial and power termination criteria. The given expression for threshold power ensures consistent termination with regards to the source parameters.

Ray Termination 1

- 1 In the **Physics** toolbar, click  **Global** and choose **Ray Termination**.
- 2 In the **Settings** window for **Ray Termination**, locate the **Termination Criteria** section.
- 3 From the **Spatial extents of ray propagation** list, choose **Bounding box, from geometry**.
- 4 From the **Additional termination criteria** list, choose **Power**.
- 5 In the Q_{th} text field, type $P0/Nrays*1e-6$.

Now create the mesh. In ray tracing simulations for room acoustics, the mesh is only used to detect the collisions between rays and boundaries. Therefore, accuracy is not compromised with a coarse resolution.

MESH 1

- 1** In the **Model Builder** window, under **Component 1 (comp1)** click **Mesh 1**.
- 2** In the **Settings** window for **Mesh**, locate the **Sequence Type** section.
- 3** From the list, choose **User-controlled mesh**.

Size

- 1** In the **Model Builder** window, under **Component 1 (comp1)>Mesh 1** click **Size**.
- 2** In the **Settings** window for **Size**, locate the **Element Size** section.
- 3** From the **Predefined** list, choose **Coarser**.
- 4** Click to expand the **Element Size Parameters** section.

Free Triangular 1

- 1** In the **Model Builder** window, click **Free Triangular 1**.
- 2** In the **Settings** window for **Free Triangular**, locate the **Boundary Selection** section.
- 3** From the **Selection** list, choose **All boundaries**.

You can disregard the warning messages in the mesh. They are due to small surfaces in the imported geometry that do not affect the ray tracing.

4 Click  **Build All**.

The mesh should look like this.

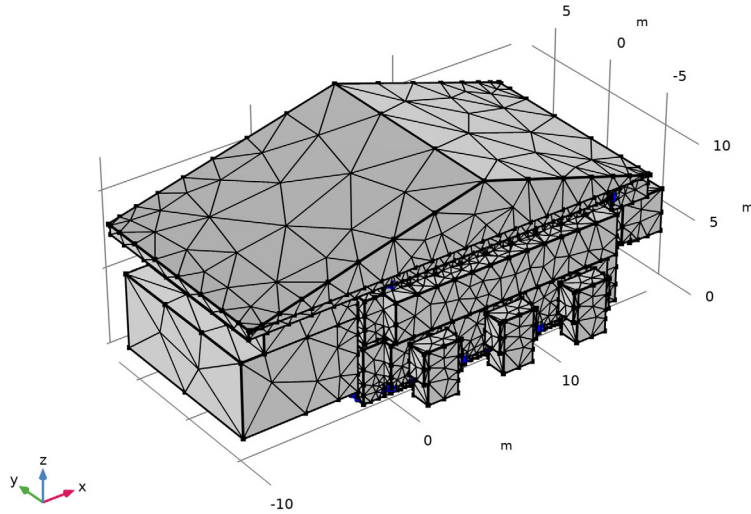

Create one study for each source position.

STUDY 1 - SOURCE 1

In the **Settings** window for **Study**, type Study 1 - Source 1 in the **Label** text field.

Parametric Sweep

- 1 In the **Study** toolbar, click  **Parametric Sweep**.
- 2 In the **Settings** window for **Parametric Sweep**, locate the **Study Settings** section.
- 3 Click **+ Add**.
- 4 In the table, click to select the cell at row number 1 and column number 2.
- 5 In the table, enter the following settings:

Parameter name	Parameter value list	Parameter unit
f0 (Band center frequency)		Hz

- 6 Click  **Range**.
- 7 In the **Range** dialog box, choose **ISO preferred frequencies** from the **Entry method** list.
- 8 In the **Start frequency** text field, type 100.

9 In the **Stop frequency** text field, type 5000.

10 From the **Interval** list, choose **1/3 octave**.

11 Click **Replace**.

Step 1: Ray Tracing

1 In the **Model Builder** window, click **Step 1: Ray Tracing**.

2 In the **Settings** window for **Ray Tracing**, locate the **Study Settings** section.

3 From the **Time unit** list, choose **s**.

4 In the **Output times** text field, type 0 2.

5 Locate the **Physics and Variables Selection** section. Select the **Modify model configuration for study step** check box.

6 In the tree, select **Component 1 (Comp1)>Ray Acoustics (Rac)>Release from Grid - Source 2**.

7 Right-click and choose **Disable**.

ADD STUDY

1 In the **Study** toolbar, click  **Add Study** to open the **Add Study** window.

2 Go to the **Add Study** window.

3 Find the **Studies** subsection. In the **Select Study** tree, select **Preset Studies for Selected Physics Interfaces>Ray Tracing**.

4 Click **Add Study** in the window toolbar.

5 In the **Study** toolbar, click  **Add Study** to close the **Add Study** window.

STUDY 2 - SOURCE 2

1 In the **Model Builder** window, click **Study 2**.

2 In the **Settings** window for **Study**, type Study 2 - Source 2 in the **Label** text field.

Parametric Sweep

1 In the **Study** toolbar, click  **Parametric Sweep**.

2 In the **Settings** window for **Parametric Sweep**, locate the **Study Settings** section.

3 Click **+ Add**.

4 In the table, click to select the cell at row number 1 and column number 2.

5 In the table, enter the following settings:

Parameter name	Parameter value list	Parameter unit
f0 (Band center frequency)		Hz

- 6 Click  **Range**.
- 7 In the **Range** dialog box, choose **ISO preferred frequencies** from the **Entry method** list.
- 8 In the **Start frequency** text field, type 100.
- 9 In the **Stop frequency** text field, type 5000.
- 10 From the **Interval** list, choose **1/3 octave**.
- 11 Click **Replace**.

Step 1: Ray Tracing

- 1 In the **Model Builder** window, click **Step 1: Ray Tracing**.
- 2 In the **Settings** window for **Ray Tracing**, locate the **Study Settings** section.
- 3 From the **Time unit** list, choose **s**.
- 4 In the **Output times** text field, type 0 2.
- 5 Locate the **Physics and Variables Selection** section. Select the **Modify model configuration for study step** check box.
- 6 In the tree, select **Component 1 (Comp1)>Ray Acoustics (Rac)>Release from Grid - Source 1**.
- 7 Click  **Disable**.

Make sure to select the following options to facilitate your workflow. All the results will be rendered after the model has solved. Rendering of all 10 impulse responses with 18 1/3-octave bands can take several hours depending on your hardware.

RESULTS

- 1 In the **Model Builder** window, click **Results**.
- 2 In the **Settings** window for **Results**, locate the **Update of Results** section.
- 3 Select the **Only plot when requested** check box.
- 4 Select the **Recompute all plot data after solving** check box.
- 5 Locate the **Save Data in the Model** section. From the **Save plot data** list, choose **On**.

The size of the saved file can be very large due to the many impulse responses calculated and stored. To save some disc space, set the saving preferences to optimize for file size.

- 6 From the **File** menu, choose **Preferences**.
- 7 In the **Preferences** dialog box, Click the **Files** tab.
- 8 Click the **Save** tab.
- 9 choose **File size** from the **Optimize for** list.
- 10 Click **OK**.

STUDY 1 - SOURCE 1

In the **Study** toolbar, click  **Compute**.

STUDY 2 - SOURCE 2

Click  **Compute**.

RESULTS

Ray Trajectories (rac) - Source 1

- 1 In the **Model Builder** window, under **Results** click **Ray Trajectories (rac)**.
- 2 In the **Settings** window for **3D Plot Group**, type Ray Trajectories (rac) - Source 1 in the **Label** text field.
- 3 Locate the **Data** section. From the **Time (s)** list, choose **Interpolation**.
- 4 In the **Time** text field, type 0.01.

Ray Trajectories 1

- 1 In the **Model Builder** window, expand the **Ray Trajectories (rac) - Source 1** node, then click **Ray Trajectories 1**.
- 2 In the **Settings** window for **Ray Trajectories**, locate the **Coloring and Style** section.
- 3 Find the **Line style** subsection. From the **Type** list, choose **None**.
- 4 Find the **Point style** subsection. From the **Type** list, choose **Point**.

Color Expression 1

- 1 In the **Model Builder** window, expand the **Ray Trajectories 1** node, then click **Color Expression 1**.
- 2 In the **Settings** window for **Color Expression**, locate the **Expression** section.
- 3 In the **Expression** text field, type rac.Q.

4 In the **Ray Trajectories (rac) - Source 1** toolbar, click  **Plot**.

f0(18)=5000 Hz Time=0.01 s

Ray trajectories

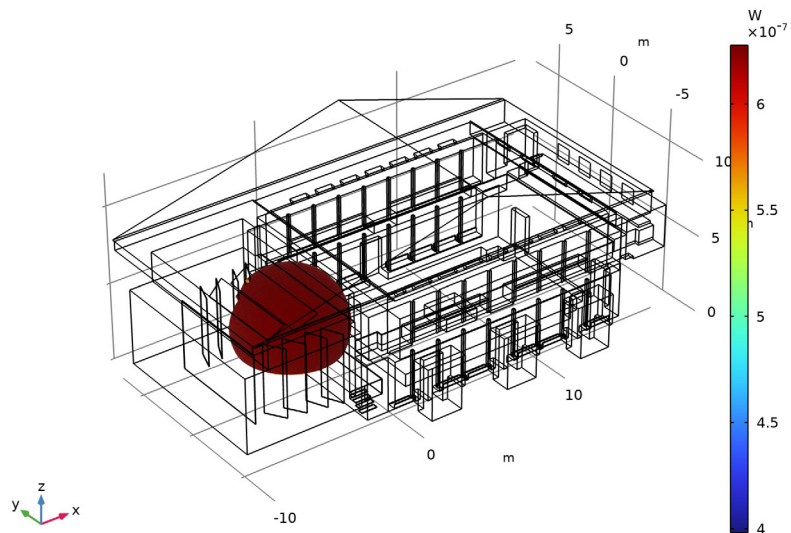

Ray Trajectories (rac) - Source 1

- 1 In the **Model Builder** window, under **Results** click **Ray Trajectories (rac) - Source 1**.
- 2 In the **Settings** window for **3D Plot Group**, locate the **Data** section.
- 3 In the **Time** text field, type 0.02.

4 In the **Ray Trajectories (rac) - Source 1** toolbar, click  **Plot**.

f0(18)=5000 Hz Time=0.02 s

Ray trajectories

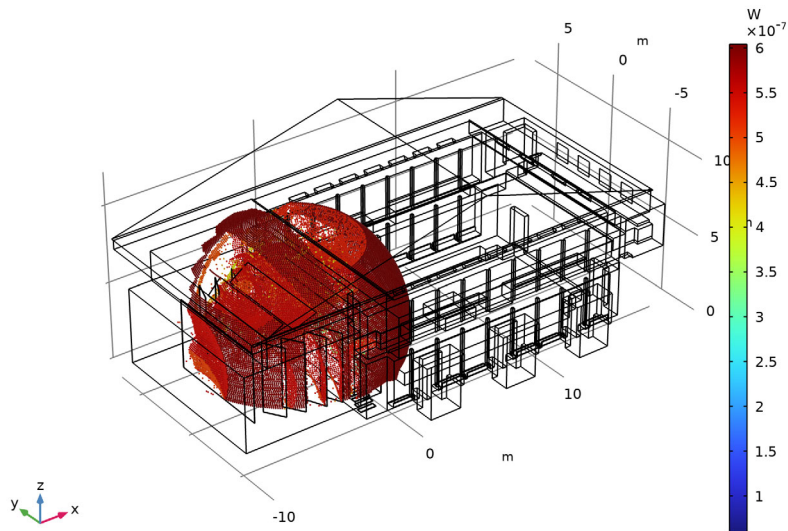

5 In the **Model Builder** window, click **Ray Trajectories (rac) - Source 1**.

6 In the **Time** text field, type 0.03.

7 In the **Ray Trajectories (rac) - Source 1** toolbar, click  **Plot**.

f0(18)=5000 Hz Time=0.03 s

Ray trajectories

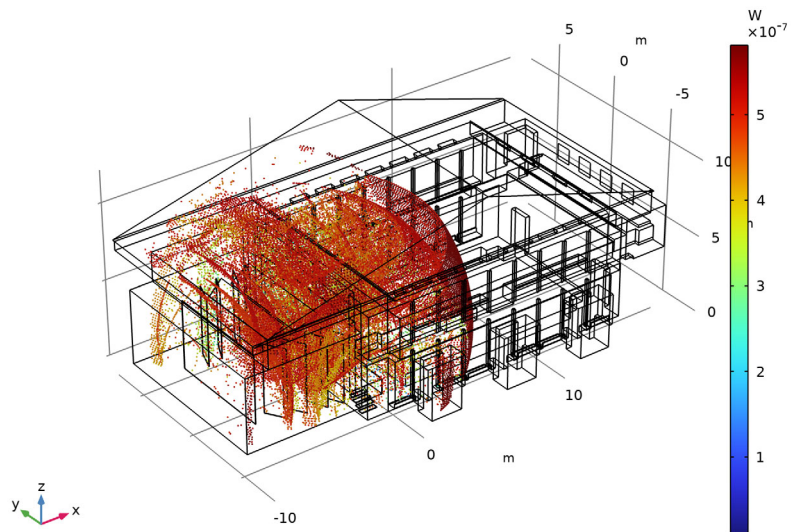

8 In the **Model Builder** window, click **Ray Trajectories (rac) - Source 1**.

9 In the **Time** text field, type 0.04.

10 In the **Ray Trajectories (rac) - Source 1** toolbar, click  **Plot**.

f0(18)=5000 Hz Time=0.04 s

Ray trajectories

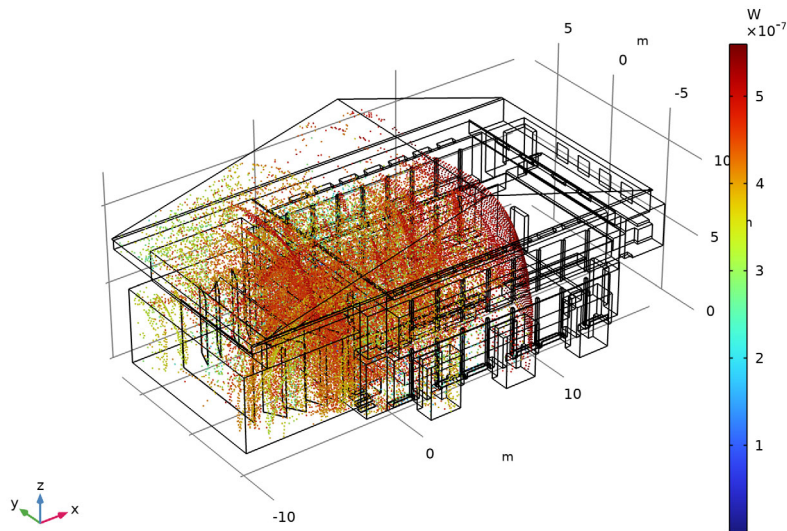

Ray Trajectories (rac) - Source 2

- 1 In the **Model Builder** window, under **Results** click **Ray Trajectories (rac) 1**.
- 2 In the **Settings** window for **3D Plot Group**, type Ray Trajectories (rac) - Source 2 in the **Label** text field.
- 3 Locate the **Data** section. From the **Time (s)** list, choose **Interpolation**.
- 4 In the **Time** text field, type 0.01.

Ray Trajectories 1

- 1 In the **Model Builder** window, expand the **Ray Trajectories (rac) - Source 2** node, then click **Ray Trajectories 1**.
- 2 In the **Settings** window for **Ray Trajectories**, locate the **Coloring and Style** section.
- 3 Find the **Line style** subsection. From the **Type** list, choose **None**.
- 4 Find the **Point style** subsection. From the **Type** list, choose **Point**.

Color Expression 1

- 1 In the **Model Builder** window, expand the **Ray Trajectories 1** node, then click **Color Expression 1**.
- 2 In the **Settings** window for **Color Expression**, locate the **Expression** section.

3 In the **Expression** text field, type $rac.Q$.

4 In the **Ray Trajectories (rac) - Source 2** toolbar, click  **Plot**.

Next set up the datasets corresponding to the 10 source-receiver pairs.

Receiver 3D 1_1

1 In the **Results** toolbar, click  **More Datasets** and choose **Receiver 3D**.

2 In the **Settings** window for **Receiver 3D**, type Receiver 3D 1_1 in the **Label** text field.

3 Locate the **Receiver** section. Find the **Center** subsection. In the **x** text field, type x_{r1} .

4 In the **y** text field, type y_{r1} .

5 In the **z** text field, type z_{r1} .

6 Find the **Radius** subsection. From the **Radius input** list, choose **User defined**.

7 In the **Radius** text field, type r_{rec} .

Receiver 3D 1_2

1 In the **Results** toolbar, click  **More Datasets** and choose **Receiver 3D**.

2 In the **Settings** window for **Receiver 3D**, type Receiver 3D 1_2 in the **Label** text field.

3 Locate the **Receiver** section. Find the **Center** subsection. In the **x** text field, type x_{r2} .

4 In the **y** text field, type y_{r2} .

5 In the **z** text field, type z_{r2} .

6 Find the **Radius** subsection. From the **Radius input** list, choose **User defined**.

7 In the **Radius** text field, type r_{rec} .

Receiver 3D 1_3

1 In the **Results** toolbar, click  **More Datasets** and choose **Receiver 3D**.

2 In the **Settings** window for **Receiver 3D**, type Receiver 3D 1_3 in the **Label** text field.

3 Locate the **Receiver** section. Find the **Center** subsection. In the **x** text field, type x_{r3} .

4 In the **y** text field, type y_{r3} .

5 In the **z** text field, type z_{r3} .

6 Find the **Radius** subsection. From the **Radius input** list, choose **User defined**.

7 In the **Radius** text field, type r_{rec} .

Receiver 3D 1_4

1 In the **Results** toolbar, click  **More Datasets** and choose **Receiver 3D**.

2 In the **Settings** window for **Receiver 3D**, type Receiver 3D 1_4 in the **Label** text field.

3 Locate the **Receiver** section. Find the **Center** subsection. In the **x** text field, type x_{r4} .

- 4 In the **y** text field, type `y_r4`.
- 5 In the **z** text field, type `z_r4`.
- 6 Find the **Radius** subsection. From the **Radius input** list, choose **User defined**.
- 7 In the **Radius** text field, type `r_rec`.

Receiver 3D 1_5

- 1 In the **Results** toolbar, click  **More Datasets** and choose **Receiver 3D**.
- 2 In the **Settings** window for **Receiver 3D**, type `Receiver 3D 1_5` in the **Label** text field.
- 3 Locate the **Receiver** section. Find the **Center** subsection. In the **x** text field, type `x_r5`.
- 4 In the **y** text field, type `y_r5`.
- 5 In the **z** text field, type `z_r5`.
- 6 Find the **Radius** subsection. From the **Radius input** list, choose **User defined**.
- 7 In the **Radius** text field, type `r_rec`.

Receiver 3D 2_1

- 1 In the **Results** toolbar, click  **More Datasets** and choose **Receiver 3D**.
- 2 In the **Settings** window for **Receiver 3D**, type `Receiver 3D 2_1` in the **Label** text field.
- 3 Locate the **Data** section. From the **Dataset** list, choose **Ray 2**.
- 4 Locate the **Receiver** section. Find the **Center** subsection. In the **x** text field, type `x_r1`.
- 5 In the **y** text field, type `y_r1`.
- 6 In the **z** text field, type `z_r1`.
- 7 Find the **Radius** subsection. From the **Radius input** list, choose **User defined**.
- 8 In the **Radius** text field, type `r_rec`.

Receiver 3D 2_2

- 1 In the **Results** toolbar, click  **More Datasets** and choose **Receiver 3D**.
- 2 In the **Settings** window for **Receiver 3D**, type `Receiver 3D 2_2` in the **Label** text field.
- 3 Locate the **Data** section. From the **Dataset** list, choose **Ray 2**.
- 4 Locate the **Receiver** section. Find the **Center** subsection. In the **x** text field, type `x_r2`.
- 5 In the **y** text field, type `y_r2`.
- 6 In the **z** text field, type `z_r2`.
- 7 Find the **Radius** subsection. From the **Radius input** list, choose **User defined**.
- 8 In the **Radius** text field, type `r_rec`.

Receiver 3D 2_3

- 1 In the **Results** toolbar, click  **More Datasets** and choose **Receiver 3D**.
- 2 In the **Settings** window for **Receiver 3D**, type Receiver 3D 2_3 in the **Label** text field.
- 3 Locate the **Data** section. From the **Dataset** list, choose **Ray 2**.
- 4 Locate the **Receiver** section. Find the **Center** subsection. In the **x** text field, type x_r3.
- 5 In the **y** text field, type y_r3.
- 6 In the **z** text field, type z_r3.
- 7 Find the **Radius** subsection. From the **Radius input** list, choose **User defined**.
- 8 In the **Radius** text field, type r_rec.

Receiver 3D 2_4

- 1 In the **Results** toolbar, click  **More Datasets** and choose **Receiver 3D**.
- 2 In the **Settings** window for **Receiver 3D**, type Receiver 3D 2_4 in the **Label** text field.
- 3 Locate the **Data** section. From the **Dataset** list, choose **Ray 2**.
- 4 Locate the **Receiver** section. Find the **Center** subsection. In the **x** text field, type x_r4.
- 5 In the **y** text field, type y_r4.
- 6 In the **z** text field, type z_r4.
- 7 Find the **Radius** subsection. From the **Radius input** list, choose **User defined**.
- 8 In the **Radius** text field, type r_rec.

Receiver 3D 2_5

- 1 In the **Results** toolbar, click  **More Datasets** and choose **Receiver 3D**.
- 2 In the **Settings** window for **Receiver 3D**, type Receiver 3D 2_5 in the **Label** text field.
- 3 Locate the **Data** section. From the **Dataset** list, choose **Ray 2**.
- 4 Locate the **Receiver** section. Find the **Center** subsection. In the **x** text field, type x_r5.
- 5 In the **y** text field, type y_r5.
- 6 In the **z** text field, type z_r5.
- 7 Find the **Radius** subsection. From the **Radius input** list, choose **User defined**.
- 8 In the **Radius** text field, type r_rec.

Set up the impulse responses corresponding to the datasets previously created, plot the level decay curves using the **Energy Decay** subfeature, and compute the desired room acoustic parameters.

Impulse response I_1

- 1 In the **Results** toolbar, click  **ID Plot Group**.

- 2 In the **Settings** window for **ID Plot Group**, type **Impulse response 1_1** in the **Label** text field.
- 3 Locate the **Data** section. From the **Dataset** list, choose **Receiver 3D I_1**.
- 4 Locate the **Legend** section. From the **Position** list, choose **Lower left**.

Impulse Response I

- 1 In the **Impulse response I_1** toolbar, click  **More Plots** and choose **Impulse Response**.
- 2 In the **Settings** window for **Impulse Response**, locate the **Data** section.
- 3 From the **Frequency interpretation** list, choose **1/3 octave**.
- 4 Click to expand the **Legends** section. Select the **Show legends** check box.

Energy Decay I

- 1 Right-click **Impulse Response I** and choose **Energy Decay**.
- 2 In the **Settings** window for **Energy Decay**, locate the **Display** section.
- 3 From the **Band type** list, choose **Individual bands**.
- 4 From the **Plot** list, choose **Level decay**.
- 5 Locate the **Table** section. Find the **Early energy** subsection. Clear the **C₅₀**, **Clarity** check box.
- 6 Clear the **t_r**, **First ray arrival time** check box.
- 7 Clear the **t_s**, **Center time** check box.
- 8 Find the **Reverberation** subsection. Clear the **T₃₀** check box.
- 9 Clear the **T₆₀** check box.
- 10 Find the **Speech intelligibility** subsection. Clear the **SNR**, **Apparent SNR** check box.
- 11 Clear the **STI**, **Speech transmission index** check box.
- 12 In the **Impulse response I_1** toolbar, click  **Plot**.
- 13 Locate the **Display** section. From the **Band frequency** list, choose **All frequencies**.

14 In the **Impulse response I_1** toolbar, click  **Plot**.

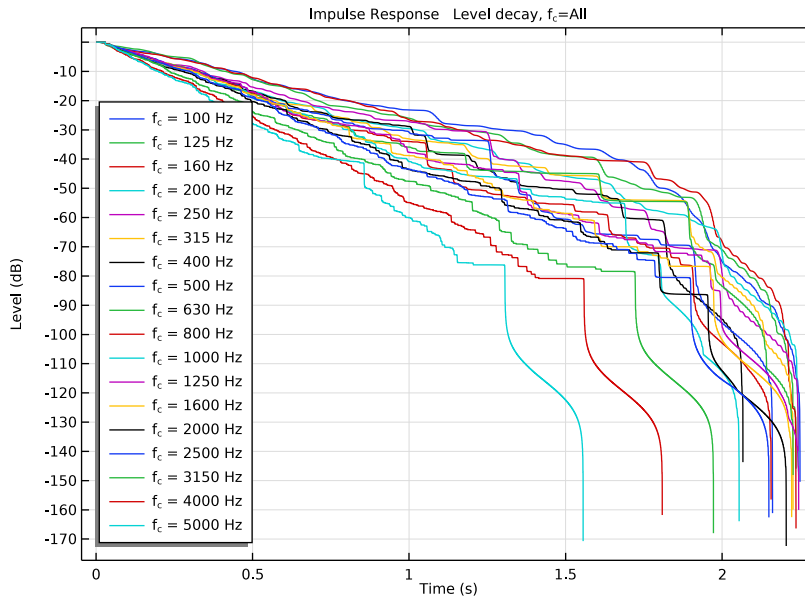

Impulse response I_2



- 1 In the **Home** toolbar, click  **Add Plot Group** and choose **ID Plot Group**.
- 2 In the **Settings** window for **ID Plot Group**, type **Impulse response 1_2** in the **Label** text field.
- 3 Locate the **Data** section. From the **Dataset** list, choose **Receiver 3D I_2**.
- 4 Locate the **Legend** section. From the **Position** list, choose **Lower left**.

Impulse Response I

- 1 In the **Impulse response I_2** toolbar, click  **More Plots** and choose **Impulse Response**.
- 2 In the **Settings** window for **Impulse Response**, locate the **Data** section.
- 3 From the **Frequency interpretation** list, choose **1/3 octave**.
- 4 Click to expand the **Legends** section. Select the **Show legends** check box.

Energy Decay I

- 1 Right-click **Impulse Response I** and choose **Energy Decay**.
- 2 In the **Settings** window for **Energy Decay**, locate the **Display** section.
- 3 From the **Band type** list, choose **Individual bands**.
- 4 From the **Plot** list, choose **Level decay**.

- 5 Locate the **Table** section. Find the **Early energy** subsection. Clear the **C₅₀, Clarity** check box.
- 6 Clear the **t_r, First ray arrival time** check box.
- 7 Clear the **t_s, Center time** check box.
- 8 Find the **Reverberation** subsection. Clear the **T₃₀** check box.
- 9 Clear the **T₆₀** check box.
- 10 Find the **Speech intelligibility** subsection. Clear the **SNR, Apparent SNR** check box.
- 11 Clear the **STI, Speech transmission index** check box.
- 12 In the **Impulse response 1_2** toolbar, click  **Plot**.
- 13 Locate the **Display** section. From the **Band frequency** list, choose **All frequencies**.
- 14 In the **Impulse response 1_2** toolbar, click  **Plot**.

Impulse response 1_3



- 1 In the **Home** toolbar, click  **Add Plot Group** and choose **ID Plot Group**.
- 2 In the **Settings** window for **ID Plot Group**, type **Impulse response 1_3** in the **Label** text field.
- 3 Locate the **Data** section. From the **Dataset** list, choose **Receiver 3D 1_3**.
- 4 Locate the **Legend** section. From the **Position** list, choose **Lower left**.

Impulse Response 1

- 1 In the **Impulse response 1_3** toolbar, click  **More Plots** and choose **Impulse Response**.
- 2 In the **Settings** window for **Impulse Response**, locate the **Data** section.
- 3 From the **Frequency interpretation** list, choose **1/3 octave**.
- 4 Click to expand the **Legends** section. Select the **Show legends** check box.

Energy Decay 1

- 1 Right-click **Impulse Response 1** and choose **Energy Decay**.
- 2 In the **Settings** window for **Energy Decay**, locate the **Display** section.
- 3 From the **Band type** list, choose **Individual bands**.
- 4 From the **Plot** list, choose **Level decay**.
- 5 Locate the **Table** section. Find the **Early energy** subsection. Clear the **C₅₀, Clarity** check box.
- 6 Clear the **t_r, First ray arrival time** check box.
- 7 Clear the **t_s, Center time** check box.
- 8 Find the **Reverberation** subsection. Clear the **T₃₀** check box.

- 9 Clear the T_{60} check box.
- 10 Find the **Speech intelligibility** subsection. Clear the **SNR, Apparent SNR** check box.
- 11 Clear the **STI, Speech transmission index** check box.
- 12 In the **Impulse response I_3** toolbar, click  **Plot**.
- 13 Locate the **Display** section. From the **Band frequency** list, choose **All frequencies**.
- 14 In the **Impulse response I_3** toolbar, click  **Plot**.

Impulse response I_4

- 1 In the **Home** toolbar, click  **Add Plot Group** and choose **ID Plot Group**.
- 2 In the **Settings** window for **ID Plot Group**, type Impulse response 1_4 in the **Label** text field.
- 3 Locate the **Data** section. From the **Dataset** list, choose **Receiver 3D I_4**.
- 4 Locate the **Legend** section. From the **Position** list, choose **Lower left**.

Impulse Response I

- 1 In the **Impulse response I_4** toolbar, click  **More Plots** and choose **Impulse Response**.
- 2 In the **Settings** window for **Impulse Response**, locate the **Data** section.
- 3 From the **Frequency interpretation** list, choose **1/3 octave**.
- 4 Click to expand the **Legends** section. Select the **Show legends** check box.

Energy Decay I

- 1 Right-click **Impulse Response I** and choose **Energy Decay**.
- 2 In the **Settings** window for **Energy Decay**, locate the **Display** section.
- 3 From the **Band type** list, choose **Individual bands**.
- 4 From the **Plot** list, choose **Level decay**.
- 5 Locate the **Table** section. Find the **Early energy** subsection. Clear the C_{50} , **Clarity** check box.
- 6 Clear the t_r , **First ray arrival time** check box.
- 7 Clear the t_s , **Center time** check box.
- 8 Find the **Reverberation** subsection. Clear the T_{30} check box.
- 9 Clear the T_{60} check box.
- 10 Find the **Speech intelligibility** subsection. Clear the **SNR, Apparent SNR** check box.
- 11 Clear the **STI, Speech transmission index** check box.
- 12 In the **Impulse response I_4** toolbar, click  **Plot**.

13 Locate the **Display** section. From the **Band frequency** list, choose **All frequencies**.

14 In the **Impulse response 1_4** toolbar, click  **Plot**.

Impulse response 1_5

1 In the **Home** toolbar, click  **Add Plot Group** and choose **ID Plot Group**.

2 In the **Settings** window for **ID Plot Group**, type Impulse response 1_5 in the **Label** text field.

3 Locate the **Data** section. From the **Dataset** list, choose **Receiver 3D 1_5**.

4 Locate the **Legend** section. From the **Position** list, choose **Lower left**.

Impulse Response 1

1 In the **Impulse response 1_5** toolbar, click  **More Plots** and choose **Impulse Response**.

2 In the **Settings** window for **Impulse Response**, locate the **Data** section.

3 From the **Frequency interpretation** list, choose **1/3 octave**.

4 Click to expand the **Legends** section. Select the **Show legends** check box.

Energy Decay 1

1 Right-click **Impulse Response 1** and choose **Energy Decay**.

2 In the **Settings** window for **Energy Decay**, locate the **Display** section.

3 From the **Band type** list, choose **Individual bands**.

4 From the **Plot** list, choose **Level decay**.

5 Locate the **Table** section. Find the **Early energy** subsection. Clear the **C₅₀**, **Clarity** check box.

6 Clear the **t_r**, **First ray arrival time** check box.

7 Clear the **t_s**, **Center time** check box.

8 Find the **Reverberation** subsection. Clear the **T₃₀** check box.

9 Clear the **T₆₀** check box.

10 Find the **Speech intelligibility** subsection. Clear the **SNR, Apparent SNR** check box.

11 Clear the **STI, Speech transmission index** check box.

12 In the **Impulse response 1_5** toolbar, click  **Plot**.

13 Locate the **Display** section. From the **Band frequency** list, choose **All frequencies**.

14 In the **Impulse response 1_5** toolbar, click  **Plot**.

Impulse response 2_1



1 In the **Home** toolbar, click  **Add Plot Group** and choose **ID Plot Group**.

- 2 In the **Settings** window for **ID Plot Group**, type **Impulse response 2_1** in the **Label** text field.
- 3 Locate the **Data** section. From the **Dataset** list, choose **Receiver 3D 2_1**.
- 4 Locate the **Legend** section. From the **Position** list, choose **Lower left**.

Impulse Response 1

- 1 In the **Impulse response 2_1** toolbar, click  **More Plots** and choose **Impulse Response**.
- 2 In the **Settings** window for **Impulse Response**, locate the **Data** section.
- 3 From the **Frequency interpretation** list, choose **1/3 octave**.
- 4 Click to expand the **Legends** section. Select the **Show legends** check box.

Energy Decay 1

- 1 Right-click **Impulse Response 1** and choose **Energy Decay**.
- 2 In the **Settings** window for **Energy Decay**, locate the **Display** section.
- 3 From the **Band type** list, choose **Individual bands**.
- 4 From the **Plot** list, choose **Level decay**.
- 5 Locate the **Table** section. Find the **Early energy** subsection. Clear the **C₅₀, Clarity** check box.
- 6 Clear the **t_r, First ray arrival time** check box.
- 7 Clear the **t_s, Center time** check box.
- 8 Find the **Reverberation** subsection. Clear the **T₃₀** check box.
- 9 Clear the **T₆₀** check box.
- 10 Find the **Speech intelligibility** subsection. Clear the **SNR, Apparent SNR** check box.
- 11 Clear the **STI, Speech transmission index** check box.
- 12 In the **Impulse response 2_1** toolbar, click  **Plot**.
- 13 Locate the **Display** section. From the **Band frequency** list, choose **All frequencies**.
- 14 In the **Impulse response 2_1** toolbar, click  **Plot**.



Impulse response 2_2

- 1 In the **Home** toolbar, click  **Add Plot Group** and choose **ID Plot Group**.
- 2 In the **Settings** window for **ID Plot Group**, type **Impulse response 2_2** in the **Label** text field.
- 3 Locate the **Data** section. From the **Dataset** list, choose **Receiver 3D 2_2**.
- 4 Locate the **Legend** section. From the **Position** list, choose **Lower left**.

Impulse Response 1

- 1 In the **Impulse response 2_2** toolbar, click  **More Plots** and choose **Impulse Response**.
- 2 In the **Settings** window for **Impulse Response**, locate the **Data** section.
- 3 From the **Frequency interpretation** list, choose **1/3 octave**.
- 4 Click to expand the **Legends** section. Select the **Show legends** check box.

Energy Decay 1

- 1 Right-click **Impulse Response 1** and choose **Energy Decay**.
- 2 In the **Settings** window for **Energy Decay**, locate the **Display** section.
- 3 From the **Band type** list, choose **Individual bands**.
- 4 From the **Plot** list, choose **Level decay**.
- 5 Locate the **Table** section. Find the **Early energy** subsection. Clear the **C₅₀**, **Clarity** check box.
- 6 Clear the **t_r**, **First ray arrival time** check box.
- 7 Clear the **t_s**, **Center time** check box.
- 8 Find the **Reverberation** subsection. Clear the **T₃₀** check box.
- 9 Clear the **T₆₀** check box.
- 10 Find the **Speech intelligibility** subsection. Clear the **SNR**, **Apparent SNR** check box.
- 11 Clear the **STI**, **Speech transmission index** check box.
- 12 In the **Impulse response 2_2** toolbar, click  **Plot**.
- 13 Locate the **Display** section. From the **Band frequency** list, choose **All frequencies**.
- 14 In the **Impulse response 2_2** toolbar, click  **Plot**.



Impulse response 2_3

- 1 In the **Home** toolbar, click  **Add Plot Group** and choose **ID Plot Group**.
- 2 In the **Settings** window for **ID Plot Group**, type **Impulse response 2_3** in the **Label** text field.
- 3 Locate the **Data** section. From the **Dataset** list, choose **Receiver 3D 2_3**.
- 4 Locate the **Legend** section. From the **Position** list, choose **Lower left**.

Impulse Response 1

- 1 In the **Impulse response 2_3** toolbar, click  **More Plots** and choose **Impulse Response**.
- 2 In the **Settings** window for **Impulse Response**, locate the **Data** section.
- 3 From the **Frequency interpretation** list, choose **1/3 octave**.
- 4 Click to expand the **Legends** section. Select the **Show legends** check box.

Energy Decay I

- 1 Right-click **Impulse Response I** and choose **Energy Decay**.
- 2 In the **Settings** window for **Energy Decay**, locate the **Display** section.
- 3 From the **Band type** list, choose **Individual bands**.
- 4 From the **Plot** list, choose **Level decay**.
- 5 Locate the **Table** section. Find the **Early energy** subsection. Clear the **C₅₀**, **Clarity** check box.
- 6 Clear the **t_r**, **First ray arrival time** check box.
- 7 Clear the **t_s**, **Center time** check box.
- 8 Find the **Reverberation** subsection. Clear the **T₃₀** check box.
- 9 Clear the **T₆₀** check box.
- 10 Find the **Speech intelligibility** subsection. Clear the **SNR**, **Apparent SNR** check box.
- 11 Clear the **STI**, **Speech transmission index** check box.
- 12 In the **Impulse response 2_3** toolbar, click  **Plot**.
- 13 Locate the **Display** section. From the **Band frequency** list, choose **All frequencies**.
- 14 In the **Impulse response 2_3** toolbar, click  **Plot**.

Impulse response 2_4



- 1 In the **Home** toolbar, click  **Add Plot Group** and choose **ID Plot Group**.
- 2 In the **Settings** window for **ID Plot Group**, type Impulse response 2_4 in the **Label** text field.
- 3 Locate the **Data** section. From the **Dataset** list, choose **Receiver 3D 2_4**.
- 4 Locate the **Legend** section. From the **Position** list, choose **Lower left**.

Impulse Response I

- 1 In the **Impulse response 2_4** toolbar, click  **More Plots** and choose **Impulse Response**.
- 2 In the **Settings** window for **Impulse Response**, locate the **Data** section.
- 3 From the **Frequency interpretation** list, choose **1/3 octave**.
- 4 Click to expand the **Legends** section. Select the **Show legends** check box.

Energy Decay I

- 1 Right-click **Impulse Response I** and choose **Energy Decay**.
- 2 In the **Settings** window for **Energy Decay**, locate the **Display** section.
- 3 From the **Band type** list, choose **Individual bands**.
- 4 From the **Plot** list, choose **Level decay**.

- 5 Locate the **Table** section. Find the **Early energy** subsection. Clear the **C₅₀, Clarity** check box.
- 6 Clear the **t_r, First ray arrival time** check box.
- 7 Clear the **t_s, Center time** check box.
- 8 Find the **Reverberation** subsection. Clear the **T₃₀** check box.
- 9 Clear the **T₆₀** check box.
- 10 Find the **Speech intelligibility** subsection. Clear the **SNR, Apparent SNR** check box.
- 11 Clear the **STI, Speech transmission index** check box.
- 12 In the **Impulse response 2_4** toolbar, click  **Plot**.
- 13 Locate the **Display** section. From the **Band frequency** list, choose **All frequencies**.
- 14 In the **Impulse response 2_4** toolbar, click  **Plot**.

Impulse response 2_5



- 1 In the **Home** toolbar, click  **Add Plot Group** and choose **ID Plot Group**.
- 2 In the **Settings** window for **ID Plot Group**, type **Impulse response 2_5** in the **Label** text field.
- 3 Locate the **Data** section. From the **Dataset** list, choose **Receiver 3D 2_5**.
- 4 Locate the **Legend** section. From the **Position** list, choose **Lower left**.

Impulse Response 1

- 1 In the **Impulse response 2_5** toolbar, click  **More Plots** and choose **Impulse Response**.
- 2 In the **Settings** window for **Impulse Response**, locate the **Data** section.
- 3 From the **Frequency interpretation** list, choose **1/3 octave**.
- 4 Click to expand the **Legends** section. Select the **Show legends** check box.

Energy Decay 1

- 1 Right-click **Impulse Response 1** and choose **Energy Decay**.
- 2 In the **Settings** window for **Energy Decay**, locate the **Display** section.
- 3 From the **Band type** list, choose **Individual bands**.
- 4 From the **Plot** list, choose **Level decay**.
- 5 Locate the **Table** section. Find the **Early energy** subsection. Clear the **C₅₀, Clarity** check box.
- 6 Clear the **t_r, First ray arrival time** check box.
- 7 Clear the **t_s, Center time** check box.
- 8 Find the **Reverberation** subsection. Clear the **T₃₀** check box.

- 9 Clear the **T₆₀** check box.
- 10 Find the **Speech intelligibility** subsection. Clear the **SNR, Apparent SNR** check box.
- 11 Clear the **STI, Speech transmission index** check box.
- 12 In the **Impulse response 2_5** toolbar, click  **Plot**.
- 13 Locate the **Display** section. From the **Band frequency** list, choose **All frequencies**.
- 14 In the **Impulse response 2_5** toolbar, click  **Plot**.

Impulse response 1_1, Impulse response 1_2, Impulse response 1_3, Impulse response 1_4, Impulse response 1_5, Impulse response 2_1, Impulse response 2_2, Impulse response 2_3, Impulse response 2_4, Impulse response 2_5

- 1 In the **Model Builder** window, under **Results**, Ctrl-click to select **Impulse response 1_1, Impulse response 1_2, Impulse response 1_3, Impulse response 1_4, Impulse response 1_5, Impulse response 2_1, Impulse response 2_2, Impulse response 2_3, Impulse response 2_4, and Impulse response 2_5**.
- 2 Right-click and choose **Group**.

Rename the result tables to match with their corresponding impulse responses.

Impulse responses

In the **Settings** window for **Group**, type Impulse responses in the **Label** text field.

Objective Quality Metrics 1_1

- 1 In the **Model Builder** window, expand the **Results>Tables** node, then click **Objective Quality Metrics**.
- 2 In the **Settings** window for **Table**, type Objective Quality Metrics 1_1 in the **Label** text field.

Objective Quality Metrics 1_2

- 1 In the **Model Builder** window, click **Objective Quality Metrics 1**.
- 2 In the **Settings** window for **Table**, type Objective Quality Metrics 1_2 in the **Label** text field.

Objective Quality Metrics 1_3

- 1 In the **Model Builder** window, under **Results>Tables** click **Objective Quality Metrics 2**.
- 2 In the **Settings** window for **Table**, type Objective Quality Metrics 1_3 in the **Label** text field.

Objective Quality Metrics 1_4

- 1 In the **Model Builder** window, under **Results>Tables** click **Objective Quality Metrics 3**.

- 2 In the **Settings** window for **Table**, type Objective Quality Metrics 1_4 in the **Label** text field.

Objective Quality Metrics 1_5

- 1 In the **Model Builder** window, under **Results>Tables** click **Objective Quality Metrics 4**.
- 2 In the **Settings** window for **Table**, type Objective Quality Metrics 1_5 in the **Label** text field.

Objective Quality Metrics 2_1

- 1 In the **Model Builder** window, under **Results>Tables** click **Objective Quality Metrics 5**.
- 2 In the **Settings** window for **Table**, type Objective Quality Metrics 2_1 in the **Label** text field.

Objective Quality Metrics 2_2

- 1 In the **Model Builder** window, under **Results>Tables** click **Objective Quality Metrics 6**.
- 2 In the **Settings** window for **Table**, type Objective Quality Metrics 2_2 in the **Label** text field.

Objective Quality Metrics 2_3

- 1 In the **Model Builder** window, under **Results>Tables** click **Objective Quality Metrics 7**.
- 2 In the **Settings** window for **Table**, type Objective Quality Metrics 2_3 in the **Label** text field.

Objective Quality Metrics 2_4

- 1 In the **Model Builder** window, under **Results>Tables** click **Objective Quality Metrics 8**.
- 2 In the **Settings** window for **Table**, type Objective Quality Metrics 2_4 in the **Label** text field.

Objective Quality Metrics 2_5

- 1 In the **Model Builder** window, under **Results>Tables** click **Objective Quality Metrics 9**.
- 2 In the **Settings** window for **Table**, type Objective Quality Metrics 2_5 in the **Label** text field.

Now that the impulse responses of the different source-receiver pairs have been computed, interpolate the resulting acoustic parameters for post-processing.

GLOBAL DEFINITIONS

Interpolation 13 (int13)

- 1 In the **Home** toolbar, click $f(\infty)$ **Functions** and choose **Global>Interpolation**.
- 2 In the **Settings** window for **Interpolation**, locate the **Definition** section.

3 From the **Data source** list, choose **Result table**.

4 Find the **Functions** subsection. In the table, enter the following settings:

Function name	Position in file
D50_11	1
C80_11	2
EDT_11	3
T20_11	4

5 Locate the **Interpolation and Extrapolation** section. From the **Interpolation** list, choose **Nearest neighbor**.

6 Locate the **Units** section. In the **Function** table, enter the following settings:

Function	Unit
D50_11	%
C80_11	dB
EDT_11	s
T20_11	s

7 In the **Argument** table, enter the following settings:

Argument	Unit
Column 1	Hz

Interpolation 14 (int14)

1 In the **Home** toolbar, click  **Functions** and choose **Global>Interpolation**.

2 In the **Settings** window for **Interpolation**, locate the **Definition** section.

3 From the **Data source** list, choose **Result table**.

4 From the **Table from** list, choose **Objective Quality Metrics 1_2**.

5 Find the **Functions** subsection. In the table, enter the following settings:

Function name	Position in file
D50_12	1
C80_12	2
EDT_12	3
T20_12	4

6 Locate the **Interpolation and Extrapolation** section. From the **Interpolation** list, choose **Nearest neighbor**.

7 Locate the **Units** section. In the **Function** table, enter the following settings:

Function	Unit
D50_12	%
C80_12	dB
EDT_12	s
T20_12	s

8 In the **Argument** table, enter the following settings:

Argument	Unit
Column 1	Hz

Interpolation 15 (int15)

1 In the **Home** toolbar, click **f(x) Functions** and choose **Global>Interpolation**.

2 In the **Settings** window for **Interpolation**, locate the **Definition** section.

3 From the **Data source** list, choose **Result table**.

4 From the **Table from** list, choose **Objective Quality Metrics 1_3**.

5 Find the **Functions** subsection. In the table, enter the following settings:

Function name	Position in file
D50_13	1
C80_13	2
EDT_13	3
T20_13	4

6 Locate the **Interpolation and Extrapolation** section. From the **Interpolation** list, choose **Nearest neighbor**.

7 Locate the **Units** section. In the **Function** table, enter the following settings:

Function	Unit
D50_13	%
C80_13	dB
EDT_13	s
T20_13	s

8 In the **Argument** table, enter the following settings:

Argument	Unit
Column 1	Hz

Interpolation 16 (int16)

- 1 In the **Home** toolbar, click **f(x) Functions** and choose **Global>Interpolation**.
- 2 In the **Settings** window for **Interpolation**, locate the **Definition** section.
- 3 From the **Data source** list, choose **Result table**.
- 4 From the **Table from** list, choose **Objective Quality Metrics 1_4**.
- 5 Find the **Functions** subsection. In the table, enter the following settings:

Function name	Position in file
D50_14	1
C80_14	2
EDT_14	3
T20_14	4

- 6 Locate the **Interpolation and Extrapolation** section. From the **Interpolation** list, choose **Nearest neighbor**.
- 7 Locate the **Units** section. In the **Function** table, enter the following settings:

Function	Unit
D50_14	%
C80_14	dB
EDT_14	s
T20_14	s

8 In the **Argument** table, enter the following settings:

Argument	Unit
Column 1	Hz

Interpolation 17 (int17)

- 1 In the **Home** toolbar, click **f(x) Functions** and choose **Global>Interpolation**.
- 2 In the **Settings** window for **Interpolation**, locate the **Definition** section.
- 3 From the **Data source** list, choose **Result table**.
- 4 From the **Table from** list, choose **Objective Quality Metrics 1_5**.

5 Find the **Functions** subsection. In the table, enter the following settings:

Function name	Position in file
D50_15	1
C80_15	2
EDT_15	3
T20_15	4

6 Locate the **Interpolation and Extrapolation** section. From the **Interpolation** list, choose **Nearest neighbor**.

7 Locate the **Units** section. In the **Function** table, enter the following settings:

Function	Unit
D50_15	%
C80_15	dB
EDT_15	s
T20_15	s

8 In the **Argument** table, enter the following settings:

Argument	Unit
Column 1	Hz

Interpolation 18 (int18)

1 In the **Home** toolbar, click  **Functions** and choose **Global>Interpolation**.

2 In the **Settings** window for **Interpolation**, locate the **Definition** section.

3 From the **Data source** list, choose **Result table**.

4 From the **Table from** list, choose **Objective Quality Metrics 2_1**.

5 Find the **Functions** subsection. In the table, enter the following settings:

Function name	Position in file
D50_21	1
C80_21	2
EDT_21	3
T20_21	4

6 Locate the **Interpolation and Extrapolation** section. From the **Interpolation** list, choose **Nearest neighbor**.

7 Locate the **Units** section. In the **Function** table, enter the following settings:

Function	Unit
D50_21	%
C80_21	dB
EDT_21	s
T20_21	s

8 In the **Argument** table, enter the following settings:

Argument	Unit
Column 1	Hz

Interpolation 19 (int19)

- 1** In the **Home** toolbar, click  **Functions** and choose **Global>Interpolation**.
- 2** In the **Settings** window for **Interpolation**, locate the **Definition** section.
- 3** From the **Data source** list, choose **Result table**.
- 4** From the **Table from** list, choose **Objective Quality Metrics 2_2**.
- 5** Find the **Functions** subsection. In the table, enter the following settings:

Function name	Position in file
D50_22	1
C80_22	2
EDT_22	3
T20_22	4

6 Locate the **Interpolation and Extrapolation** section. From the **Interpolation** list, choose **Nearest neighbor**.

7 Locate the **Units** section. In the **Function** table, enter the following settings:

Function	Unit
D50_22	%
C80_22	dB
EDT_22	s
T20_22	s

8 In the **Argument** table, enter the following settings:

Argument	Unit
Column 1	Hz

Interpolation 20 (int20)

- 1 In the **Home** toolbar, click **f(∞) Functions** and choose **Global>Interpolation**.
- 2 In the **Settings** window for **Interpolation**, locate the **Definition** section.
- 3 From the **Data source** list, choose **Result table**.
- 4 From the **Table from** list, choose **Objective Quality Metrics 2_3**.
- 5 Find the **Functions** subsection. In the table, enter the following settings:

Function name	Position in file
D50_23	1
C80_23	2
EDT_23	3
T20_23	4

- 6 Locate the **Interpolation and Extrapolation** section. From the **Interpolation** list, choose **Nearest neighbor**.
- 7 Locate the **Units** section. In the **Function** table, enter the following settings:

Function	Unit
D50_23	%
C80_23	dB
EDT_23	s
T20_23	s

8 In the **Argument** table, enter the following settings:

Argument	Unit
Column 1	Hz

Interpolation 21 (int21)

- 1 In the **Home** toolbar, click **f(∞) Functions** and choose **Global>Interpolation**.
- 2 In the **Settings** window for **Interpolation**, locate the **Definition** section.
- 3 From the **Data source** list, choose **Result table**.
- 4 From the **Table from** list, choose **Objective Quality Metrics 2_4**.

5 Find the **Functions** subsection. In the table, enter the following settings:

Function name	Position in file
D50_24	1
C80_24	2
EDT_24	3
T20_24	4

6 Locate the **Interpolation and Extrapolation** section. From the **Interpolation** list, choose **Nearest neighbor**.

7 Locate the **Units** section. In the **Function** table, enter the following settings:

Function	Unit
D50_24	%
C80_24	dB
EDT_24	s
T20_24	s

8 In the **Argument** table, enter the following settings:

Argument	Unit
Column 1	Hz

Interpolation 22 (int22)

1 In the **Home** toolbar, click  **Functions** and choose **Global>Interpolation**.

2 In the **Settings** window for **Interpolation**, locate the **Definition** section.

3 From the **Data source** list, choose **Result table**.

4 From the **Table from** list, choose **Objective Quality Metrics 2_5**.

5 Find the **Functions** subsection. In the table, enter the following settings:

Function name	Position in file
D50_25	1
C80_25	2
EDT_25	3
T20_25	4

6 Locate the **Interpolation and Extrapolation** section. From the **Interpolation** list, choose **Nearest neighbor**.

7 Locate the **Units** section. In the **Function** table, enter the following settings:



Function	Unit
D50_25	%
C80_25	dB
EDT_25	s
T20_25	s

8 In the **Argument** table, enter the following settings:

Argument	Unit
Column I	Hz

Create an empty study to load the newly defined interpolation functions.

ADD STUDY

- 1 In the **Home** toolbar, click  **Add Study** to open the **Add Study** window.
- 2 Go to the **Add Study** window.
- 3 Find the **Studies** subsection. In the **Select Study** tree, select **Empty Study**.
- 4 Click **Add Study** in the window toolbar.
- 5 In the **Home** toolbar, click  **Add Study** to close the **Add Study** window.

STUDY 3 - EMPTY FOR POSTPROCESSING

- 1 In the **Settings** window for **Study**, type Study 3 - Empty for postprocessing in the **Label** text field.
- 2 Locate the **Study Settings** section. Clear the **Generate default plots** check box.

Parametric Sweep

- 1 In the **Study** toolbar, click  **Parametric Sweep**.
- 2 In the **Settings** window for **Parametric Sweep**, locate the **Study Settings** section.
- 3 Click **+ Add**.
- 4 In the table, click to select the cell at row number 1 and column number 2.
- 5 In the table, enter the following settings:

Parameter name	Parameter value list	Parameter unit
f0 (Band center frequency)		Hz

- 6 Click  **Range**.

- 7 In the **Range** dialog box, choose **ISO preferred frequencies** from the **Entry method** list.
- 8 In the **Start frequency** text field, type 100.
- 9 In the **Stop frequency** text field, type 5000.
- 10 From the **Interval** list, choose **1/3 octave**.
- 11 Click **Replace**.
- 12 In the **Study** toolbar, click  **Compute**.

Take the average of the acoustic parameters to obtain their values over the room.

RESULTS

Early Decay Time EDT

- 1 In the **Home** toolbar, click  **Add Plot Group** and choose **ID Plot Group**.
- 2 In the **Settings** window for **ID Plot Group**, type Early Decay Time EDT in the **Label** text field.
- 3 Locate the **Data** section. From the **Dataset** list, choose **Study 3 - Empty for postprocessing/Parametric Solutions 3 (sol42)**.
- 4 From the **Time selection** list, choose **First**.
- 5 Click to expand the **Title** section. From the **Title type** list, choose **Manual**.
- 6 In the **Title** text area, type Average over source-receiver pairs.
- 7 Locate the **Plot Settings** section. Select the **x-axis label** check box.
- 8 In the associated text field, type f (Hz).
- 9 Select the **y-axis label** check box.
- 10 In the associated text field, type EDT (s).
- 11 Locate the **Axis** section. Select the **Manual axis limits** check box.
- 12 In the **x minimum** text field, type 95.
- 13 In the **x maximum** text field, type 5250.
- 14 In the **y minimum** text field, type 0.
- 15 In the **y maximum** text field, type 3.
- 16 Select the **x-axis log scale** check box.

Global I

- 1 Right-click **Early Decay Time EDT** and choose **Global**.
- 2 In the **Settings** window for **Global**, locate the **y-Axis Data** section.

3 In the table, enter the following settings:

Expression	Unit	Description
EDT_meas (f0)	s	Interpolation 9
$(EDT_{11}(f_0)+EDT_{12}(f_0)+EDT_{13}(f_0)+EDT_{14}(f_0)+EDT_{15}(f_0)+EDT_{21}(f_0)+EDT_{22}(f_0)+EDT_{23}(f_0)+EDT_{24}(f_0)+EDT_{25}(f_0))/10$		

4 Locate the **x-Axis Data** section. From the **Axis source data** list, choose **f0**.

5 Click to expand the **Coloring and Style** section. Find the **Line style** subsection. From the **Line** list, choose **Dashed**.

6 Find the **Line markers** subsection. From the **Marker** list, choose **Circle**.

7 From the **Positioning** list, choose **In data points**.

8 Click to expand the **Legends** section. From the **Legends** list, choose **Manual**.

9 In the table, enter the following settings:

Legends
Measurement
Calculation

Global 2

1 In the **Model Builder** window, right-click **Early Decay Time EDT** and choose **Global**.

2 In the **Settings** window for **Global**, locate the **y-Axis Data** section.

3 In the table, enter the following settings:

Expression	Unit	Description
$(1-3*0.05)*EDT_meas(f_0)$	s	

4 Locate the **x-Axis Data** section. From the **Axis source data** list, choose **f0**.

5 Locate the **Coloring and Style** section. Find the **Line style** subsection. From the **Line** list, choose **Dotted**.

6 From the **Color** list, choose **Cycle (reset)**.

7 Locate the **Legends** section. From the **Legends** list, choose **Manual**.

8 In the table, enter the following settings:

Legends
3*JND interval

Global 3

- 1 Right-click **Early Decay Time EDT** and choose **Global**.
- 2 In the **Settings** window for **Global**, locate the **y-Axis Data** section.
- 3 In the table, enter the following settings:

Expression	Unit	Description
$(1+3*0.05)*EDT_meas(f_0)$	s	

- 4 Locate the **x-Axis Data** section. From the **Axis source data** list, choose **f0**.
- 5 Locate the **Coloring and Style** section. Find the **Line style** subsection. From the **Line** list, choose **Dotted**.
- 6 From the **Color** list, choose **Cycle (reset)**.
- 7 Locate the **Legends** section. Clear the **Show legends** check box.
- 8 In the **Early Decay Time EDT** toolbar, click  **Plot**.

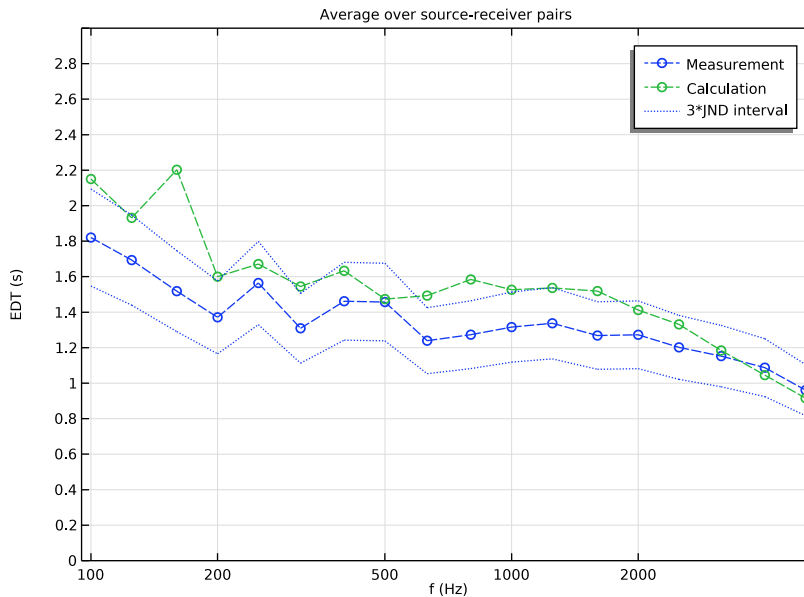

Reverberation Time T20

- 1 In the **Home** toolbar, click  **Add Plot Group** and choose **ID Plot Group**.
- 2 In the **Settings** window for **ID Plot Group**, type Reverberation Time T20 in the **Label** text field.

- 3 Locate the **Data** section. From the **Dataset** list, choose **Study 3 - Empty for postprocessing/Parametric Solutions 3 (sol42)**.
- 4 From the **Time selection** list, choose **First**.
- 5 Click to expand the **Title** section. From the **Title type** list, choose **Manual**.
- 6 In the **Title** text area, type Average over source-receiver pairs.
- 7 Locate the **Plot Settings** section. Select the **x-axis label** check box.
- 8 In the associated text field, type f (Hz).
- 9 Select the **y-axis label** check box.
- 10 In the associated text field, type T20 (s).
- 11 Locate the **Axis** section. Select the **Manual axis limits** check box.
- 12 In the **x minimum** text field, type 95.
- 13 In the **x maximum** text field, type 5250.
- 14 In the **y minimum** text field, type 0.
- 15 In the **y maximum** text field, type 3.
- 16 Select the **x-axis log scale** check box.

Global 1

- 1 Right-click **Reverberation Time T20** and choose **Global**.
- 2 In the **Settings** window for **Global**, locate the **y-Axis Data** section.
- 3 In the table, enter the following settings:

Expression	Unit	Description
T20_meas(f0)	s	Interpolation 10
$(T20_{11}(f0)+T20_{12}(f0)+T20_{13}(f0)+T20_{14}(f0)+T20_{15}(f0)+T20_{21}(f0)+T20_{22}(f0)+T20_{23}(f0)+T20_{24}(f0)+T20_{25}(f0))/10$		

- 4 Locate the **x-Axis Data** section. From the **Axis source data** list, choose **f0**.
- 5 Click to expand the **Coloring and Style** section. Find the **Line style** subsection. From the **Line** list, choose **Dashed**.
- 6 Find the **Line markers** subsection. From the **Marker** list, choose **Circle**.
- 7 From the **Positioning** list, choose **In data points**.
- 8 Click to expand the **Legends** section. From the **Legends** list, choose **Manual**.

9 In the table, enter the following settings:

Legends
Measurement
Calculation

Global 2

- 1 In the **Model Builder** window, right-click **Reverberation Time T20** and choose **Global**.
- 2 In the **Settings** window for **Global**, locate the **y-Axis Data** section.
- 3 In the table, enter the following settings:

Expression	Unit	Description
$(1-3*0.05)*T20_meas(f0)$	s	

- 4 Locate the **x-Axis Data** section. From the **Axis source data** list, choose **f0**.
- 5 Locate the **Coloring and Style** section. Find the **Line style** subsection. From the **Line** list, choose **Dotted**.
- 6 From the **Color** list, choose **Cycle (reset)**.
- 7 Locate the **Legends** section. From the **Legends** list, choose **Manual**.
- 8 In the table, enter the following settings:

Legends
3*JND interval

Global 3

- 1 Right-click **Reverberation Time T20** and choose **Global**.
- 2 In the **Settings** window for **Global**, locate the **y-Axis Data** section.
- 3 In the table, enter the following settings:

Expression	Unit	Description
$(1+3*0.05)*T20_meas(f0)$	s	

- 4 Locate the **x-Axis Data** section. From the **Axis source data** list, choose **f0**.
- 5 Locate the **Coloring and Style** section. Find the **Line style** subsection. From the **Line** list, choose **Dotted**.
- 6 From the **Color** list, choose **Cycle (reset)**.
- 7 Locate the **Legends** section. Clear the **Show legends** check box.

8 In the **Reverberation Time T20** toolbar, click  **Plot**.

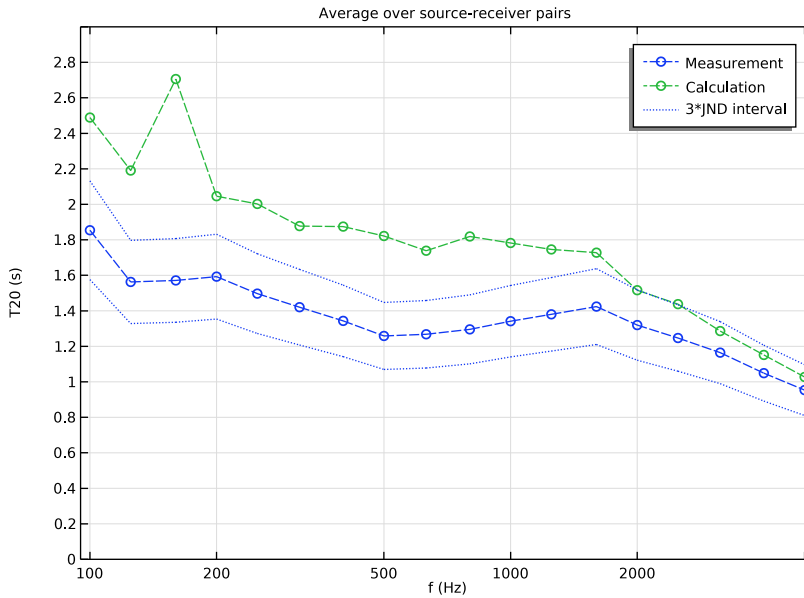

Clarity C80

- 1 In the **Home** toolbar, click  **Add Plot Group** and choose **ID Plot Group**.
- 2 In the **Settings** window for **ID Plot Group**, type Clarity C80 in the **Label** text field.
- 3 Locate the **Data** section. From the **Dataset** list, choose **Study 3 - Empty for postprocessing/Parametric Solutions 3 (sol42)**.
- 4 From the **Time selection** list, choose **First**.
- 5 Click to expand the **Title** section. From the **Title type** list, choose **Manual**.
- 6 In the **Title** text area, type Average over source-receiver pairs.
- 7 Locate the **Plot Settings** section. Select the **x-axis label** check box.
- 8 In the associated text field, type f (Hz).
- 9 Select the **y-axis label** check box.
- 10 In the associated text field, type C80 (dB).
- 11 Locate the **Axis** section. Select the **Manual axis limits** check box.
- 12 In the **x minimum** text field, type 95.
- 13 In the **x maximum** text field, type 5250.
- 14 In the **y minimum** text field, type -5.

- 15 In the **y maximum** text field, type 8.
- 16 Select the **x-axis log scale** check box.
- 17 Locate the **Legend** section. From the **Position** list, choose **Upper left**.

Global 1

- 1 Right-click **Clarity C80** and choose **Global**.
- 2 In the **Settings** window for **Global**, locate the **y-Axis Data** section.
- 3 In the table, enter the following settings:

Expression	Unit	Description
C80_meas (f0)	dB	Interpolation 11
$(C80_11(f0)+C80_12(f0)+C80_13(f0)+C80_14(f0)+C80_15(f0)+C80_21(f0)+C80_22(f0)+C80_23(f0)+C80_24(f0)+C80_25(f0))/10$		

- 4 Locate the **x-Axis Data** section. From the **Axis source data** list, choose **f0**.
- 5 Click to expand the **Coloring and Style** section. Find the **Line style** subsection. From the **Line** list, choose **Dashed**.
- 6 Find the **Line markers** subsection. From the **Marker** list, choose **Circle**.
- 7 From the **Positioning** list, choose **In data points**.
- 8 Click to expand the **Legends** section. From the **Legends** list, choose **Manual**.
- 9 In the table, enter the following settings:

Legends
Measurement
Calculation

Global 2

- 1 In the **Model Builder** window, right-click **Clarity C80** and choose **Global**.
- 2 In the **Settings** window for **Global**, locate the **y-Axis Data** section.
- 3 In the table, enter the following settings:

Expression	Unit	Description
C80_meas (f0) - 3*1	dB	

- 4 Locate the **x-Axis Data** section. From the **Axis source data** list, choose **f0**.

- 5 Locate the **Coloring and Style** section. Find the **Line style** subsection. From the **Line** list, choose **Dotted**.
- 6 From the **Color** list, choose **Cycle (reset)**.
- 7 Locate the **Legends** section. From the **Legends** list, choose **Manual**.
- 8 In the table, enter the following settings:

Legends
3*JND interval

Global 3

- 1 Right-click **Clarity C80** and choose **Global**.
- 2 In the **Settings** window for **Global**, locate the **y-Axis Data** section.
- 3 In the table, enter the following settings:

Expression	Unit	Description
C80_meas (f0)+3*1	dB	

- 4 Locate the **x-Axis Data** section. From the **Axis source data** list, choose **f0**.
- 5 Locate the **Coloring and Style** section. Find the **Line style** subsection. From the **Line** list, choose **Dotted**.
- 6 From the **Color** list, choose **Cycle (reset)**.
- 7 Locate the **Legends** section. Clear the **Show legends** check box.

8 In the **Clarity C80** toolbar, click  **Plot**.

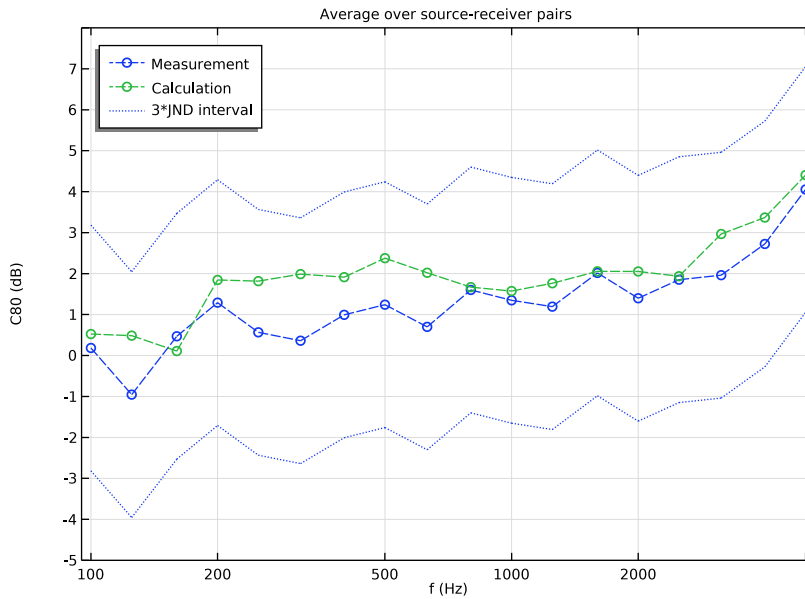

Definition D

- 1 In the **Home** toolbar, click  **Add Plot Group** and choose **ID Plot Group**.
- 2 In the **Settings** window for **ID Plot Group**, type Definition D in the **Label** text field.
- 3 Locate the **Data** section. From the **Dataset** list, choose **Study 3 - Empty for postprocessing/Parametric Solutions 3 (sol42)**.
- 4 From the **Time selection** list, choose **First**.
- 5 Click to expand the **Title** section. From the **Title type** list, choose **Manual**.
- 6 In the **Title** text area, type Average over source-receiver pairs.
- 7 Locate the **Plot Settings** section. Select the **x-axis label** check box.
- 8 In the associated text field, type f (Hz).
- 9 Select the **y-axis label** check box.
- 10 In the associated text field, type D (%).
- 11 Locate the **Axis** section. Select the **Manual axis limits** check box.
- 12 In the **x minimum** text field, type 95.
- 13 In the **x maximum** text field, type 5250.
- 14 In the **y minimum** text field, type 0.

15 In the **y maximum** text field, type 100.

16 Select the **x-axis log scale** check box.

17 Locate the **Legend** section. From the **Position** list, choose **Upper left**.

Global 1

1 Right-click **Definition D** and choose **Global**.

2 In the **Settings** window for **Global**, locate the **y-Axis Data** section.

3 In the table, enter the following settings:

Expression	Unit	Description
D50_meas (f0)	%	Interpolation 12
$100 * (D50_11(f0) + D50_12(f0) + D50_13(f0) + D50_14(f0) + D50_15(f0) + D50_21(f0) + D50_22(f0) + D50_23(f0) + D50_24(f0) + D50_25(f0)) / 10$		

4 Locate the **x-Axis Data** section. From the **Axis source data** list, choose **f0**.

5 Click to expand the **Coloring and Style** section. Find the **Line style** subsection. From the **Line** list, choose **Dashed**.

6 Find the **Line markers** subsection. From the **Marker** list, choose **Circle**.

7 From the **Positioning** list, choose **In data points**.

8 Click to expand the **Legends** section. From the **Legends** list, choose **Manual**.

9 In the table, enter the following settings:

Legends
Measurement
Calculation

Global 2

1 In the **Model Builder** window, right-click **Definition D** and choose **Global**.

2 In the **Settings** window for **Global**, locate the **y-Axis Data** section.

3 In the table, enter the following settings:

Expression	Unit	Description
D50_meas (f0) - 3*0.05	%	

4 Locate the **x-Axis Data** section. From the **Axis source data** list, choose **f0**.

- 5 Locate the **Coloring and Style** section. Find the **Line style** subsection. From the **Line** list, choose **Dotted**.
- 6 From the **Color** list, choose **Cycle (reset)**.
- 7 Locate the **Legends** section. From the **Legends** list, choose **Manual**.
- 8 In the table, enter the following settings:

Legends
3*JND interval

Global 3

- 1 Right-click **Definition D** and choose **Global**.
- 2 In the **Settings** window for **Global**, locate the **y-Axis Data** section.
- 3 In the table, enter the following settings:

Expression	Unit	Description
D50_meas (f0)+3*0.05	%	

- 4 Locate the **x-Axis Data** section. From the **Axis source data** list, choose **f0**.
- 5 Locate the **Coloring and Style** section. Find the **Line style** subsection. From the **Line** list, choose **Dotted**.
- 6 From the **Color** list, choose **Cycle (reset)**.
- 7 Locate the **Legends** section. Clear the **Show legends** check box.

8 In the **Definition D** toolbar, click  **Plot**.

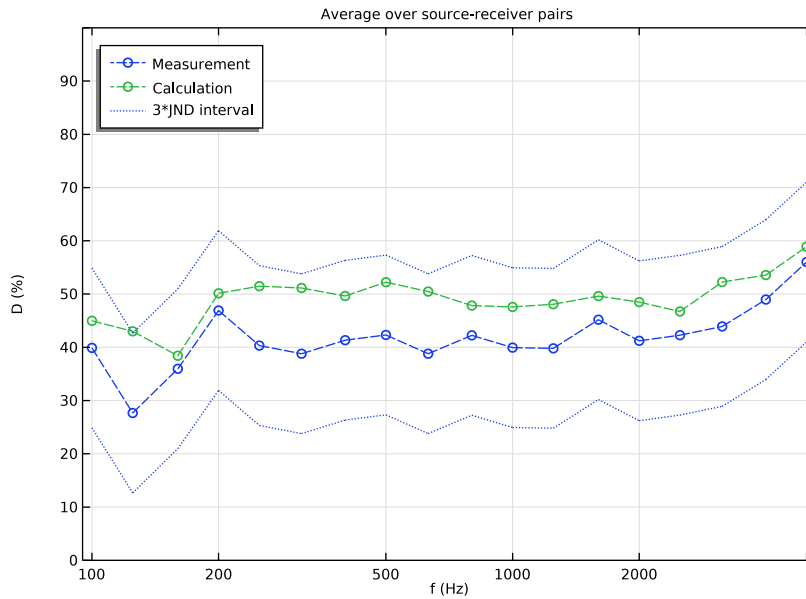

Geometry Modeling Instructions

The geometry in this model was provided by [Ref. 2](#). After importing it, the seating areas are extruded. The surfaces that have become obsolete are then deleted. Finally, surfaces are grouped into selections according to the assignment of materials.

From the **File** menu, choose **New**.

NEW

In the **New** window, click  **Blank Model**.



ADD COMPONENT

In the **Home** toolbar, click  **Add Component** and choose **3D**.

GEOMETRY I

Import 1 (impl)

I In the **Home** toolbar, click  **Import**.



- 2 In the **Settings** window for **Import**, locate the **Import** section.
- 3 Click  **Browse**.
- 4 Browse to the model's Application Libraries folder and double-click the file `chamber_music_hall.mphbin`.
- 5 Click  **Import**.
- 6 Click the  **Wireframe Rendering** button in the **Graphics** toolbar.

Extrude 1 (ext1)

- 1 In the **Geometry** toolbar, click  **Extrude**.
- 2 On the object **imp1**, select Boundary 238 only.
- 3 In the **Settings** window for **Extrude**, locate the **Distances** section.
- 4 In the table, enter the following settings:

Distances (m)
0.8

Extrude 2 (ext2)

- 1 In the **Geometry** toolbar, click  **Extrude**.
- 2 Click the  **Go to Default View** button in the **Graphics** toolbar.
- 3 On the object **ext1**, select Boundaries 197, 213, 408, 419, and 661 only.
- 4 In the **Settings** window for **Extrude**, locate the **Distances** section.
- 5 In the table, enter the following settings:

Distances (m)
0.8

Extrude 3 (ext3)

- 1 In the **Geometry** toolbar, click  **Extrude**.
- 2 On the object **ext2**, select Boundary 724 only.
- 3 In the **Settings** window for **Extrude**, locate the **Distances** section.
- 4 In the table, enter the following settings:

Distances (m)
0.8







Extrude 4 (ext4)

- 1 In the **Geometry** toolbar, click  **Extrude**.

- 2 On the object **ext3**, select Boundary 746 only.
- 3 In the **Settings** window for **Extrude**, locate the **Distances** section.
- 4 In the table, enter the following settings:

Distances (m)
0.8

Delete Entities I (del1)



- 1 In the **Model Builder** window, right-click **Geometry I** and choose **Delete Entities**.
- 2 Click the  **Go to Default View** button in the **Graphics** toolbar.
- 3 On the object **ext4**, select Boundaries 240, 252, 300, 359, 481, 543, and 597 only.
- 4 Click the  **Go to Default View** button in the **Graphics** toolbar.
- 5 On the object **ext4**, select Boundaries 228, 240, 252, 282, 300, 341, 359, 481, 543, and 597 only.
- 6 Click the  **Go to Default View** button in the **Graphics** toolbar.
- 7 On the object **ext4**, select Boundaries 228, 240, 252, 282, 300, 341, 359, 460, 481, 519, 543, 582, and 597 only.
- 8 Click the  **Go to Default View** button in the **Graphics** toolbar.
- 9 On the object **ext4**, select Boundaries 199, 220, 228, 240, 252, 282, 300, 341, 359, 436, 452, 460, 481, 519, 543, 582, and 597 only.
- 10 Click the  **Go to Default View** button in the **Graphics** toolbar.
- 11 On the object **ext4**, select Boundaries 199, 220, 228, 240, 252, 282, 300, 341, 359, 436, 452, 460, 481, 519, 543, 582, 597, 712, 714, 721, 723, 725, 742–744, 746, 750, 754, 755, and 760 only.
- 12 Click the  **Go to Default View** button in the **Graphics** toolbar.
- 13 On the object **ext4**, select Boundaries 199, 220, 228, 240, 252, 282, 300, 341, 359, 436, 452, 460, 481, 519, 543, 582, 597, 712, 714, 721, 723, 725, 742–746, 750, 751, 754, 755, and 760 only.
- 14 Click the  **Go to Default View** button in the **Graphics** toolbar.

Plaster (all)



- 1 In the **Geometry** toolbar, click  **Selections** and choose **Explicit Selection**.
- 2 In the **Settings** window for **Explicit Selection**, type **Plaster (all)** in the **Label** text field.
- 3 Locate the **Entities to Select** section. From the **Geometric entity level** list, choose **Boundary**.

- 4 Click  **Paste Selection**.
- 5 In the **Paste Selection** dialog box, type de11: 1-196, 198, 201-216, 218, 220, 222-245, 250-387, 389-397, 399-410, 413, 415-424, 426, 429-439, 441, 443, 445-476, 478-609, 611-632, 634, 639, 644-680, 682-694, 699-702, 706, 708-713, 716, 718, 724-730 in the **Selection** text field.
- 6 Click **OK**.



Stage panels

- 1 In the **Geometry** toolbar, click  **Selections** and choose **Explicit Selection**.
- 2 In the **Settings** window for **Explicit Selection**, type Stage panels in the **Label** text field.
- 3 Locate the **Entities to Select** section. From the **Geometric entity level** list, choose **Boundary**.
- 4 Click  **Paste Selection**.
- 5 In the **Paste Selection** dialog box, type de11: 10, 11, 13-92 in the **Selection** text field.
- 6 Click **OK**.

Windows

- 1 In the **Geometry** toolbar, click  **Selections** and choose **Explicit Selection**.
- 2 In the **Settings** window for **Explicit Selection**, type Windows in the **Label** text field.
- 3 Locate the **Entities to Select** section. From the **Geometric entity level** list, choose **Boundary**.
- 4 Click  **Paste Selection**.
- 5 In the **Paste Selection** dialog box, type de11: 194, 369, 540, 725-728 in the **Selection** text field.
- 6 Click **OK**.



Seating

- 1 In the **Geometry** toolbar, click  **Selections** and choose **Explicit Selection**.
- 2 In the **Settings** window for **Explicit Selection**, type Seating in the **Label** text field.
- 3 Locate the **Entities to Select** section. From the **Geometric entity level** list, choose **Boundary**.
- 4 Click  **Paste Selection**.
- 5 In the **Paste Selection** dialog box, type de11: 158, 160, 162, 164, 166-169, 195, 197, 199, 200, 205, 209, 211, 222-224, 229, 231, 232, 246-249, 257, 263, 273-275, 280, 282-289, 309, 315, 319, 321, 330-332, 337, 339-346, 370, 376, 379, 381, 388, 411, 412, 414, 425, 427, 428, 445-447, 452,



454, 455, 459-464, 477, 482, 488, 492, 494, 502-504, 509, 511, 512, 516, 517, 521-524, 541, 547, 551, 553, 560, 561, 565, 570, 572, 573, 591, 597, 607, 608, 610, 613, 616, 618-621, 625-628, 635-638, 640-643, 681, 695-698, 703-705, 707, 714, 715, 717, 719-723 in the **Selection** text field.

6 Click **OK**.

Floor



- 1 In the **Geometry** toolbar, click  **Selections** and choose **Explicit Selection**.
 - 2 In the **Settings** window for **Explicit Selection**, type Floor in the **Label** text field.
 - 3 Locate the **Entities to Select** section. From the **Geometric entity level** list, choose **Boundary**.
 - 4 Click  **Paste Selection**.
 - 5 In the **Paste Selection** dialog box, type de11: 12, 96, 98-107, 109-115, 117, 119, 122, 126, 132, 135-140, 142, 146, 150, 154, 155, 184, 185, 188, 190, 193, 298, 300, 304, 363, 365, 368, 390, 393, 396, 397, 408, 413, 473, 475, 476, 534, 536, 539, 612, 617, 622, 624, 631, 632, 639, 659, 677, 684, 685, 699-702, 706, 712, 713, 716, 718, 730 in the **Selection** text field.
- 6 Click **OK**.

Ceiling

- 1 In the **Geometry** toolbar, click  **Selections** and choose **Explicit Selection**.
 - 2 In the **Settings** window for **Explicit Selection**, type Ceiling in the **Label** text field.
 - 3 Locate the **Entities to Select** section. From the **Geometric entity level** list, choose **Boundary**.
 - 4 Click  **Paste Selection**.
 - 5 In the **Paste Selection** dialog box, type de11: 2, 8, 97, 120, 127, 143, 152, 181, 186, 191, 238, 241, 250, 252, 295, 301, 305, 307, 352, 355, 359, 361, 366, 400, 403, 407, 415, 417, 456, 470, 478, 480, 513, 518, 530, 532, 537, 562, 574, 584, 586, 646, 647, 649, 650, 652, 653, 655, 656, 663, 690, 693, 709 in the **Selection** text field.
- 6 Click **OK**.

Structured plaster

- 1 In the **Geometry** toolbar, click  **Selections** and choose **Explicit Selection**.
- 2 In the **Settings** window for **Explicit Selection**, type Structured plaster in the **Label** text field.

- 3 Locate the **Entities to Select** section. From the **Geometric entity level** list, choose **Boundary**.
- 4 Click  **Paste Selection**.
- 5 In the **Paste Selection** dialog box, type del1: 1, 3-7, 9, 108, 121, 128-131, 145, 148, 149, 151, 153, 171-180, 182, 187, 198, 201-204, 206, 208, 212-216, 218, 220, 225, 227, 233, 235, 239, 243, 251, 253, 259-262, 264, 266-272, 276, 278, 290, 292, 296, 303, 306, 308, 311-314, 316, 318, 323, 324, 326-329, 333, 335, 347, 349, 353, 357, 358, 360, 362, 372-375, 377, 378, 382-387, 389, 391, 392, 394, 395, 399, 401, 405, 416, 418, 426, 429-439, 441, 443, 448, 450, 457, 465, 467, 472, 479, 481, 484-487, 489, 491, 496-501, 505, 507, 514, 520, 525, 527, 531, 533, 543-546, 548, 550, 554-559, 563, 566, 568, 576, 577, 579, 585, 587, 593-596, 598, 600-606, 611, 614, 615, 629, 630, 634, 680, 711 in the **Selection** text field.
- 6 Click **OK**.
- 7 In the **Geometry** toolbar, click  **Build All**.
- 8 Click the  **Go to Default View** button in the **Graphics** toolbar.