

# The Brüel & Kjær 4134 Condenser Microphone

## Introduction

---

This is a model of the Brüel and Kjær 4134 condenser microphone (BK 4134). The BK 4134 is a half inch (1/2”) measurement microphone for medium and high level measurements in the audio range and for coupler measurements; see [Figure 1](#). This microphone is of the so-called pressure response type (see [Ref. 1](#) and [Ref. 2](#) for further details). The main output parameter of the model is the microphone sensitivity that relates the electric output of the microphone to the acoustic pressure input. The modeled sensitivity is compared with measurement data from an actual BK 4134 microphone. The mechanical-thermal noise floor of the microphone is also determined by computing the Johnson–Nyquist noise of the system.



*Figure 1: Picture of the Brüel and Kjær 4134 microphone including the protection grid mounted on the housing. Courtesy of Brüel and Kjær.*

The BK 4134 microphone has been the subject of many modeling studies including both numerical, semi-analytical, and analytical models; see, for example, [Ref. 3](#), [Ref. 4](#), and [Ref. 5](#). In the analytical or semi-analytical approaches, not all effects are included as, for example, the nontrivial edge effects of the electric field and thus electric forces acting on the membrane. In this COMSOL Multiphysics finite element model, several physics interfaces and features are used in a multiphysics approach to capture and couple more physical phenomena. These include:

- A *Thermoviscous Acoustics, Frequency Domain* interface, which is the detailed acoustic physics interface that explicitly includes and solves for thermal and viscous loss effects.

- An *Electrostatics* interface captures the changes in the electric field and electrostatic forces.
- A *Membrane* interface, for setting up a pretensioned physics for the diaphragm.
- A *Moving Mesh* feature, for modeling the static deformation of the membrane and computational domain when prepolarizing the microphone.

---

**Note:** Many of the working principles of this microphone model are described in the [Axisymmetric Condenser Microphone](#) model. Application Library path `Acoustics_Module/Electroacoustic_Transducers/condenser_microphone`.

---

### MICROPHONE WORKING PRINCIPLES

A schematic depiction of the microphone is given in [Figure 2](#) including the diaphragm, backplate (or back-electrode), insulator, vent (or pressure equalization hole), housing, and protection grid. The exterior housing and diaphragm are electrically insulated from the backplate with an insulator that seals the volume inside the microphone. A small vent used for pressure equalization at low frequencies is located in the housing.

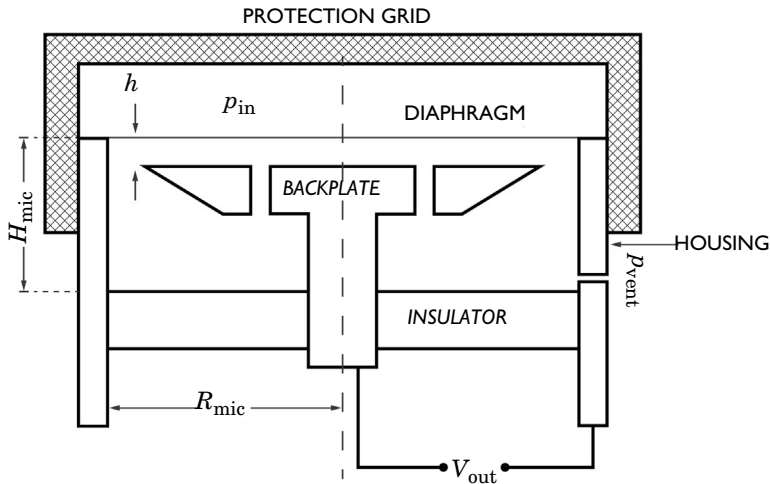

*Figure 2: Schematic representation of the Brüel and Kjer 4134 microphone. Comprising the diaphragm (or membrane) and the backplate (or back electrode), the housing, the insulator, and the protection grid. The incident pressure on the microphone is  $p_{in}$  and the pressure experienced by the vent (pressure equalization hole) is  $p_{vent}$ . The output voltage of the microphone is  $V_{out}$ .*

The distance  $h$  between the diaphragm and the backplate is around 19  $\mu\text{m}$ . The radius of the membrane  $R_{\text{mic}}$  is 4.5 mm and the height  $H_{\text{mic}}$  is 3.35 mm. The microphone works as an electromechanical transducer. It transforms the mechanical movement of the diaphragm, induced by an external incident acoustic pressure field  $p_{\text{in}}$ , into an electric signal  $V_{\text{out}}$ . The relation between the input pressure and the output voltage is the sensitivity level  $L$ , defined as

$$L = 20 \left( \log \left[ \left| \frac{V_{\text{out}}}{p_{\text{in}}} \right| \left( 1 \frac{\text{V}}{\text{Pa}} \right) \right] \right) + L_0 \quad (1)$$

where  $L_0$  is the normalization sensitivity, here the level at 250 Hz. A charge  $Q_0$  is applied to the backplate through a very large resistor in series with a DC polarization voltage  $V_{\text{pol}} = 200 \text{ V}$  (not in the figure). This produces an electrostatic attraction and constant small DC deformation of the diaphragm. Once the diaphragm is set in motion by the incident acoustic field, the gap distance  $h$  varies. This creates an AC voltage between the diaphragm/housing and the backplate.

The shape of the electrode, the location of the holes, and the gap thickness all control the viscothermal damping of the diaphragm motion and thus shapes the microphone response. The low frequency response is influenced by the acoustic impedance of the vent. The vent may either be exposed to the incident pressure field such that  $p_{\text{vent}} = p_{\text{in}} \exp(i\phi)$ , where  $\phi$  is a phase change due to distance, or unexposed (shielded) such that  $p_{\text{vent}} = 0 \text{ Pa}$ . The first configuration is the typical when the microphone is used for field measurements. The second configuration occurs, for example, when the microphone is used for acoustic coupler measurements, where only the membrane is exposed to the sound field. More details are in [Ref. 1](#) and [Ref. 2](#).

#### MODEL ASSUMPTIONS

- In this model it is assumed that the charge  $Q_0$  is constant. This is not fully correct. Electric interaction between the microphone and the external circuit induces small changes in the surface charge. A constant charge corresponds to charging the microphone through an infinitely large resistor. This means that only the acoustic cutoff is modeled at the low frequencies and not the usual combined electric and acoustic cutoff.
- The incident pressure field  $p_{\text{in}}$  is constant across the membrane. This is true for normal incidence. For oblique incidence, the diaphragm diameter  $2R_{\text{mic}}$  becomes comparable to half a wavelength  $\lambda/2$  for  $f = 20 \text{ kHz}$ .

- The microphone casing and protective grid are not modeled. Only the blue colored region in [Figure 2](#) is modeled.
- Using simple symmetries, only the lowest order rotational periodic mode of the diaphragm is computed and modeled.

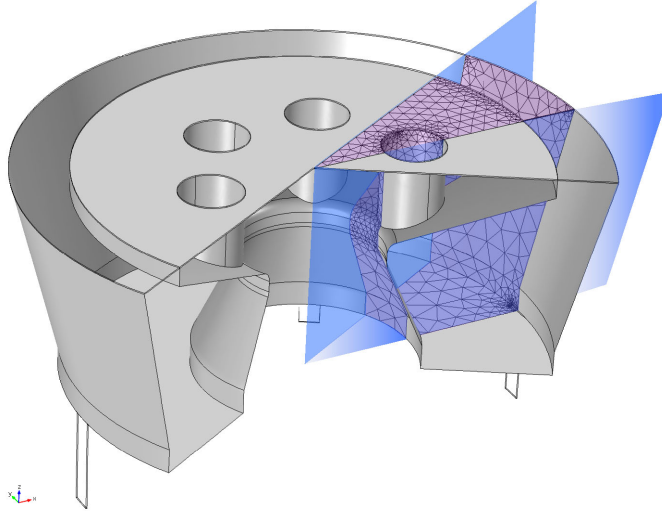

*Figure 3: Geometry of the BK 4134 microphone. The computational mesh is reduced to 1/12 of the geometry using symmetries.*

### **MECHANICAL-THERMAL NOISE PREDICTIONS**

The noise floor also sometimes called thermal noise or mechanical-thermal noise (it is related to the resistive losses of a linear system) is computed for the microphone, see [Ref. 6, 7, and 8](#). The computation is purely based on postprocessing the results of the simulation of the unexposed microphone setup. The Johnson noise or Johnson-Nyquist noise power spectral density is expressed as

$$P_{\text{noise}} = \langle p^2 \rangle = 4k_{\text{B}}T_0R\Delta f \quad (2)$$

where  $k_{\text{B}}$  is Boltzmann's constant,  $T_0$  is the ambient temperature,  $R = \text{real}(Z_{\text{a}})$  is the resistive part of the acoustic impedance, and  $\Delta f$  is the frequency band width (here we will look at the per Hz values and set  $\Delta f = 1$  Hz). This leads to the pressure spectral density of the noise

$$\langle p \rangle = \sqrt{4k_{\text{B}}T_0R} \quad (3)$$

with the SI unit  $\text{Pa}/\sqrt{\text{Hz}}$ . The total weighted level of the mechanical-thermal noise, between the frequencies  $f_1$  and  $f_2$ , can be computed by integrating the spectral density expression (see Ref. 8) as

$$L_W = 20 \log \left( \frac{1}{p_{\text{ref}}} \sqrt{\int_{f_1}^{f_2} 4k_B T_0 R(f) W^2(f) df} \right) \quad (4)$$

where  $W(f)$  is the weighting amplitude function, for example, A-weighted, and  $p_{\text{ref}}$  is the reference pressure of 20  $\mu\text{Pa}$ .

The impedance  $Z_a$  is the acoustic input impedance to the membrane (see Fig. 4 in Ref. 5) and can conveniently be computed as

$$Z_a = \frac{P_{\text{in}}}{Q_{\text{mem}}} \quad Q_{\text{mem}} = i\omega \int_{\text{mem}} wdA \quad (5)$$

where  $Q_{\text{mem}}$  is the average membrane volume velocity. The integral is over the membrane surface (in the model a multiplication with 12 is used to take the sector symmetry into account, the expression is defined in the loaded variables). The resistance can also be computed through the dissipated thermal and viscous heat in the microphone cavity using the (electric) relation

$$R = \frac{P_{\text{th}} + P_{\text{v}}}{\frac{1}{2}|Q_{\text{mem}}|^2} \quad (6)$$

where  $P_{\text{th}}$  and  $P_{\text{v}}$  is the total dissipated thermal and viscous heat. The factor one half is necessary to make the denominator represents and RMS value, just as the heat terms. The heat terms are evaluated in the model as a volume integral of the thermal and viscous power dissipation density variables `ta.diss_therm` and `ta.diss_visc` (the expressions are defined in the loaded variables).

## *Model Definition*

---

### **GEOMETRY**

The geometry of the Brüel and Kjær 4134 microphone is shown in Figure 3. The computational mesh is also shown as a 1/12 slice of the geometry. Using the symmetries of the model, the computational domain is reduced. Because of this symmetric construction the vent has been split into 6 slices (each divided into two with the symmetry)

with the requirement that the total acoustic impedance of the six slices equals the original single hole.

## PARAMETERS

The parameters defined in the model are given in the table below. The properties of air are standard values from the COMSOL air material. The diaphragm is made of nickel and its material parameters are given in the table.

TABLE 1: MODEL PARAMETERS.

VARIABLE	VALUE	DESCRIPTION
$T_{m0}$	3160 N/m	Membrane tension
$E_m$	$2.21 \cdot 10^{11}$ Ps	Young's modulus of membrane
$\nu_m$	0.4	Poisson's ratio for membrane
$t_m$	5 $\mu\text{m}$	Membrane thickness
$\rho_m$	890 $\text{kg}/\text{m}^3$	Membrane density
$\rho_{ms}$	0.0445 $\text{kg}/\text{m}^2$	Membrane surface density ( $= t_m \cdot \rho_m$ )
$Q_0$	$3.145 \cdot 10^{-10}$ C	Electrode charge yielding $V_{\text{pol}} = 200$ V
$p_{\text{in}}$	1 Pa	Incident pressure amplitude
$p_{\text{vent}}$	1 Pa / 0 Pa	Vent pressure (exposed/unexposed)
$f_{\text{max}}$	20 kHz	Maximal study frequency
$d_{\text{visc}}$	$22 \mu\text{m} (100 \text{ Hz}/f_{\text{max}})^{0.5}$	Viscous boundary layer thickness at $f_{\text{max}}$
$L_0$	39.5 dB	Normalization sensitivity

## BOUNDARY CONDITIONS

In the exposed vent configuration, the pressure at the vent is given by

$$p_{\text{vent}} = p_{\text{in}} e^{i\phi} \quad \phi = -kH_{\text{mic}} = -\frac{\omega}{c} H_{\text{mic}} \quad (7)$$

where  $H_{\text{mic}}$  is the height of the microphone (see [Figure 2](#)),  $k$  is the wave number,  $\omega$  is the angular frequency, and  $c = 343$  m/s is the speed of sound at 20°C and 1 atm. It is here assumed that the incident sound is a plane wave normal to the diaphragm.

Details about the other boundary conditions used in this model are found in the [Axisymmetric Condenser Microphone](#) model and in the [Modeling Instructions](#) below.

## Results and Discussion

The sensitivity of the microphone given by Equation 1 is shown in Figure 4. The modeled curves of the exposed and unexposed vent configurations are plotted in blue and pink, respectively. Three measurement curves of actual responses of a BK 4134 microphone are depicted in green, red, and cyan. The measured curves illustrate the variability in the sensitivity of a microphone — this is why each measurement microphone is delivered with an individual calibration curve. The measured curves are only valid from 200 Hz and upward. The microphone sensitivity is also illustrated in 1/3 octaves at the very end of this model description.

The frequency response of the microphone for frequencies below 100 Hz shows different behavior depending on the vent configuration (compare this to Fig. 2.7 in Ref. 2). In the exposed configuration the vent equalizes the pressure on both sides of the membrane (the phase lag  $\phi$  is small) and thus reduces the pressure drop across the diaphragm, in turn reducing the sensitivity. In the unexposed configuration, the sensitivity is seen to increase at the lowest frequencies. Here the stiffness of the internal air cavity becomes smaller.

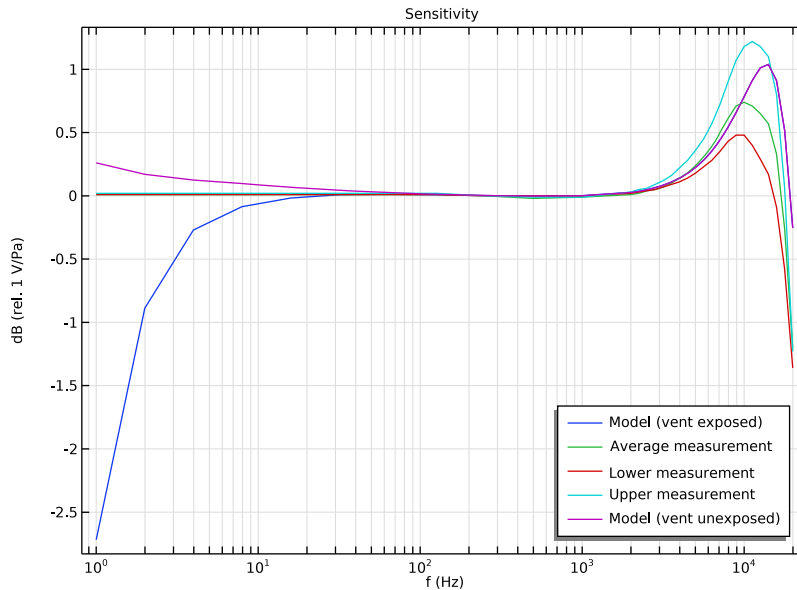

*Figure 4: Microphone sensitivity curve from the model with vent exposed (blue) and vent unexposed (pink). Three measurement curves are also added (green, red, and cyan) to illustrate the variability in the microphone sensitivity.*



The deformation of the membrane is shown in [Figure 5](#) for 20 kHz and 1 kHz, top and bottom, respectively. At 20 kHz, where the sensitivity starts to fall off, the influence of the holes on the membrane deformation is visible (see for example, [Ref. 4](#) for measured membrane modes).

The static electric potential distribution that results from prepolarizing the microphone is shown in [Figure 6](#); notice that the maximal voltage is just over 200 V.

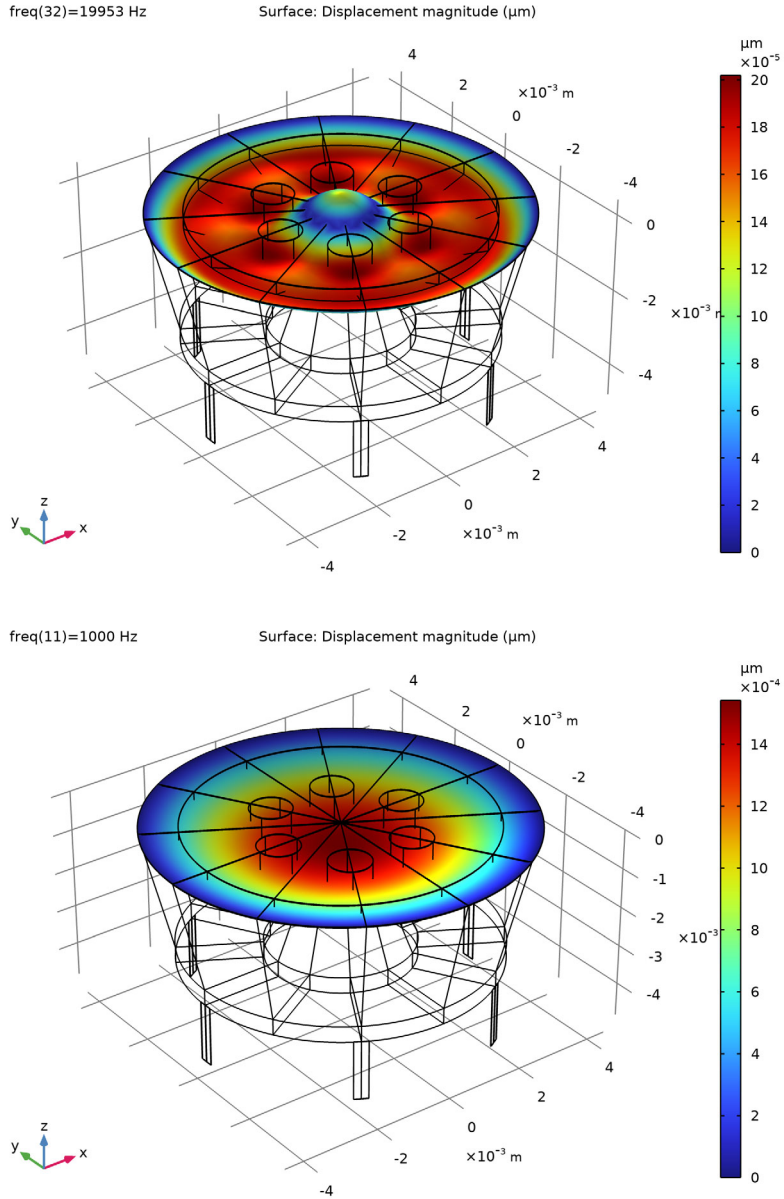
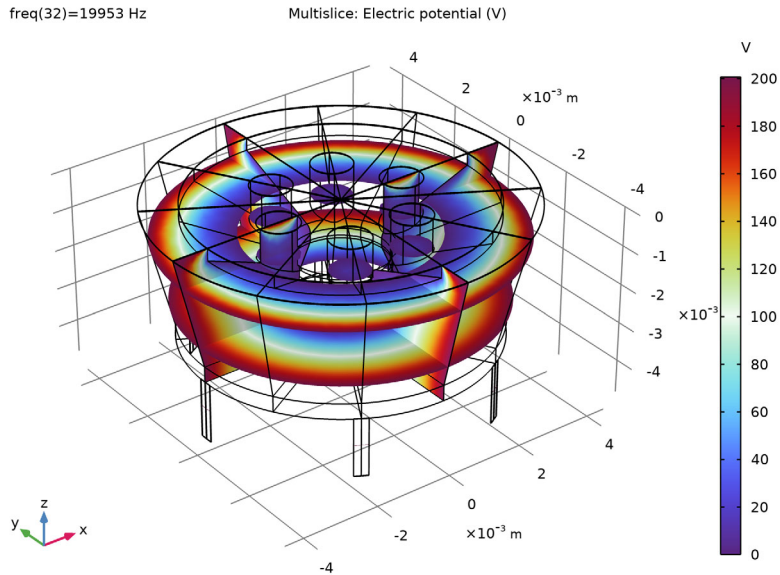

Figure 5: Diaphragm deformation at  $f = 20 \text{ kHz}$  (top) and  $f = 1 \text{ kHz}$  (bottom).



*Figure 6: Static electric potential resulting from the prepolarization of the microphone cartridge and diaphragm.*

#### **MECHANICAL-THERMAL NOISE RESULTS**

The computation of the noise is based on the expressions in [Equation 2](#) to [Equation 6](#) and is purely postprocessing of the computed solution. The results are, for simplicity, based on the unexposed vent setup. When the vent is exposed, the equivalent circuit of the acoustic system becomes a bit more complicated as two sources are present. Some measurement data of the noise in the BK 4134 microphone can be found in [Ref. 8](#) and [Ref. 9](#).

The dissipated total, thermal, and viscous heat inside the microphone cavity are depicted in [Figure 7](#) (left). The computed equivalent acoustic resistance  $R$  used for the noise computation is depicted in [Figure 7](#) (right). The resistance is computed through both [Equation 5](#) and [Equation 6](#). The values of the resistance are consistent with the results from [Ref. 8](#) (see [Fig. 3](#) in the reference).

In the same reference, the A-weighted total noise level is also reported (see [Table II](#) in the reference). Using the computed data for the resistance  $R(f)$  and [Equation 4](#) the A-weighted noise level can readily be computed as  $L_W = 18.7$  dB(A). This value is very close to the other reported values. It should be noted that no assumptions have been made in

the simulation results, whereas several of the reported values are based on analytical models that do not capture all details of the physics, for example, the low frequency transition to isothermal behavior.

Finally, the mechanical-thermal noise spectral density curves are depicted in [Figure 8](#) as a power spectral density (top left), a pressure spectral density (top right), and the equivalent noise floor sound pressure level (bottom).

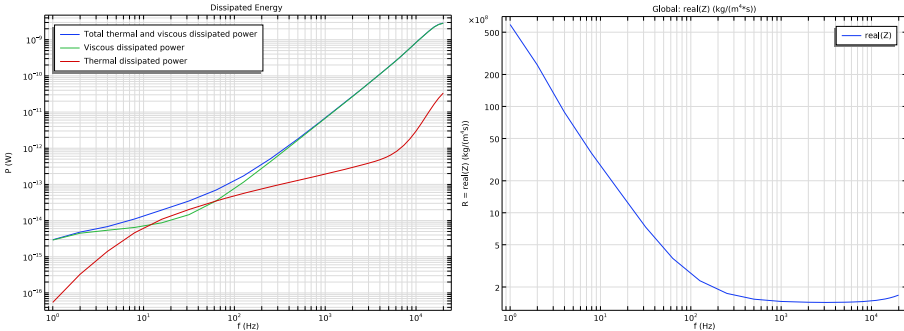

*Figure 7: (left) Total, thermal, and viscous dissipated power, and (right) equivalent acoustic resistance computed directly and through the dissipated power.*

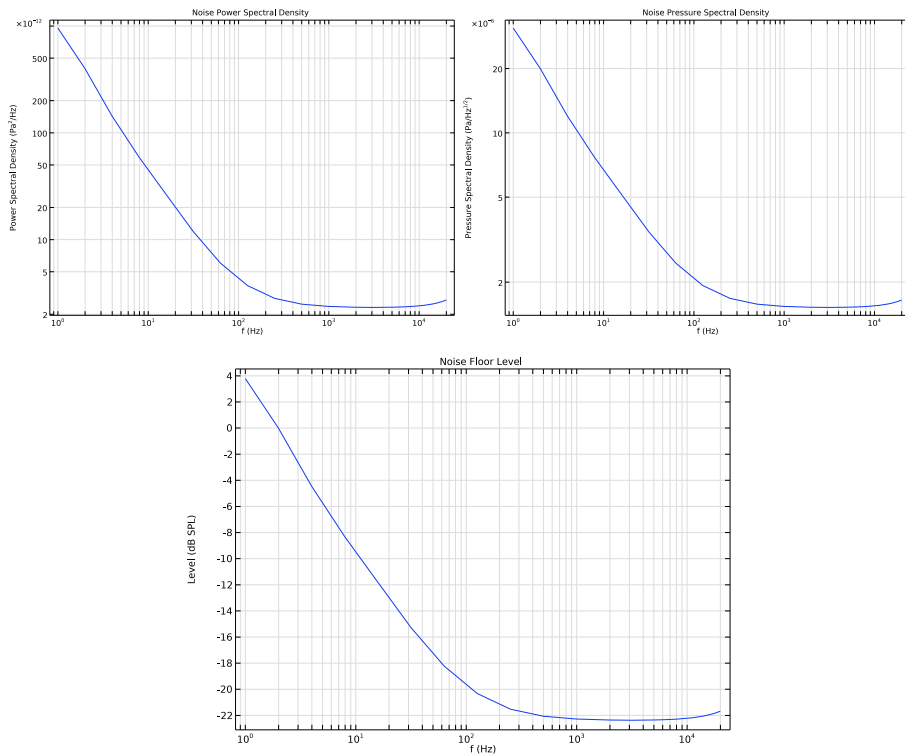

Figure 8: The computed noise spectral density depicted as the power (top left), pressure (top right), and the level (bottom).

## References

1. Brüel & Kjær, “Condenser Microphones and Microphone Preamplifiers for Acoustic Measurements,” *Data Handbook be0089*, 1982.
2. Brüel & Kjær, *Microphone Handbook, vol. 1: Theory*, Technical Documentation be1447, 1996.
3. D. Homencovski and R. N. Miles, “An analytical-numerical method for determining the mechanical response of a condenser microphone,” *J. Acoust. Soc. Am.*, vol. 130, pp. 3698, 2011.

4. T. Lavergne, S. Durand, M. Bruneau, N. Joly, and D. Rodrigues, “Dynamic behavior of the circular membrane of an electrostatic microphone: Effect of holes in the backing electrode,” *J. Acoust. Soc. Am.*, vol. 128, pp. 3459, 2010.
5. A.J. Zuckerwar, “Theoretical response of condenser microphones,” *J. Acoust. Soc. Am.*, vol. 64, p. 1278, 1978.
6. B. Russo, “Thermal Noise in Condenser Microphone Back volumes,” Master Thesis, Pen. State University, 2013.
7. J. Esteves, L. Rufer, D. Ekeom, and S. Basrour, “Lumped-parameters equivalent circuit for condenser microphones modeling,” *J. Acoust. Soc. Am.*, vol. 142, p. 2121, 2017.
8. C. W. Tan and J. Miao, “Modified Škvor/Starr approach in the mechanical-thermal noise analysis of condenser microphone,” *J. Acoust. Soc. Am.*, vol. 126, p. 2301, 2009.
9. A. J. Zuckerwar and K. C. T. Ngo, “Measured  $1/f$  noise in the membrane motion of condenser microphones,” *J. Acoust. Soc. Am.*, vol. 95, p. 1419, 1994.

---

**Application Library path:** Acoustics\_Module/Electroacoustic\_Transducers/  
bk\_4134\_microphone

---

### *Modeling Instructions*

---

From the **File** menu, choose **New**.

#### **NEW**

In the **New** window, click  **Model Wizard**.

#### **MODEL WIZARD**

- 1 In the **Model Wizard** window, click  **3D**.
- 2 In the **Select Physics** tree, select **Acoustics>Thermoviscous Acoustics>Thermoviscous Acoustics, Frequency Domain (ta)**.
- 3 Click **Add**.
- 4 In the **Select Physics** tree, select **Structural Mechanics>Membrane (mbrn)**.
- 5 Click **Add**.
- 6 In the **Displacement field** text field, type um.

7 In the **Displacement field components** table, enter the following settings:

um

vm

wm

The displacement field of the membrane is (um,vm,w<sub>m</sub>) while the velocity field in the fluid is (u,v,w).

8 In the **Select Physics** tree, select **AC/DC>Electric Fields and Currents>Electrostatics (es)**.

9 Click **Add**.

10 Click  **Done**.

## GEOMETRY I

Skip setting up the study types for now because a couple of manual steps are needed to set up the linear perturbation solver properly.

Import the parameters that define the diaphragm material, static surface charge, and incident and vent pressures as well as some mesh related parameters. The parameters are presented in [Table 1](#).

## GLOBAL DEFINITIONS

### *Parameters I*

1 In the **Model Builder** window, under **Global Definitions** click **Parameters I**.

2 In the **Settings** window for **Parameters**, locate the **Parameters** section.

3 Click  **Load from File**.

4 Browse to the model's Application Libraries folder and double-click the file `bk_4134_microphone_parameters.txt`.

Import the geometry which represents one 12th of the Brüel and Kjør 4134 microphone, see [Figure 3](#). The geometry is courtesy of Brüel and Kjør.

## GEOMETRY I

### *Import I (impI)*

1 In the **Home** toolbar, click  **Import**.

2 In the **Settings** window for **Import**, locate the **Import** section.

3 Click  **Browse**.

4 Browse to the model's Application Libraries folder and double-click the file `bk_4134_microphone.mphbin`.

5 Click  **Import**.

Next, add a workplane to partition the geometry to simplify meshing.

#### *Work Plane 1 (wp1)*

1 In the **Geometry** toolbar, click  **Work Plane**.

2 In the **Settings** window for **Work Plane**, locate the **Plane Definition** section.

3 From the **Offset type** list, choose **Through vertex**.

4 Find the **Offset vertex** subsection. Click to select the  **Activate Selection** toggle button.

5 On the object **imp1**, select Point 40 only.

6 Click  **Build Selected**.

#### *Partition Objects 1 (par1)*

1 In the **Geometry** toolbar, click  **Booleans and Partitions** and choose **Partition Objects**.

2 Select the object **imp1** only.

3 In the **Settings** window for **Partition Objects**, locate the **Partition Objects** section.

4 From the **Partition with** list, choose **Work plane**.

5 Click  **Build Selected**.

#### *Work Plane 1 (wp1)*

In the **Model Builder** window, collapse the **Component 1 (comp1)>Geometry 1>Work Plane 1 (wp1)** node.



### Form Union (fin)

1 In the **Geometry** toolbar, click  **Build All**.

The geometry should look like the one in the figure below.

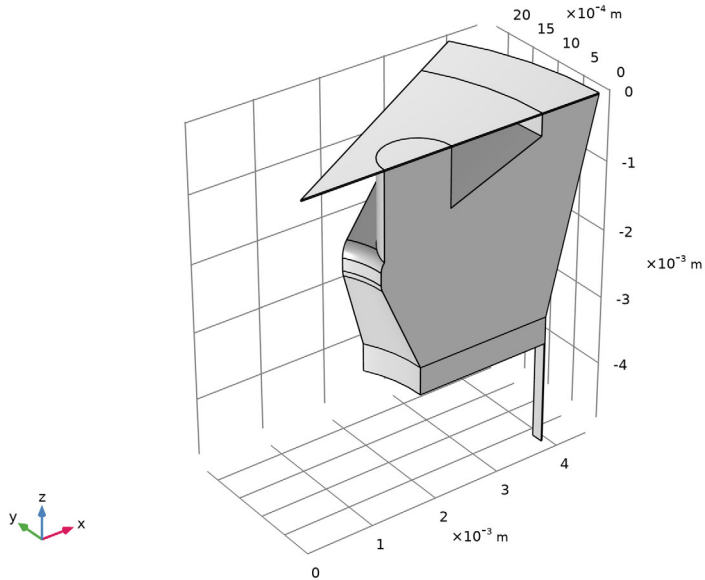

Next, add three interpolation functions that represent measurement data of the sensitivity of an actual microphone.

### DEFINITIONS

#### Interpolation 1 (int1)

1 In the **Home** toolbar, click  **Functions** and choose **Local>Interpolation**.

2 In the **Settings** window for **Interpolation**, locate the **Definition** section.

3 From the **Data source** list, choose **File**.

4 Click  **Browse**.

5 Browse to the model's Application Libraries folder and double-click the file `bk_4134_microphone_sensitivity_data.txt`.

6 In the **Number of arguments** text field, type 1.

7 Click  **Import**.

**8** Find the **Functions** subsection. In the table, enter the following settings:



Function name	Position in file
int_ave	1
int_min	2
int_max	3

Add predefined selections of boundaries to use when setting up the rest of the physics in the model. Rename the selections such that they are easy to use.

#### *Membrane*

- 1** In the **Definitions** toolbar, click  **Explicit**.
- 2** In the **Settings** window for **Explicit**, locate the **Input Entities** section.
- 3** From the **Geometric entity level** list, choose **Boundary**.
- 4** Select Boundaries 4, 16, and 29 only.
- 5** In the **Label** text field, type Membrane.

#### *Symmetry*

- 1** In the **Definitions** toolbar, click  **Explicit**.
- 2** In the **Settings** window for **Explicit**, type Symmetry in the **Label** text field.
- 3** Locate the **Input Entities** section. From the **Geometric entity level** list, choose **Boundary**.
- 4** Click the  **Wireframe Rendering** button in the **Graphics** toolbar.  
Use the wireframe rendering for easier visualization of the selections.
- 5** Select Boundaries 1, 2, 5, 11, 14, 18, 23, 24, 27, 32, 34, and 37 only.

- 6 Click the  **Zoom Extents** button in the **Graphics** toolbar.

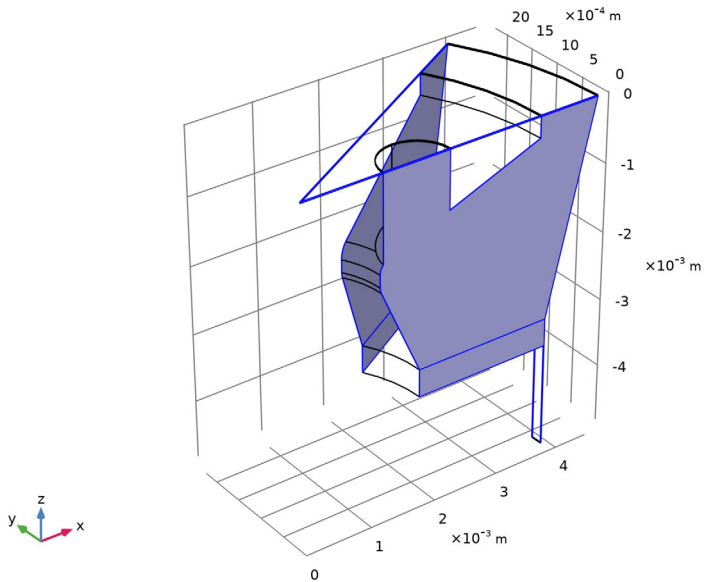

#### *Pressure Release*

- 1 In the **Definitions** toolbar, click  **Explicit**.
- 2 In the **Settings** window for **Explicit**, type Pressure Release in the **Label** text field.
- 3 Locate the **Input Entities** section. From the **Geometric entity level** list, choose **Boundary**.
- 4 Select Boundary 35 only.

#### *Ground*

- 1 In the **Definitions** toolbar, click  **Explicit**.
- 2 In the **Settings** window for **Explicit**, type Ground in the **Label** text field.
- 3 Locate the **Input Entities** section. From the **Geometric entity level** list, choose **Boundary**.
- 4 Select Boundaries 3, 6–10, 12, 17, 21, and 25 only.

#### *Terminal*

- 1 In the **Definitions** toolbar, click  **Explicit**.
- 2 In the **Settings** window for **Explicit**, type Terminal in the **Label** text field.
- 3 Locate the **Input Entities** section. From the **Geometric entity level** list, choose **Boundary**.

- 4 Select Boundaries 4, 16, 29–31, 36, and 39 only.

Select air as the material to be used in the model and set up a material with the membrane properties.

#### ADD MATERIAL

- 1 In the **Home** toolbar, click  **Add Material** to open the **Add Material** window.
- 2 Go to the **Add Material** window.
- 3 In the tree, select **Built-in>Air**.
- 4 Click **Add to Component** in the window toolbar.

#### MATERIALS

##### *Membrane Material*

- 1 In the **Model Builder** window, under **Component 1 (comp1)** right-click **Materials** and choose **Blank Material**.
- 2 In the **Settings** window for **Material**, type **Membrane Material** in the **Label** text field.
- 3 Locate the **Geometric Entity Selection** section. From the **Geometric entity level** list, choose **Boundary**.
- 4 From the **Selection** list, choose **Membrane**.
- 5 Locate the **Material Contents** section. In the table, enter the following settings:

Property	Variable	Value	Unit	Property group
Young's modulus	E	Em	Pa	Young's modulus and Poisson's ratio
Poisson's ratio	nu	num		Young's modulus and Poisson's ratio
Density	rho	rhom	kg/m <sup>3</sup>	Basic

- 6 In the **Home** toolbar, click  **Add Material** to close the **Add Material** window.  
To set up the acoustic model, set the acoustic velocity equal to the deformation of the diaphragm, provide two pressure boundary conditions at the vent (exposed and unexposed), and apply symmetry conditions. When solving the model, only one of the pressure boundary conditions at a time will be active.

## THERMOVISCOUS ACOUSTICS, FREQUENCY DOMAIN (TA)

### *Symmetry 1*

- 1 In the **Model Builder** window, under **Component 1 (comp1)** right-click **Thermoviscous Acoustics, Frequency Domain (ta)** and choose **Symmetry**.
- 2 In the **Settings** window for **Symmetry**, locate the **Boundary Selection** section.
- 3 From the **Selection** list, choose **Symmetry**.

### *Pressure (Adiabatic) 1*

- 1 In the **Physics** toolbar, click  **Boundaries** and choose **Pressure (Adiabatic)**.
- 2 In the **Settings** window for **Pressure (Adiabatic)**, locate the **Boundary Selection** section.
- 3 From the **Selection** list, choose **Pressure Release**.
- 4 Locate the **Pressure** section. In the  $p_{\text{bnd}}$  text field, type `linper(pvent_e*exp(-ta.iomega*Hmic/343[m/s]))`.

See the expression for the vent pressure given in [Equation 7](#).

### *Pressure (Adiabatic) 2*

- 1 In the **Physics** toolbar, click  **Boundaries** and choose **Pressure (Adiabatic)**.
- 2 In the **Settings** window for **Pressure (Adiabatic)**, locate the **Boundary Selection** section.
- 3 From the **Selection** list, choose **Pressure Release**.
- 4 Locate the **Pressure** section. In the  $p_{\text{bnd}}$  text field, type `linper(pvent_u)`.

The `linper()` operator is used to indicate load terms that should only be included when solving the linear perturbation part of the model, that is, the frequency-dependent terms. For more information look under **Help > Documentation** and search for Special Operators.

Model the diaphragm using the Membrane interface. Constrain the membrane at the outer ridge, add an initial stress equal to the membrane tension  $T_{m0}$ , and set up zero displacement in the horizontal plane on the symmetry edges. Finally, add the forces/loads that act on the membrane, that is, the incident pressure field  $P_{in}$  and the electrostatic forces given by the Maxwell stress tensor components (`es.dnTex`, `es.dnTey`, `es.dnTez`).

## MEMBRANE (MBRN)

- 1 In the **Model Builder** window, under **Component 1 (comp1)** click **Membrane (mbrn)**.
- 2 In the **Settings** window for **Membrane**, locate the **Boundary Selection** section.
- 3 From the **Selection** list, choose **Membrane**.

### *Thickness and Offset 1*

- 1 In the **Model Builder** window, under **Component 1 (comp1)>Membrane (mbrn)** click **Thickness and Offset 1**.
- 2 In the **Settings** window for **Thickness and Offset**, locate the **Thickness and Offset** section.
- 3 In the  $d$  text field, type **tm**.

### *Linear Elastic Material 1*

In the **Model Builder** window, click **Linear Elastic Material 1**.

### *Initial Stress and Strain 1*

- 1 In the **Physics** toolbar, click  **Attributes** and choose **Initial Stress and Strain**.
- 2 In the **Settings** window for **Initial Stress and Strain**, locate the **Initial Stress and Strain** section.
- 3 In the  $N_0$  table, enter the following settings:

Tm0	0
0	Tm0

### *Fixed Constraint 1*

- 1 In the **Physics** toolbar, click  **Edges** and choose **Fixed Constraint**.
- 2 Select Edge 76 only.

### *Symmetry 1*

- 1 In the **Physics** toolbar, click  **Edges** and choose **Symmetry**.
- 2 Select Edges 4, 5, 25, 44, 51, and 59 only.

### *Face Load 1*

- 1 In the **Physics** toolbar, click  **Boundaries** and choose **Face Load**.
- 2 In the **Settings** window for **Face Load**, locate the **Boundary Selection** section.
- 3 From the **Selection** list, choose **Membrane**.
- 4 Locate the **Force** section. From the **Load type** list, choose **Pressure**.
- 5 In the  $p$  text field, type **1inper(pin)**.

### *Face Load 2*

- 1 In the **Physics** toolbar, click  **Boundaries** and choose **Face Load**.
- 2 In the **Settings** window for **Face Load**, locate the **Boundary Selection** section.

3 From the **Selection** list, choose **Membrane**.

Proceed to set up the Electrostatics interface. Add a ground boundary, a terminal boundary with a constant charge  $Q_0$ , and the **Force Calculation** that will announce the electrostatic forces. Once added, the forces can be selected in the **Face Load** feature.

## ELECTROSTATICS (ES)

In the **Model Builder** window, under **Component 1 (comp1)** click **Electrostatics (es)**.

### Ground 1

- 1 In the **Physics** toolbar, click  **Boundaries** and choose **Ground**.
- 2 In the **Settings** window for **Ground**, locate the **Boundary Selection** section.
- 3 From the **Selection** list, choose **Ground**.

### Terminal 1

- 1 In the **Physics** toolbar, click  **Boundaries** and choose **Terminal**.
- 2 In the **Settings** window for **Terminal**, locate the **Boundary Selection** section.
- 3 From the **Selection** list, choose **Terminal**.
- 4 Locate the **Terminal** section. In the  $Q_0$  text field, type 00.

Finally, add the **Force Calculation** feature that will announce the electrostatic forces used in the Membrane physics.

### Force Calculation 1

- 1 In the **Physics** toolbar, click  **Domains** and choose **Force Calculation**.
- 2 Select Domains 1, 3, and 5 only.

Go back to the **Face Load** feature and select the Maxwell surface stress tensor as the applied force.

## MEMBRANE (MBRN)

### Face Load 2

- 1 In the **Model Builder** window, under **Component 1 (comp1)**>**Membrane (mbrn)** click **Face Load 2**.
- 2 In the **Settings** window for **Face Load**, locate the **Force** section.
- 3 From the  $\mathbf{F}_A$  list, choose **Maxwell surface stress tensor (es/fcall)**.

Set up the **Moving Mesh** feature. This feature allows for a precise calculation of the stationary shape of the membrane, the electric field, and forces. Set a **Symmetry**

condition on the symmetry boundaries. The deformation of the (adjacent) membrane is automatically used as the mesh movement on the boundary.

## COMPONENT 1 (COMP1)

### *Deforming Domain 1*

1 In the **Definitions** toolbar, click  **Moving Mesh** and choose **Domains>Deforming Domain**.

2 Select Domains 1, 3, and 5 only.

### *Fixed Boundary 1*

1 In the **Definitions** toolbar, click  **Moving Mesh** and choose **Boundaries>Fixed Boundary**.

2 Select Boundaries 3, 15, and 28 only.

### *Symmetry/Roller 1*

1 In the **Definitions** toolbar, click  **Moving Mesh** and choose **Boundaries>Symmetry/Roller**.

2 In the **Settings** window for **Symmetry/Roller**, locate the **Boundary Selection** section.

3 From the **Selection** list, choose **Symmetry**.

Finally, proceed with coupling the membrane to the acoustics using the predefined multiphysics coupling.

## MULTIPHYSICS

### *Thermoviscous Acoustic-Structure Boundary 1 (tsb1)*

1 In the **Physics** toolbar, click  **Multiphysics Couplings** and choose **Boundary>Thermoviscous Acoustic-Structure Boundary**.

2 In the **Settings** window for **Thermoviscous Acoustic-Structure Boundary**, locate the **Boundary Selection** section.

3 From the **Selection** list, choose **Membrane**.

You have now defined all the physics, multiphysics, and boundary conditions of the model. Proceed with defining the computational mesh. Because the model is large and the mesh has to be used for a wide frequency range, some compromise is needed. The mesh has to resolve the acoustic boundary layer for all frequencies, here we will create a mesh that is good in most cases. While setting up the mesh, it can be a good idea to switch to **Wireframe Rendering** rendering. As the mesh is set up manually, proceed by directly adding the first mesh component.



## MESH 1

### *Mapped 1*

- 1 In the **Mesh** toolbar, click  **Boundary** and choose **Mapped**.
- 2 Select Boundary 36 only.

### *Distribution 1*

- 1 Right-click **Mapped 1** and choose **Distribution**.
- 2 Select Edge 70 only.

## MESH 1



### *Free Triangular 1*

- 1 In the **Model Builder** window, expand the **Results** node.
- 2 Right-click **Component 1 (comp1)>Mesh 1** and choose **Boundary Generators>Free Triangular**.
- 3 Select Boundaries 4, 16, 19, and 29 only.

### *Size 1*

- 1 Right-click **Free Triangular 1** and choose **Size**.
- 2 In the **Settings** window for **Size**, locate the **Element Size** section.
- 3 Click the **Custom** button.
- 4 Locate the **Element Size Parameters** section.
- 5 Select the **Maximum element size** check box. In the associated text field, type 0.4[mm].

### *Size 2*

- 1 In the **Model Builder** window, right-click **Free Triangular 1** and choose **Size**.
- 2 In the **Settings** window for **Size**, locate the **Geometric Entity Selection** section.
- 3 From the **Geometric entity level** list, choose **Edge**.
- 4 Select Edges 24, 36, and 50 only.
- 5 Locate the **Element Size** section. Click the **Custom** button.
- 6 Locate the **Element Size Parameters** section.
- 7 Select the **Maximum element size** check box. In the associated text field, type 4\*dv1isc.
- 8 Click  **Build Selected**.
- 9 Click the  **Zoom Extents** button in the **Graphics** toolbar.

### *Swept 1*

- 1 In the **Mesh** toolbar, click  **Swept**.
- 2 In the **Settings** window for **Swept**, locate the **Domain Selection** section.
- 3 From the **Geometric entity level** list, choose **Domain**.
- 4 Select Domains 1 and 3–6 only.



### *Distribution 1*

- 1 Right-click **Swept 1** and choose **Distribution**.
- 2 In the **Settings** window for **Distribution**, locate the **Domain Selection** section.
- 3 Click  **Clear Selection**.
- 4 Select Domains 1, 3, and 5 only.
- 5 Locate the **Distribution** section. In the **Number of elements** text field, type 3.

### *Distribution 2*

- 1 In the **Model Builder** window, right-click **Swept 1** and choose **Distribution**.
- 2 In the **Settings** window for **Distribution**, locate the **Domain Selection** section.
- 3 Click  **Clear Selection**.
- 4 Select Domain 4 only.
- 5 Locate the **Distribution** section. In the **Number of elements** text field, type 2.

### *Distribution 3*

- 1 Right-click **Swept 1** and choose **Distribution**.
- 2 In the **Settings** window for **Distribution**, locate the **Domain Selection** section.
- 3 Click  **Clear Selection**.
- 4 Select Domain 6 only.
- 5 Click  **Build Selected**.

### *Free Tetrahedral 1*

In the **Mesh** toolbar, click  **Free Tetrahedral**.

### *Size 1*

- 1 Right-click **Free Tetrahedral 1** and choose **Size**.
- 2 In the **Settings** window for **Size**, locate the **Element Size** section.
- 3 Click the **Custom** button.
- 4 Locate the **Element Size Parameters** section.
- 5 Select the **Maximum element size** check box. In the associated text field, type 0.5[mm].

6 Click  **Build Selected**.

#### *Boundary Layers I*

- 1 In the **Mesh** toolbar, click  **Boundary Layers**.
- 2 In the **Settings** window for **Boundary Layers**, click to expand the **Transition** section.
- 3 Clear the **Smooth transition to interior mesh** check box.

#### *Boundary Layer Properties*

- 1 In the **Model Builder** window, click **Boundary Layer Properties**.
- 2 Select Boundaries 6–10, 12, 13, 17, 19, 21, 22, 25, 26, 30, 31, 36, and 39 only.
- 3 In the **Settings** window for **Boundary Layer Properties**, locate the **Layers** section.
- 4 In the **Number of layers** text field, type 3.
- 5 From the **Thickness specification** list, choose **All layers**.
- 6 In the **Total thickness** text field, type  $\pi * d_{visc}$ .

7 Click  **Build All.**

The final mesh should look like that in the figure below.

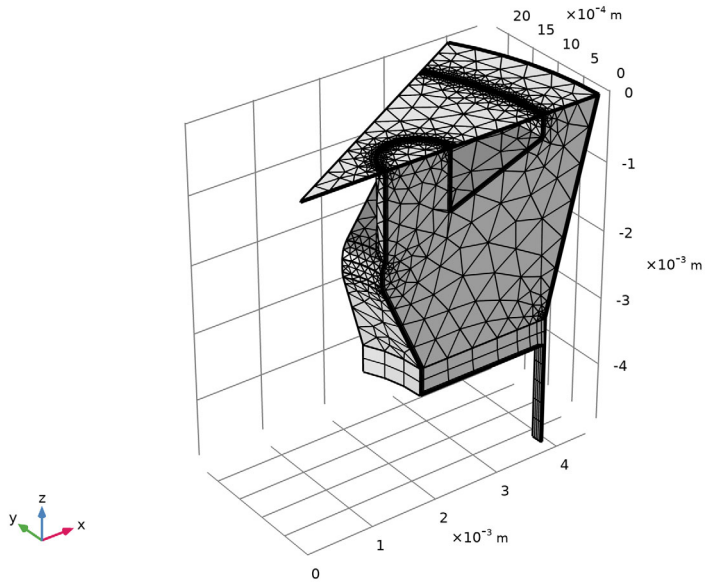

Add two studies to solve the model: one for the case where the vent is exposed to the incident pressure  $P_{in}$  and another for the case where the vent is unexposed (shielded) from the incident pressure field.

Solve the model using the linear-perturbation solver in the frequency domain. In order for the solver to work, first perform a stationary study to determine the linearization point. This first study deforms the membrane and mesh due to the electrostatic forces (from the DC polarization voltage) and includes the effects of the static membrane tension  $T_{m0}$ . The second study models the acoustic perturbation to the static solution, that is the small-parameter harmonic variations of the acoustic pressure, temperature, and velocity.

Because this is a strongly coupled multiphysics problem, set the stationary solver to fully coupled (in contrast to the default segregated type). The frequency domain solver is fully coupled, per default, when frequency domain perturbation is used. Also set the solvers to be direct and in the frequency domain step use PARDISO. The model should solve on a computer with 6 GB of RAM or more.

## ADD STUDY

- 1 In the **Home** toolbar, click  **Add Study** to open the **Add Study** window.
- 2 Go to the **Add Study** window.
- 3 Find the **Physics interfaces in study** subsection. In the table, clear the **Solve** check box for **Thermoviscous Acoustics, Frequency Domain (ta)**.
- 4 Find the **Studies** subsection. In the **Select Study** tree, select **General Studies>Stationary**.
- 5 Click **Add Study** in the window toolbar.

## STUDY 1 - VENT EXPOSED

- 1 In the **Model Builder** window, click **Study 1**.
- 2 In the **Settings** window for **Study**, type Study 1 - Vent Exposed in the **Label** text field.
- 3 Locate the **Study Settings** section. Clear the **Generate default plots** check box.

### *Frequency Domain Perturbation*

- 1 In the **Study** toolbar, click  **Study Steps** and choose **Frequency Domain>Frequency Domain Perturbation**.
- 2 In the **Settings** window for **Frequency Domain Perturbation**, locate the **Study Settings** section.
- 3 In the **Frequencies** text field, type  $10^{\{\text{range}(0, 3/10, 3)\}} \cdot 10^{\{\text{range}(3.3, 1/20, 4.3)\}}$ .  
This will give you 10 frequencies on a logarithmic scale from 1 Hz to 1 kHz and further 20 frequencies from approximately 2 kHz to 20 kHz.
- 4 Locate the **Physics and Variables Selection** section. Select the **Modify model configuration for study step** check box.
- 5 In the tree, select **Component 1 (comp1)>Thermoviscous Acoustics, Frequency Domain (ta)>Pressure (Adiabatic) 2**.
- 6 Right-click and choose **Disable**.

### *Solution 1 (sol1)*

- 1 In the **Study** toolbar, click  **Show Default Solver**.
- 2 In the **Model Builder** window, expand the **Solution 1 (sol1)** node.
- 3 In the **Model Builder** window, expand the **Study 1 - Vent Exposed>Solver Configurations>Solution 1 (sol1)>Stationary Solver 1** node.
- 4 Right-click **Study 1 - Vent Exposed>Solver Configurations>Solution 1 (sol1)>Stationary Solver 1** and choose **Fully Coupled**.

- 5 Right-click **Study 1 - Vent Exposed>Solver Configurations>Solution 1 (sol1)>Stationary Solver 1>Direct** and choose **Enable**.
- 6 In the **Model Builder** window, expand the **Study 1 - Vent Exposed>Solver Configurations>Solution 1 (sol1)>Stationary Solver 2** node, then click **Direct 1**.
- 7 In the **Settings** window for **Direct**, locate the **General** section.
- 8 From the **Solver** list, choose **PARDISO**.  
Solve the model for the case where the vent is exposed to the incoming signal  $P_{in}$ . Solving the model for all the desired frequencies may take up to 15 min.
- 9 In the **Study** toolbar, click  **Compute**.  
Set up a second study for the unexposed vent case, where  $P_{vent} = 0$  Pa. The procedure is the same as for setting up the first study. Disable the first pressure boundary condition so that only the unvented case is treated.

#### ADD STUDY

- 1 Go to the **Add Study** window.
- 2 Find the **Physics interfaces in study** subsection. In the table, clear the **Solve** check box for **Thermoviscous Acoustics, Frequency Domain (ta)**.
- 3 Find the **Studies** subsection. In the **Select Study** tree, select **General Studies>Stationary**.
- 4 Click **Add Study** in the window toolbar.
- 5 In the **Study** toolbar, click  **Add Study** to close the **Add Study** window.

#### STUDY 2 - VENT UNEXPOSED

- 1 In the **Model Builder** window, click **Study 2**.
- 2 In the **Settings** window for **Study**, type Study 2 - Vent Unexposed in the **Label** text field.
- 3 Locate the **Study Settings** section. Clear the **Generate default plots** check box.



#### *Frequency Domain Perturbation*

- 1 In the **Study** toolbar, click  **Study Steps** and choose **Frequency Domain>Frequency Domain Perturbation**.
- 2 In the **Settings** window for **Frequency Domain Perturbation**, locate the **Study Settings** section.
- 3 In the **Frequencies** text field, type  $10^{\{\text{range}(0, 3/10, 3)\}} 10^{\{\text{range}(3.3, 1/20, 4.3)\}}$ .

This gives 10 frequencies on a logarithmic scale from 1 Hz to 1 kHz.

- 4 Locate the **Physics and Variables Selection** section. Select the **Modify model configuration for study step** check box.
- 5 In the tree, select **Component 1 (comp1)>Thermoviscous Acoustics, Frequency Domain (ta)>Pressure (Adiabatic) 1**.
- 6 Right-click and choose **Disable**.

#### *Solution 3 (sol3)*

- 1 In the **Study** toolbar, click  **Show Default Solver**.
- 2 In the **Model Builder** window, expand the **Solution 3 (sol3)** node.
- 3 In the **Model Builder** window, expand the **Study 2 - Vent Unexposed>Solver Configurations>Solution 3 (sol3)>Stationary Solver 1** node.
- 4 Right-click **Study 2 - Vent Unexposed>Solver Configurations>Solution 3 (sol3)>Stationary Solver 1** and choose **Fully Coupled**.
- 5 Right-click **Study 2 - Vent Unexposed>Solver Configurations>Solution 3 (sol3)>Stationary Solver 1>Direct** and choose **Enable**.
- 6 In the **Model Builder** window, expand the **Study 2 - Vent Unexposed>Solver Configurations>Solution 3 (sol3)>Stationary Solver 2** node, then click **Direct 1**.
- 7 In the **Settings** window for **Direct**, locate the **General** section.
- 8 From the **Solver** list, choose **PARDISO**.  
Solve the model for the case where the vent is unexposed to the incoming signal  $P_{in}$ .
- 9 In the **Study** toolbar, click  **Compute**.

## **RESULTS**

Four datasets have been created automatically:

- Study 1 - Vent Exposed/Solution 1 contains the full solution of the exposed.
- Study 1 - Vent Exposed/Solution Store 1 contains the stationary solution, that is, the linearization point, for Study 1.
- Study 2 - Vent Unexposed/Solution 3 contains the full solution of the unexposed vent configuration.
- Study 2 - Vent Unexposed/Solution Store 2 contains the stationary solution for Study 2.

Create a Sector 3D dataset to visualize the full geometry.

### *Study 1 - Vent Exposed/Solution 1 (sol1)*



- 1 In the **Model Builder** window, expand the **Results>Datasets** node, then click **Study 1 - Vent Exposed/Solution 1 (sol1)**.
- 2 In the **Settings** window for **Solution**, locate the **Solution** section.
- 3 From the **Frame** list, choose **Material (X, Y, Z)**.

### *Sector 3D 1*

- 1 In the **Results** toolbar, click  **More Datasets** and choose **Sector 3D**.
- 2 In the **Settings** window for **Sector 3D**, locate the **Symmetry** section.
- 3 In the **Number of sectors** text field, type 12.
- 4 From the **Transformation** list, choose **Rotation and reflection**.
- 5 Find the **Radial direction of reflection plane** subsection. In the **X** text field, type 0.
- 6 In the **Y** text field, type -1.

Evaluate the stationary terminal voltage to see if it is equal to the polarization voltage  $V_{pol} = 200$  V as expected.

### *Global Evaluation 1*

- 1 In the **Results** toolbar, click  **Global Evaluation**.
- 2 In the **Settings** window for **Global Evaluation**, click **Replace Expression** in the upper-right corner of the **Expressions** section. From the menu, choose **Component 1 (comp1)>Electrostatics>Terminals>es.V0\_1 - Terminal voltage - V**.
- 3 Locate the **Expressions** section. From the **Expression evaluated for** list, choose **Static solution**.
- 4 Click  **Evaluate**.

Next, set up 3D plots to visualize the solution in the computational domain, including membrane deformation, particle velocity, sound pressure levels, acoustic temperature variations, and the static electric potential.

### *Membrane Deformation*

- 1 In the **Results** toolbar, click  **3D Plot Group**.
- 2 In the **Settings** window for **3D Plot Group**, type Membrane Deformation in the **Label** text field.
- 3 Locate the **Data** section. From the **Dataset** list, choose **Sector 3D 1**.
- 4 Locate the **Color Legend** section. Select the **Show units** check box.



### *Surface 1*

- 1 Right-click **Membrane Deformation** and choose **Surface**.



- 2 In the **Settings** window for **Surface**, locate the **Expression** section.
- 3 In the **Expression** text field, type `mbrn.disp`.
- 4 From the **Unit** list, choose **µm**.

#### *Deformation I*

- 1 Right-click **Surface I** and choose **Deformation**.
- 2 In the **Membrane Deformation** toolbar, click  **Plot**.
- 3 Click the  **Zoom Extents** button in the **Graphics** toolbar.

#### *Membrane Deformation*

The plot should look like the one in [Figure 5](#) top.

Change the evaluation frequency to 1000 Hz.

- 1 In the **Model Builder** window, under **Results** click **Membrane Deformation**.
  - 2 In the **Settings** window for **3D Plot Group**, locate the **Data** section.
  - 3 From the **Parameter value (freq (Hz))** list, choose **1000**.
  - 4 In the **Membrane Deformation** toolbar, click  **Plot**.
- The plot should look like the one in [Figure 5](#) bottom.

#### *Velocity*

- 1 In the **Home** toolbar, click  **Add Plot Group** and choose **3D Plot Group**.
- 2 In the **Settings** window for **3D Plot Group**, type **Velocity** in the **Label** text field.
- 3 Locate the **Color Legend** section. Select the **Show units** check box.

#### *Slice I*

- 1 Right-click **Velocity** and choose **Slice**.
- 2 In the **Settings** window for **Slice**, locate the **Expression** section.
- 3 In the **Expression** text field, type `ta.v_inst`.
- 4 Locate the **Plane Data** section. From the **Plane** list, choose **ZX-planes**.

5 In the **Velocity** toolbar, click  **Plot**.

The plot shows the instantaneous velocity amplitude. Possibly zoom to the area near the backplate perforation and the membrane to see the highest amplitudes.

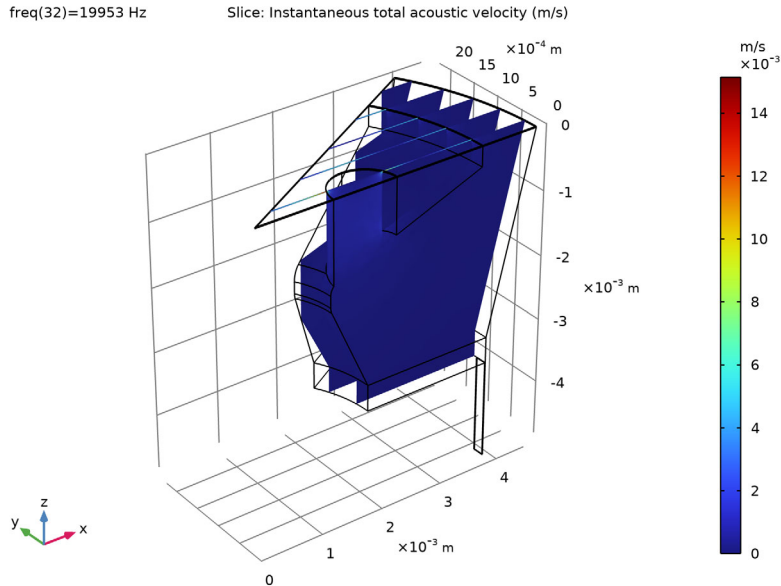

#### Sound Pressure Level

- 1 In the **Home** toolbar, click  **Add Plot Group** and choose **3D Plot Group**.
- 2 In the **Settings** window for **3D Plot Group**, type Sound Pressure Level in the **Label** text field.
- 3 Locate the **Color Legend** section. Select the **Show units** check box.

#### Surface 1

- 1 Right-click **Sound Pressure Level** and choose **Surface**.
- 2 In the **Settings** window for **Surface**, locate the **Expression** section.
- 3 In the **Expression** text field, type  $ta.Lp_t$ .

- 4 In the **Sound Pressure Level** toolbar, click  **Plot**.

The sound pressure level distribution inside the microphone is seen here.

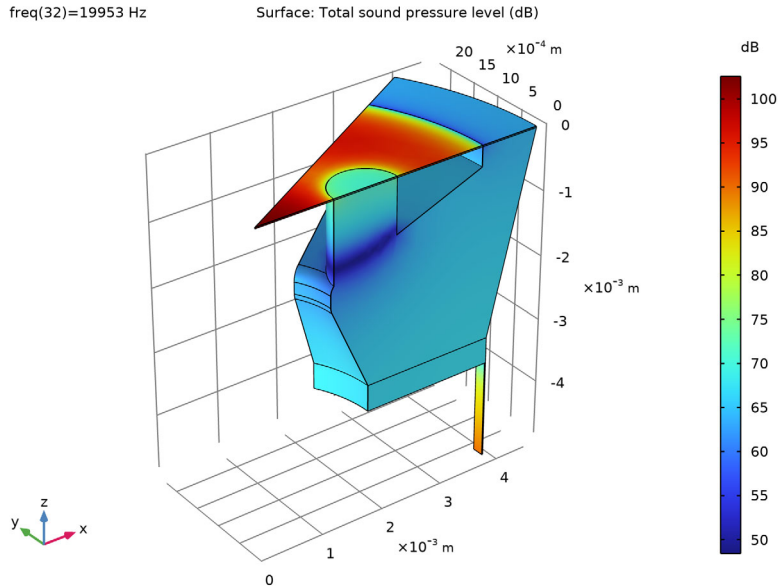

#### *Acoustic Temperature Variation*

- 1 In the **Home** toolbar, click  **Add Plot Group** and choose **3D Plot Group**.
- 2 In the **Settings** window for **3D Plot Group**, type **Acoustic Temperature Variation** in the **Label** text field.
- 3 Locate the **Data** section. From the **Parameter value (freq (Hz))** list, choose **1000**.
- 4 Locate the **Color Legend** section. Select the **Show units** check box.

#### *Surface 1*

- 1 Right-click **Acoustic Temperature Variation** and choose **Surface**.
- 2 In the **Settings** window for **Surface**, locate the **Expression** section.
- 3 In the **Expression** text field, type **ta.T\_t**.
- 4 From the **Unit** list, choose **mK**.
- 5 Locate the **Coloring and Style** section. From the **Color table** list, choose **ThermalWave**.
- 6 From the **Scale** list, choose **Linear symmetric**.

7 In the **Acoustic Temperature Variation** toolbar, click  **Plot**.

The acoustic temperature variation  $\tau_a \cdot T_t$  inside the microphone is here seen at 1000 Hz. The thermal boundary layer is clearly visible. If you change the evaluation frequency to a lower value you can study the transition to the isothermal behavior. Here  $T$  is nearly constant and 0 inside the microphone (note the min/max numerical values on the color bar).

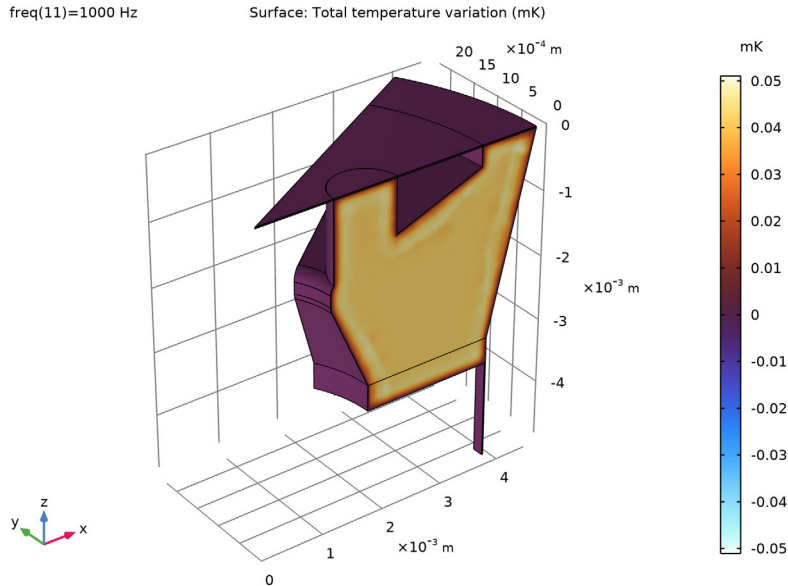

*Electric Potential (stationary)*

- 1 In the **Home** toolbar, click  **Add Plot Group** and choose **3D Plot Group**.
- 2 In the **Settings** window for **3D Plot Group**, type **Electric Potential (stationary)** in the **Label** text field.
- 3 Locate the **Data** section. From the **Dataset** list, choose **Sector 3D I**.
- 4 Locate the **Color Legend** section. Select the **Show units** check box.

*Multislice 1*

- 1 In the **Electric Potential (stationary)** toolbar, click  **More Plots** and choose **Multislice**.
- 2 In the **Settings** window for **Multislice**, locate the **Expression** section.
- 3 In the **Expression** text field, type  $V$ .
- 4 From the **Expression evaluated for** list, choose **Static solution**.

- 5 Locate the **Multipane Data** section. Find the **Z-planes** subsection. In the **Planes** text field, type 3.
- 6 Locate the **Coloring and Style** section. From the **Color table** list, choose **Dipole**.
- 7 In the **Electric Potential (stationary)** toolbar, click  **Plot**.  
The plot should look like the one in [Figure 6](#).  
Now, create three 1D plots to visualize the microphone sensitivity, membrane deformation, and Maxwell stresses.

#### *Sensitivity*

- 1 In the **Home** toolbar, click  **Add Plot Group** and choose **1D Plot Group**.
- 2 In the **Settings** window for **1D Plot Group**, type **Sensitivity** in the **Label** text field.
- 3 Click to expand the **Title** section. From the **Title type** list, choose **Label**.
- 4 Locate the **Plot Settings** section.
- 5 Select the **x-axis label** check box. In the associated text field, type  $f$  (Hz).
- 6 Select the **y-axis label** check box. In the associated text field, type  $\text{dB (rel. } 1 \text{ V/Pa)}$ .
- 7 Locate the **Legend** section. From the **Position** list, choose **Lower right**.

#### *Global 1*

- 1 Right-click **Sensitivity** and choose **Global**.
- 2 In the **Settings** window for **Global**, locate the **y-Axis Data** section.
- 3 In the table, enter the following settings:

Expression	Unit	Description
$20 \cdot \log_{10}(\text{abs}(\text{es.V0}_1/\text{pin}))+L0$		Model (vent exposed)
$\text{int\_ave}(\text{freq})$		Average measurement
$\text{int\_min}(\text{freq})$		Lower measurement
$\text{int\_max}(\text{freq})$		Upper measurement

- 4 In the **Sensitivity** toolbar, click  **Plot**.
- 5 Click the  **x-Axis Log Scale** button in the **Graphics** toolbar.

#### *Global 2*

- 1 In the **Model Builder** window, right-click **Sensitivity** and choose **Global**.
- 2 In the **Settings** window for **Global**, locate the **Data** section.
- 3 From the **Dataset** list, choose **Study 2 - Vent Unexposed/Solution 3 (sol3)**.

4 Locate the **y-Axis Data** section. In the table, enter the following settings:

Expression	Unit	Description
$20 \cdot \log_{10}(\text{abs}(es.V0\_1/pin)) + L0$		Model (vent unexposed)

5 In the **Sensitivity** toolbar, click  **Plot**.

The plot of the microphone sensitivity should look like the one in [Figure 4](#).

#### *Static Membrane Deformation*

- 1 In the **Home** toolbar, click  **Add Plot Group** and choose **ID Plot Group**.
- 2 In the **Settings** window for **ID Plot Group**, type Static Membrane Deformation in the **Label** text field.
- 3 Locate the **Title** section. From the **Title type** list, choose **Label**.

#### *Line Graph 1*

- 1 Right-click **Static Membrane Deformation** and choose **Line Graph**.
- 2 In the **Settings** window for **Line Graph**, locate the **y-Axis Data** section.
- 3 In the **Expression** text field, type  $w_m$ .
- 4 Select Edges 4, 25, 44, and 59 only.
- 5 From the **Expression evaluated for** list, choose **Static solution**.

#### *Line Graph 2*

- 1 In the **Model Builder** window, right-click **Static Membrane Deformation** and choose **Line Graph**.
- 2 In the **Settings** window for **Line Graph**, locate the **y-Axis Data** section.
- 3 In the **Expression** text field, type  $w_m$ .
- 4 Select Edges 5 and 51 only.
- 5 From the **Expression evaluated for** list, choose **Static solution**.

6 In the **Static Membrane Deformation** toolbar, click  **Plot**.

The figure below shows the static deformation of the membrane due to the pre-polarization, plotted along the two symmetry boundaries. Note the small difference in the curves due to the presence of the hole in the backplate.

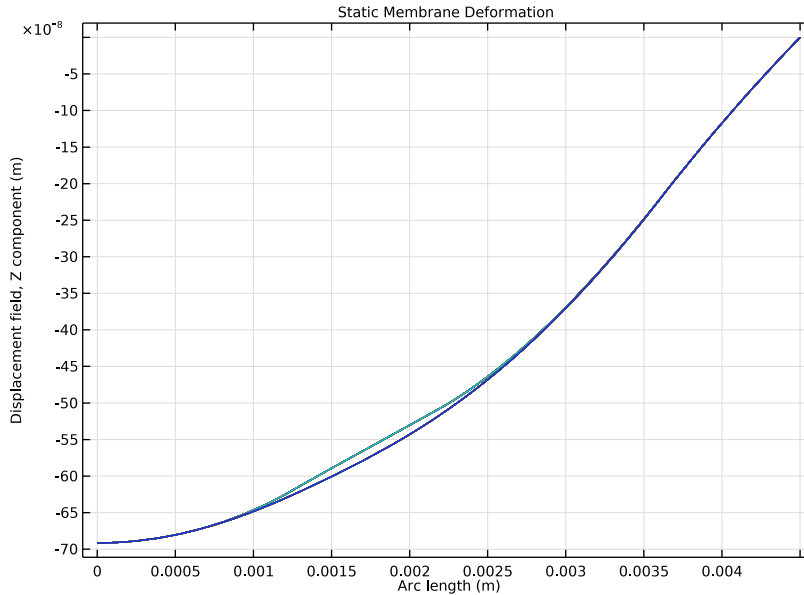

### Maxwell Stress

- 1 Right-click **Static Membrane Deformation** and choose **Duplicate**.
- 2 In the **Settings** window for **ID Plot Group**, type Maxwell Stress in the **Label** text field.

### Line Graph 1

- 1 In the **Model Builder** window, expand the **Maxwell Stress** node, then click **Line Graph 1**.
- 2 In the **Settings** window for **Line Graph**, locate the **y-Axis Data** section.
- 3 In the **Expression** text field, type `es.dnTz`.

### Line Graph 2

- 1 In the **Model Builder** window, click **Line Graph 2**.
- 2 In the **Settings** window for **Line Graph**, locate the **y-Axis Data** section.
- 3 In the **Expression** text field, type `es.dnTz`.

- 4 In the **Maxwell Stress** toolbar, click  **Plot**.

This figure depicts the static electric surface forces (Maxwell stresses) acting on the membrane due to the pre-polarization. Again notice the difference in the two curves, which is due to the presence of the hole in the backplate.

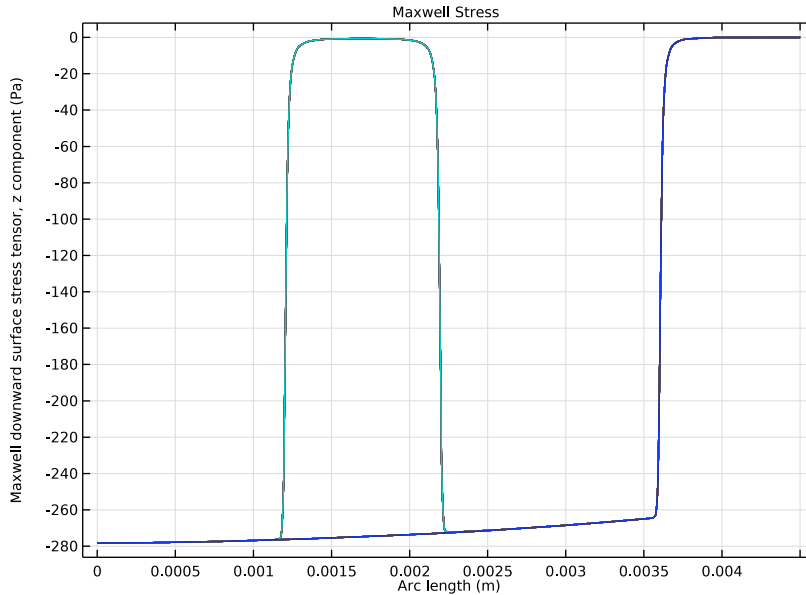

Finally, reproduce the sensitivity curve in 1/3 octave bands (in the exposed vent configuration) using the Octave Band plot.

#### *Sensitivity, 1/3 Octave Bands*

- 1 In the **Home** toolbar, click  **Add Plot Group** and choose **ID Plot Group**.
- 2 In the **Settings** window for **ID Plot Group**, type **Sensitivity, 1/3 Octave Bands** in the **Label** text field.
- 3 Locate the **Title** section. From the **Title type** list, choose **Label**.

#### *Octave Band 1*

- 1 In the **Sensitivity, 1/3 Octave Bands** toolbar, click  **More Plots** and choose **Octave Band**.
- 2 In the **Settings** window for **Octave Band**, locate the **Selection** section.
- 3 From the **Geometric entity level** list, choose **Global**.
- 4 Locate the **y-Axis Data** section. From the **Expression type** list, choose **Transfer function**.



- 5 In the **Level reference** text field, type L0.
- 6 In the **Expression** text field, type  $\text{abs}(es.v0\_1/pin)^2$ .  
The expression represents the power transfer function H from the incident pressure to measured voltage.
- 7 Locate the **Plot** section. From the **Quantity** list, choose **Band average power spectral density**.
- 8 From the **Band type** list, choose **1/3 octave**.
- 9 In the **Sensitivity, 1/3 Octave Bands** toolbar, click  **Plot**.

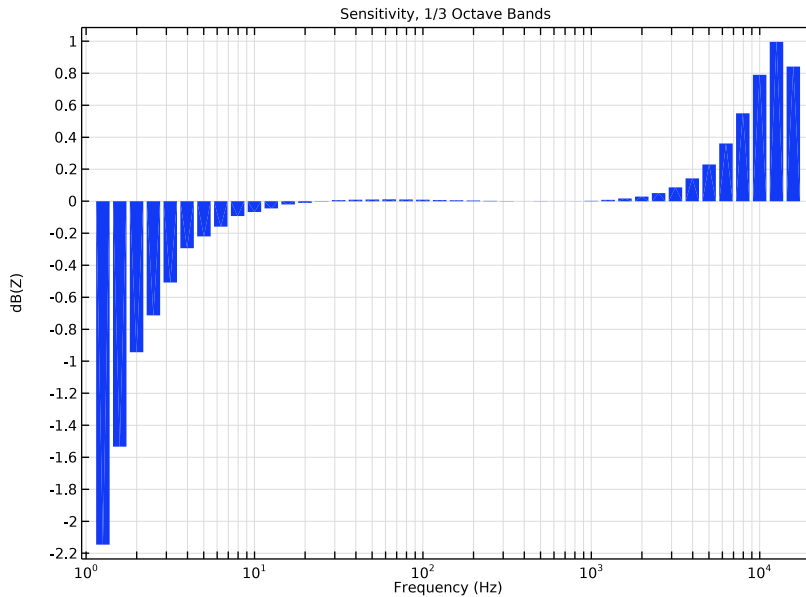

## DEFINITIONS

Now, proceed and postprocess the mechanical-thermal noise of the microphone. First, load some variables and set up two integration operators. The plots and a discussion of the results are presented at the end of the Results and Discussion section.

### Integration 1 (intop1)

- 1 In the **Definitions** toolbar, click  **Nonlocal Couplings** and choose **Integration**.
- 2 In the **Settings** window for **Integration**, type intop\_vo1 in the **Operator name** text field.
- 3 Locate the **Source Selection** section. From the **Selection** list, choose **All domains**.

### *Integration 2 (intop2)*

- 1 In the **Definitions** toolbar, click  **Nonlocal Couplings** and choose **Integration**.
- 2 In the **Settings** window for **Integration**, type intop\_mem in the **Operator name** text field.
- 3 Locate the **Source Selection** section. From the **Geometric entity level** list, choose **Boundary**.
- 4 From the **Selection** list, choose **Membrane**.

### *Variables 1*

- 1 In the **Model Builder** window, right-click **Definitions** and choose **Variables**.
- 2 In the **Settings** window for **Variables**, locate the **Variables** section.
- 3 Click  **Load from File**.
- 4 Browse to the model's Application Libraries folder and double-click the file bk\_4134\_microphone\_variables.txt.

## **STUDY 2 - VENT UNEXPOSED**

Update the solution in **Study 2** so that the new variables and integration operators are present for postprocessing.

In the **Study** toolbar, click  **Update Solution**.

## **RESULTS**

### *Dissipated Energy*

- 1 In the **Home** toolbar, click  **Add Plot Group** and choose **ID Plot Group**.
- 2 In the **Settings** window for **ID Plot Group**, type Dissipated Energy in the **Label** text field.
- 3 Locate the **Data** section. From the **Dataset** list, choose **Study 2 - Vent Unexposed/Solution 3 (sol3)**.
- 4 Locate the **Title** section. From the **Title type** list, choose **Label**.
- 5 Locate the **Plot Settings** section.
- 6 Select the **x-axis label** check box. In the associated text field, type  $f$  (Hz).
- 7 Select the **y-axis label** check box. In the associated text field, type  $P$  (W).
- 8 Locate the **Axis** section. Select the **x-axis log scale** check box.
- 9 Select the **y-axis log scale** check box.
- 10 Locate the **Legend** section. From the **Position** list, choose **Upper left**.

### Global 1

- 1 Right-click **Dissipated Energy** and choose **Global**.
- 2 In the **Settings** window for **Global**, locate the **y-Axis Data** section.
- 3 In the table, enter the following settings:

Expression	Unit	Description
Ptot	W	Total thermal and viscous dissipated power
Pvisc	W	Viscous dissipated power
Ptherm	W	Thermal dissipated power

- 4 In the **Dissipated Energy** toolbar, click  **Plot**.

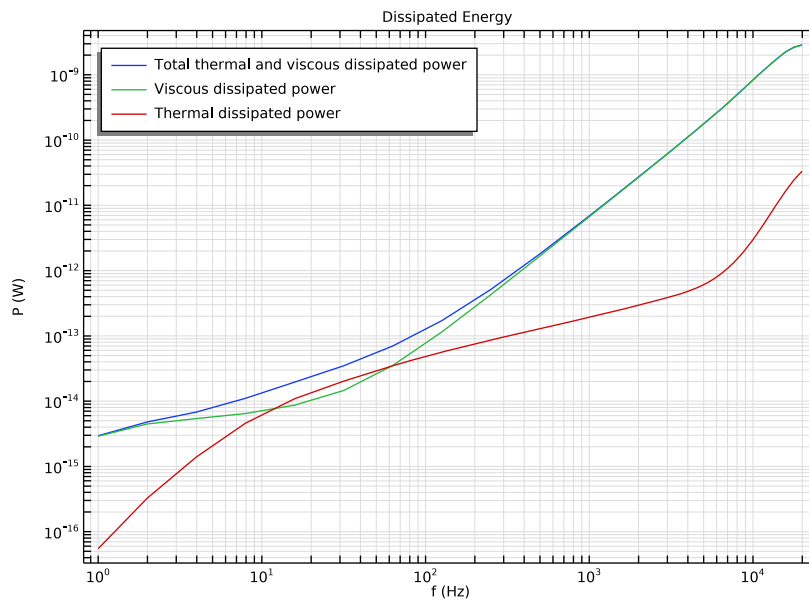

### Equivalent Acoustic Resistance

- 1 In the **Home** toolbar, click  **Add Plot Group** and choose **ID Plot Group**.
- 2 In the **Settings** window for **ID Plot Group**, type Equivalent Acoustic Resistance in the **Label** text field.
- 3 Locate the **Data** section. From the **Dataset** list, choose **Study 2 - Vent Unexposed/ Solution 3 (sol3)**.
- 4 Locate the **Plot Settings** section.
- 5 Select the **x-axis label** check box. In the associated text field, type  $f$  (Hz).

- 6 Select the **y-axis label** check box. In the associated text field, type  $R = \text{real}(Z)$  ( $\text{kg}/(\text{m}^4 \cdot \text{s})$ ).
- 7 Locate the **Axis** section. Select the **x-axis log scale** check box.
- 8 Select the **y-axis log scale** check box.

*Global 1*

- 1 Right-click **Equivalent Acoustic Resistance** and choose **Global**.
- 2 In the **Settings** window for **Global**, locate the **y-Axis Data** section.
- 3 In the table, enter the following settings:

Expression	Unit	Description
$\text{real}(-p_{in}/Q_{mem})$	$\text{kg}/(\text{m}^4 \cdot \text{s})$	$\text{real}(Z)$

*Global 2*

- 1 In the **Model Builder** window, right-click **Equivalent Acoustic Resistance** and choose **Global**.

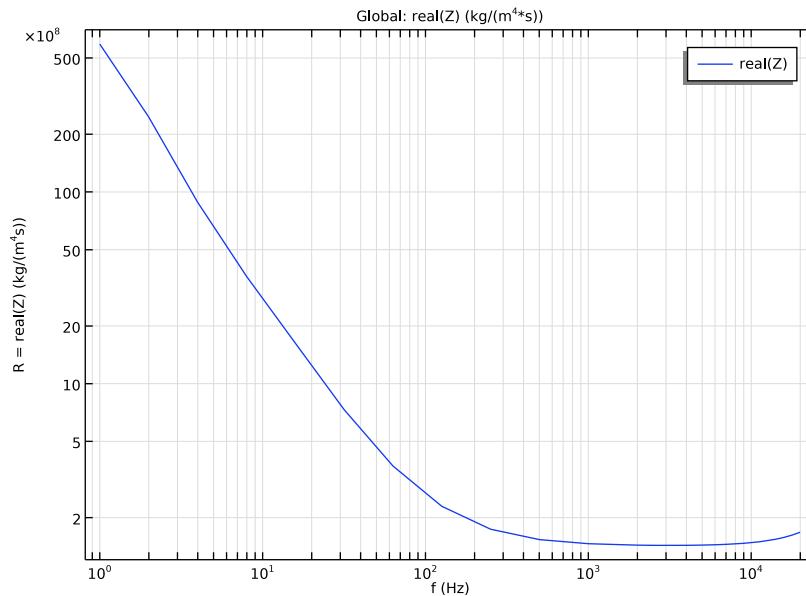

- 2 In the **Settings** window for **Global**, locate the **y-Axis Data** section.

3 In the table, enter the following settings:

Expression	Unit	Description
$P_{tot}/(0.5*abs(Q_{mem})^2)$	kg/(m <sup>4</sup> *s)	real(Z) - total dissipated power
$P_{visc}/(0.5*abs(Q_{mem})^2)$	kg/(m <sup>4</sup> *s)	real(Z) - viscous dissipated power
$P_{therm}/(0.5*abs(Q_{mem})^2)$	kg/(m <sup>4</sup> *s)	real(Z) - thermal dissipated power

4 Click to expand the **Coloring and Style** section. Find the **Line style** subsection. From the **Line** list, choose **None**.

5 Find the **Line markers** subsection. From the **Marker** list, choose **Point**.

6 From the **Positioning** list, choose **In data points**.

7 In the **Equivalent Acoustic Resistance** toolbar, click  **Plot**.

#### *Noise Power Spectral Density*

1 In the **Home** toolbar, click  **Add Plot Group** and choose **ID Plot Group**.

2 In the **Settings** window for **ID Plot Group**, type Noise Power Spectral Density in the **Label** text field.

3 Locate the **Data** section. From the **Dataset** list, choose **Study 2 - Vent Unexposed/Solution 3 (sol3)**.

4 Locate the **Title** section. From the **Title type** list, choose **Label**.

5 Locate the **Plot Settings** section.

6 Select the **x-axis label** check box. In the associated text field, type  $f$  (Hz).

7 Select the **y-axis label** check box. In the associated text field, type Power Spectral Density (Pa<sup>2</sup>/Hz).

8 Locate the **Axis** section. Select the **x-axis log scale** check box.

9 Select the **y-axis log scale** check box.

10 Locate the **Legend** section. Clear the **Show legends** check box.

#### *Global 1*

1 Right-click **Noise Power Spectral Density** and choose **Global**.

2 In the **Settings** window for **Global**, locate the **y-Axis Data** section.

3 In the table, enter the following settings:

Expression	Unit	Description
$4 * k_B \cdot \text{const} * T_0 * \text{real}(-p_{in}/Q_{mem}) * 1$ [Hz]	$\text{kg}^2 / (\text{m}^2 * \text{s}^4)$	

4 In the **Noise Power Spectral Density** toolbar, click  **Plot**.

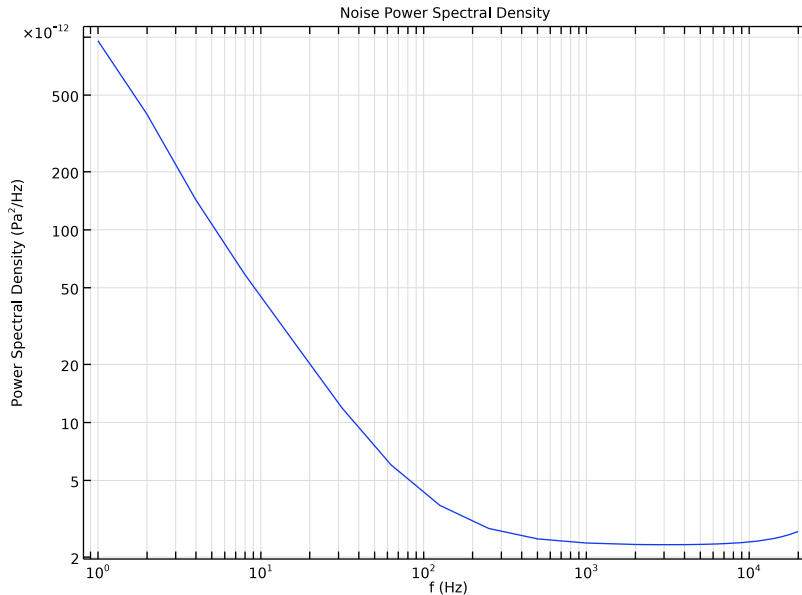

#### Noise Pressure Spectral Density

- 1 In the **Home** toolbar, click  **Add Plot Group** and choose **ID Plot Group**.
- 2 In the **Settings** window for **ID Plot Group**, type Noise Pressure Spectral Density in the **Label** text field.
- 3 Locate the **Data** section. From the **Dataset** list, choose **Study 2 - Vent Unexposed/ Solution 3 (sol3)**.
- 4 Locate the **Title** section. From the **Title type** list, choose **Label**.
- 5 Locate the **Plot Settings** section.
- 6 Select the **x-axis label** check box. In the associated text field, type  $f$  (Hz).
- 7 Select the **y-axis label** check box. In the associated text field, type Pressure Spectral Density (Pa/Hz<sup>1/2</sup>).
- 8 Locate the **Axis** section. Select the **x-axis log scale** check box.

- 9 Select the **y-axis log scale** check box.
- 10 Locate the **Legend** section. Clear the **Show legends** check box.

*Global 1*

- 1 Right-click **Noise Pressure Spectral Density** and choose **Global**.
- 2 In the **Settings** window for **Global**, locate the **y-Axis Data** section.
- 3 In the table, enter the following settings:

Expression	Unit	Description
$\text{sqrt}(4*k\_B\_const*T0*\text{real}(-\text{pin}/Q\text{mem})*1[\text{Hz}])$	J/m <sup>3</sup>	

- 4 In the **Noise Pressure Spectral Density** toolbar, click  **Plot**.

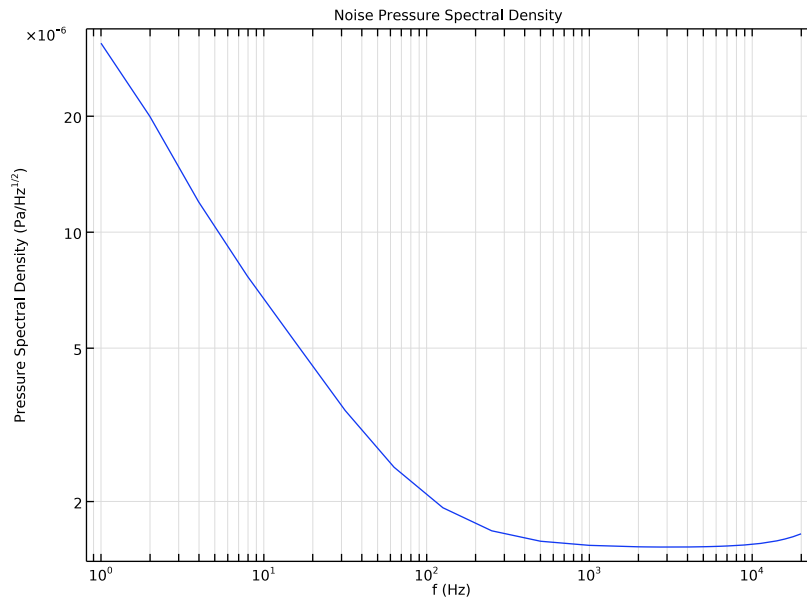

*Noise Floor Level*

- 1 In the **Home** toolbar, click  **Add Plot Group** and choose **ID Plot Group**.
- 2 In the **Settings** window for **ID Plot Group**, type **Noise Floor Level1** in the **Label** text field.
- 3 Locate the **Data** section. From the **Dataset** list, choose **Study 2 - Vent Unexposed/ Solution 3 (sol3)**.
- 4 Locate the **Title** section. From the **Title type** list, choose **Label**.

- 5 Locate the **Plot Settings** section.
- 6 Select the **x-axis label** check box. In the associated text field, type  $f$  (Hz).
- 7 Select the **y-axis label** check box. In the associated text field, type Level (dB SPL).
- 8 Locate the **Axis** section. Select the **x-axis log scale** check box.
- 9 Locate the **Legend** section. Clear the **Show legends** check box.

*Global 1*

- 1 Right-click **Noise Floor Level** and choose **Global**.
- 2 In the **Settings** window for **Global**, locate the **y-Axis Data** section.
- 3 In the table, enter the following settings:

Expression	Unit	Description
$10 \cdot \log_{10}(4 \cdot k_B \cdot \text{const} \cdot T_0 \cdot \text{real}(-\text{pin}/Q_{\text{mem}}) \cdot 1[\text{Hz}] / (20[\text{uPa}])^2)$		

- 4 In the **Noise Floor Level** toolbar, click  **Plot**.

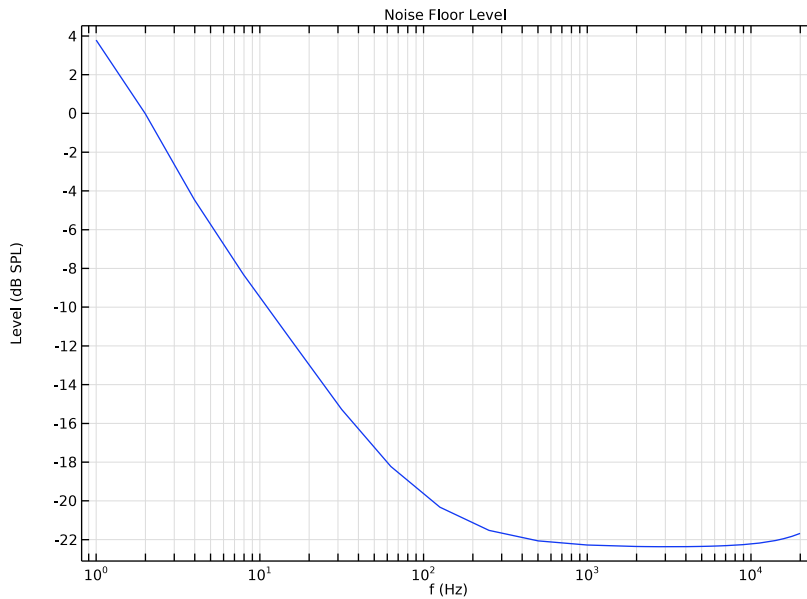



*Dissipated Energy, Equivalent Acoustic Resistance, Noise Floor Level, Noise Power Spectral Density, Noise Pressure Spectral Density*

**1** In the **Model Builder** window, under **Results**, Ctrl-click to select **Dissipated Energy**, **Equivalent Acoustic Resistance**, **Noise Power Spectral Density**, **Noise Pressure Spectral Density**, and **Noise Floor Level**.

**2** Right-click and choose **Group**.

*Mechanical-Thermal Noise Plots*

In the **Settings** window for **Group**, type Mechanical-Thermal Noise Plots in the **Label** text field.

