



Inductance Matrix Calculation of PCB Coils

Introduction

PCB (printed-circuit board) coils are widely used in a variety of industrial applications such as micromotor and microelectronic devices. For an array of PCB coils, it is generally of interest to know the inductive coupling represented by the inductance matrix. This model demonstrates how to use the Magnetic Fields, Currents Only interface to compute the inductance matrix of an array of coils in a multilayer PCB, as shown in [Figure 1](#).

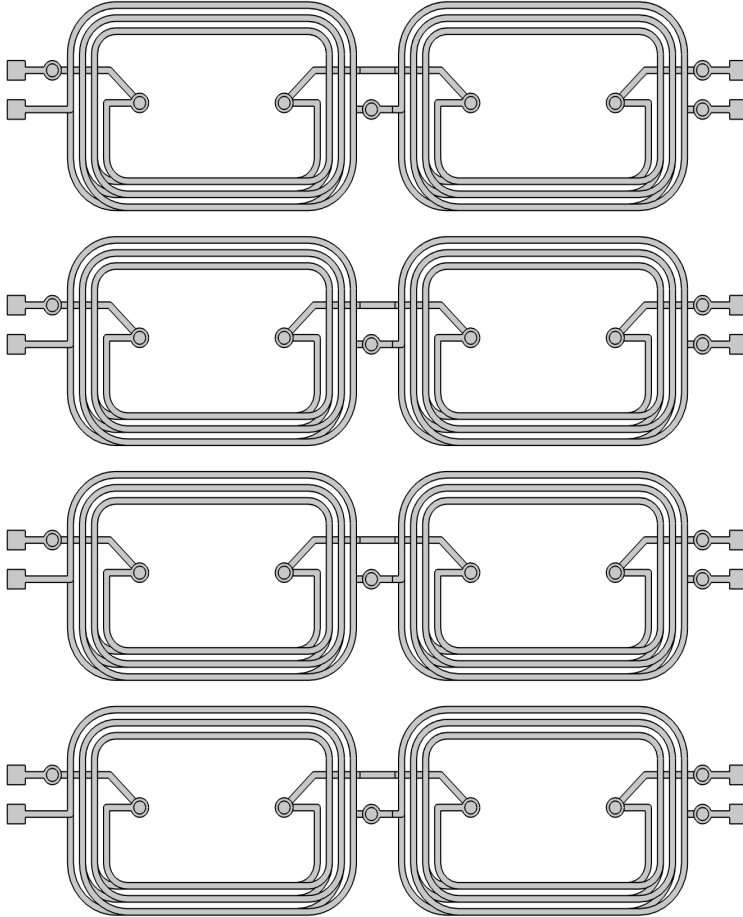

Figure 1: The geometry of PCB coils.

Model Definition

The geometry of the coils is usually ‘open’; the modeling of a closed current loop is not of interest and is also not necessary. The Magnetic Fields, Currents Only interface can model such nondivergence-free currents. For more details, see *Theory for the Magnetic Fields, Currents Only Interface* in the *AC/DC Module User’s Guide*.

The PCB coils are modeled by the **Conductor** feature, which can be used to easily set up the current sources. With using the **Split by Connectivity** functionality, 12 coils can be automatically identified and the corresponding **Conductor** features are created. This greatly simplifies the steps to set up the physics interface. The model is solved with a **Stationary Source Sweep** with **Initialization** study, as well as with a **Frequency Domain Source Sweep** with **Initialization** study. Both of these are dedicated to computing the lumped inductance matrix.

Results and Discussion

Figure 2 shows the distribution of the magnetic flux density norm around the PCB coils when the 8th conductor is activated, in the stationary case. Figure 3 illustrates the corresponding inductance matrix of the PCB coils. Similar plots for the frequency domain solution, are shown in Figure 4 and Figure 5, respectively.

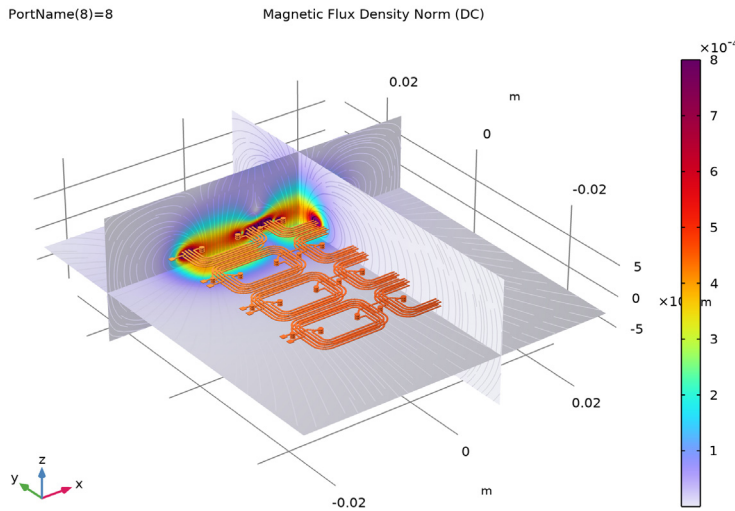

Figure 2: The distribution of the magnetic flux density norm around PCB coils, stationary solution.

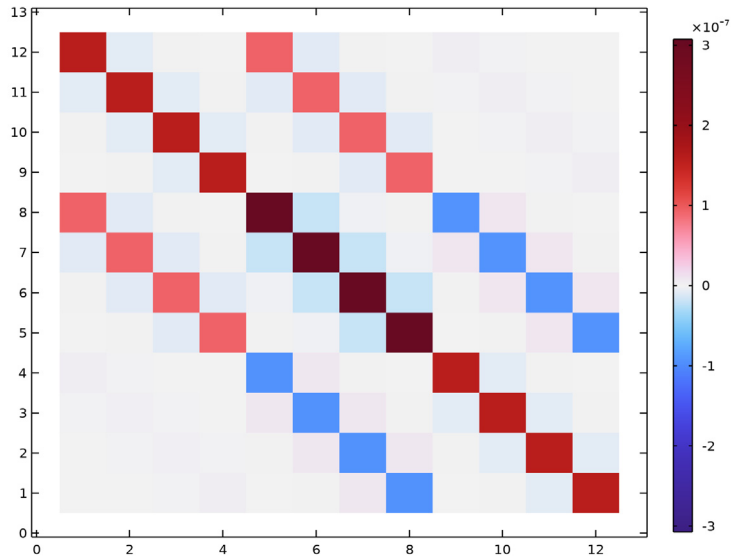

Figure 3: Visualization of the inductance matrix of PCB coils, stationary solution.

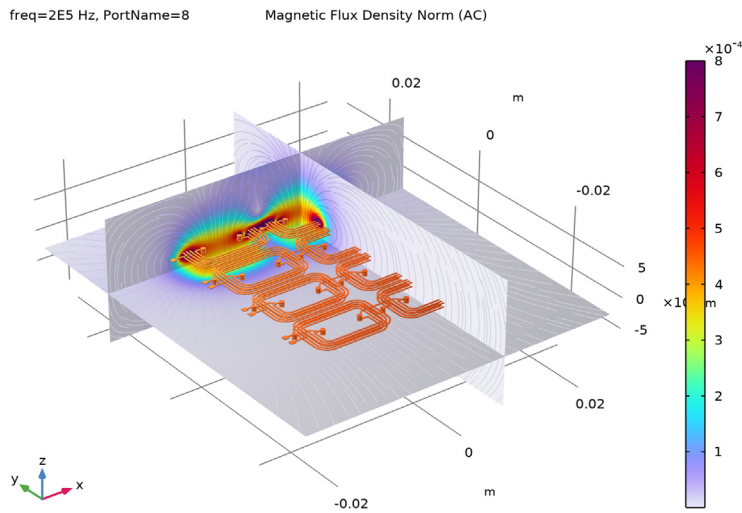

Figure 4: The distribution of the magnetic flux density norm around PCB coils, frequency domain solution.

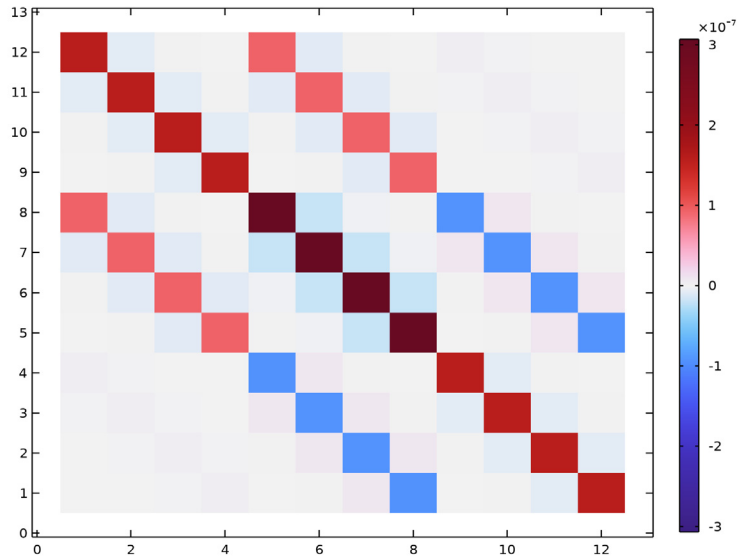



Figure 5: Visualization of the inductance matrix of PCB coils, frequency domain solution.

Application Library path: ACDC_Module/Inductive_Devices_and_Coils/
inductance_matrix_pcb_coils



Modeling Instructions

From the **File** menu, choose **New**.

NEW

In the **New** window, click  **Model Wizard**.

MODEL WIZARD

- 1 In the **Model Wizard** window, click  **3D**.
- 2 In the **Select Physics** tree, select **AC/DC>Electromagnetic Fields>Vector Formulations>Magnetic Fields, Currents Only (mfco)**.
- 3 Click **Add**.
- 4 Click  **Study**.

5 In the **Select Study** tree, select **Preset Studies for Selected Physics Interfaces> Stationary Source Sweep with Initialization**.

6 Click  **Done**.

GEOMETRY I

1 In the **Model Builder** window, under **Component 1 (comp1)** click **Geometry 1**.

2 In the **Settings** window for **Geometry**, locate the **Advanced** section.

3 From the **Geometry representation** list, choose **CAD kernel**.

Import 1 (imp1)

Since the geometry used for the model is quite complicated, we will import the coils from an existing file. Then we will manually add some blocks around these coils in the geometry, which will simplify the postprocessing.

1 In the **Home** toolbar, click  **Import**.

2 In the **Settings** window for **Import**, locate the **Import** section.

3 From the **Source** list, choose **COMSOL Multiphysics file**.

4 In the **Filename** text field, type `inductance_matrix_pcb_coils.mphbin`.

5 Click  **Import**.

6 Locate the **Selections of Resulting Entities** section. Select the **Resulting objects selection** check box.

7 From the **Show in physics** list, choose **All levels**.

8 Click the  **Transparency** button in the **Graphics** toolbar.

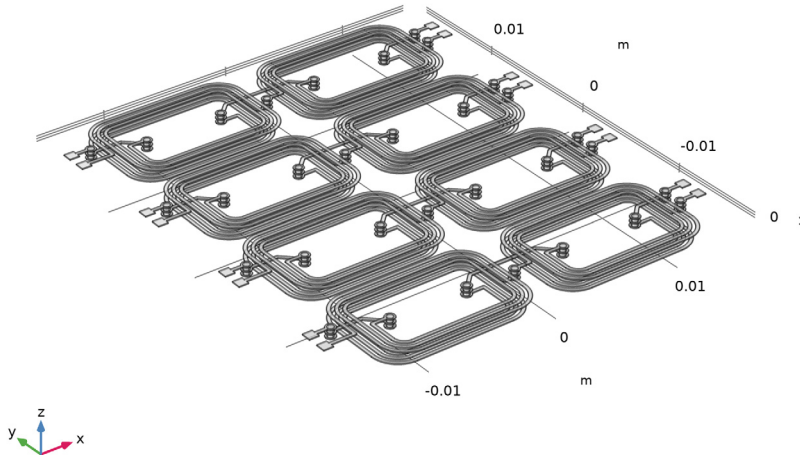

Block 1 (blk1)

- 1 In the **Geometry** toolbar, click  **Block**.
- 2 In the **Settings** window for **Block**, locate the **Size and Shape** section.
- 3 In the **Width** text field, type 5 [cm].
- 4 In the **Depth** text field, type 6 [cm].
- 5 In the **Height** text field, type 2 [cm].
- 6 Locate the **Position** section. From the **Base** list, choose **Center**.

Work Plane 1 (wp1)

- 1 In the **Geometry** toolbar, click  **Work Plane**.
- 2 In the **Settings** window for **Work Plane**, locate the **Plane Definition** section.
- 3 In the **z-coordinate** text field, type -2 [mm].

Partition Objects 1 (par1)

- 1 In the **Geometry** toolbar, click  **Booleans and Partitions** and choose **Partition Objects**.
- 2 Select the object **blk1** only.
- 3 In the **Settings** window for **Partition Objects**, locate the **Partition Objects** section.

4 From the **Partition with** list, choose **Work plane**.

Work Plane 2 (wp2)

1 In the **Geometry** toolbar, click  **Work Plane**.

2 In the **Settings** window for **Work Plane**, locate the **Plane Definition** section.

3 From the **Plane** list, choose **yz-plane**.

4 In the **x-coordinate** text field, type 7[mm].

Partition Objects 2 (par2)

1 In the **Geometry** toolbar, click  **Booleans and Partitions** and choose **Partition Objects**.

2 Select the object **par1** only.

3 In the **Settings** window for **Partition Objects**, locate the **Partition Objects** section.

4 From the **Partition with** list, choose **Work plane**.

Work Plane 3 (wp3)

1 In the **Geometry** toolbar, click  **Work Plane**.

2 In the **Settings** window for **Work Plane**, locate the **Plane Definition** section.

3 From the **Plane** list, choose **zx-plane**.

4 In the **y-coordinate** text field, type 14.25[mm].

Partition Objects 3 (par3)

1 In the **Geometry** toolbar, click  **Booleans and Partitions** and choose **Partition Objects**.

2 Select the object **par2** only.

3 In the **Settings** window for **Partition Objects**, locate the **Partition Objects** section.

4 From the **Partition with** list, choose **Work plane**.

Form Union (fin)

1 In the **Geometry** toolbar, click  **Build All**.

2 Click the  **Go to Default View** button in the **Graphics** toolbar.

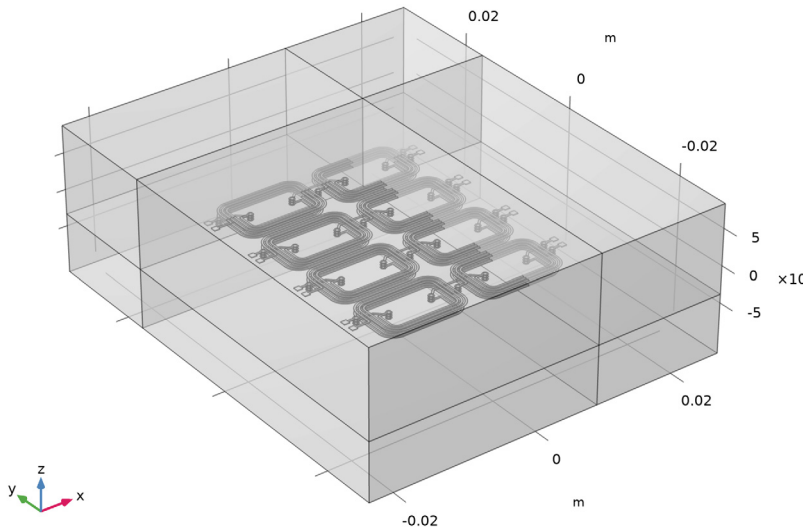

MAGNETIC FIELDS, CURRENTS ONLY (MFCO)

The geometry is now complete. Next, define coil selections for the physics interface to use. This is achieved by selecting all conductors, and then using the **Split by Connectivity** action. This generates a duplicate of the original feature for each connected component. By construction each conductor will be not adjacent to any other **Conductor**, but the selection can be further edited if necessary. If no extra editing is needed, as in the current case, the next step is to apply feeding conditions to each **Conductor**.

Conductor 1

- 1 In the **Model Builder** window, under **Component 1 (comp1)** right-click **Magnetic Fields, Currents Only (mfc0)** and choose **Conductor**.
- 2 In the **Settings** window for **Conductor**, locate the **Domain Selection** section.
- 3 From the **Selection** list, choose **Import 1**.

Conductor 12

Right-click **Conductor 1** and choose **Split by Connectivity**.

Ground 1

In the **Physics** toolbar, click  **Attributes** and choose **Ground**.

Terminal 1

Select Boundary 17 only.

Ground 1

1 In the **Model Builder** window, click **Ground 1**.

2 Select Boundary 22 only.

Conductor 2

In the **Model Builder** window, under **Component 1 (comp1)>Magnetic Fields, Currents Only (mfco)** click **Conductor 2**.

Ground 1

In the **Physics** toolbar, click  **Attributes** and choose **Ground**.

Terminal 1

1 In the **Model Builder** window, click **Terminal 1**.

2 Select Boundary 27 only.

Ground 1

1 In the **Model Builder** window, click **Ground 1**.

2 Select Boundary 32 only.

Conductor 3

In the **Model Builder** window, under **Component 1 (comp1)>Magnetic Fields, Currents Only (mfco)** click **Conductor 3**.

Ground 1

In the **Physics** toolbar, click  **Attributes** and choose **Ground**.

Terminal 1

1 In the **Model Builder** window, click **Terminal 1**.

2 Select Boundary 37 only.

Ground 1

1 In the **Model Builder** window, click **Ground 1**.

2 Select Boundary 42 only.

Conductor 4

In the **Model Builder** window, under **Component 1 (comp1)>Magnetic Fields, Currents Only (mfco)** click **Conductor 4**.

Ground 1

In the **Physics** toolbar, click  **Attributes** and choose **Ground**.

Terminal 1

- 1 In the **Model Builder** window, click **Terminal 1**.
- 2 Select Boundary 47 only.

Ground 1

- 1 In the **Model Builder** window, click **Ground 1**.
- 2 Select Boundary 52 only.

Terminal 1

- 1 In the **Model Builder** window, expand the **Component 1 (comp1)>Magnetic Fields, Currents Only (mfco)>Conductor 5** node, then click **Terminal 1**.
- 2 Select Boundary 1347 only.

Terminal 1

- 1 In the **Model Builder** window, expand the **Component 1 (comp1)>Magnetic Fields, Currents Only (mfco)>Conductor 6** node, then click **Terminal 1**.
- 2 Select Boundary 1352 only.

Terminal 1

- 1 In the **Model Builder** window, expand the **Component 1 (comp1)>Magnetic Fields, Currents Only (mfco)>Conductor 7** node, then click **Terminal 1**.
- 2 Select Boundary 1357 only.

Terminal 1

- 1 In the **Model Builder** window, expand the **Component 1 (comp1)>Magnetic Fields, Currents Only (mfco)>Conductor 8** node, then click **Terminal 1**.
- 2 Select Boundary 1362 only.

Conductor 9

In the **Model Builder** window, under **Component 1 (comp1)>Magnetic Fields, Currents Only (mfco)** click **Conductor 9**.

Ground 1

In the **Physics** toolbar, click  **Attributes** and choose **Ground**.

Terminal 1

- 1 In the **Model Builder** window, click **Terminal 1**.
- 2 Select Boundary 2913 only.

Ground 1

- 1 In the **Model Builder** window, click **Ground 1**.
- 2 Select Boundary 2914 only.

Conductor 10

In the **Model Builder** window, under **Component 1 (comp1)>Magnetic Fields, Currents Only (mfco)** click **Conductor 10**.

Ground 1

In the **Physics** toolbar, click  **Attributes** and choose **Ground**.

Terminal 1

- 1 In the **Model Builder** window, click **Terminal 1**.
- 2 Select Boundary 2915 only.

Ground 1

- 1 In the **Model Builder** window, click **Ground 1**.
- 2 Select Boundary 2916 only.

Conductor 11

In the **Model Builder** window, under **Component 1 (comp1)>Magnetic Fields, Currents Only (mfco)** click **Conductor 11**.

Ground 1

In the **Physics** toolbar, click  **Attributes** and choose **Ground**.

Terminal 1

- 1 In the **Model Builder** window, click **Terminal 1**.
- 2 Select Boundary 2917 only.

Ground 1

- 1 In the **Model Builder** window, click **Ground 1**.
- 2 Select Boundary 2918 only.

Conductor 12

In the **Model Builder** window, under **Component 1 (comp1)>Magnetic Fields, Currents Only (mfco)** click **Conductor 12**.

Ground 1

In the **Physics** toolbar, click  **Attributes** and choose **Ground**.

Terminal 1

- 1 In the **Model Builder** window, click **Terminal 1**.
- 2 Select Boundary 2919 only.

Ground 1



- 1 In the **Model Builder** window, click **Ground 1**.
- 2 Select Boundary 2920 only.

DEFINITIONS

Hide for Physics 1

- 1 In the **Model Builder** window, expand the **Component 1 (comp1)>Definitions** node.
- 2 Right-click **View 1** and choose **Hide for Physics**.
- 3 In the **Settings** window for **Hide for Physics**, locate the **Geometric Entity Selection** section.
- 4 From the **Geometric entity level** list, choose **Boundary**.
- 5 Select Boundaries 4, 5, and 7 only.

MESH 1

- 1 In the **Model Builder** window, under **Component 1 (comp1)** click **Mesh 1**.
- 2 In the **Settings** window for **Mesh**, locate the **Physics-Controlled Mesh** section.
- 3 From the **Element size** list, choose **Fine**.
- 4 Click the  **Go to Default View** button in the **Graphics** toolbar.
- 5 Click the  **Transparency** button in the **Graphics** toolbar.

6 Click  **Build All**.

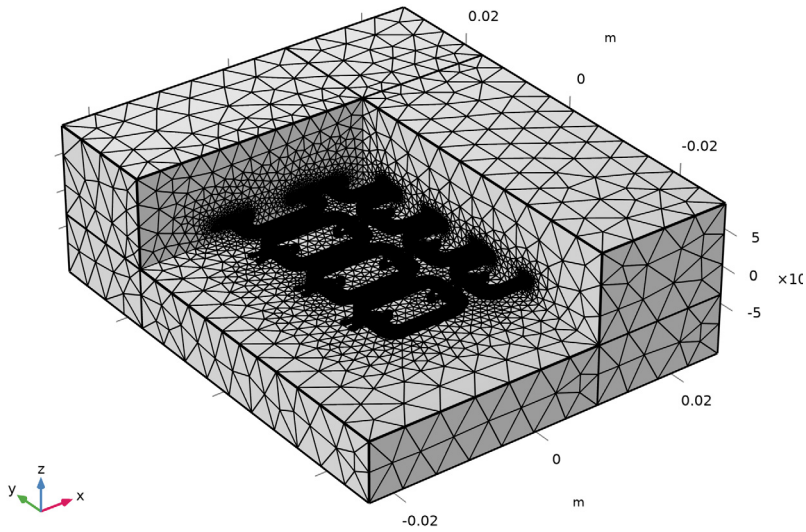

MATERIALS

Material 1 (mat1)

- 1 In the **Model Builder** window, under **Component 1 (comp1)** right-click **Materials** and choose **Blank Material**.
- 2 In the **Settings** window for **Material**, locate the **Geometric Entity Selection** section.
- 3 From the **Selection** list, choose **Import 1**.
- 4 Locate the **Material Contents** section. In the table, enter the following settings:

Property	Variable	Value	Unit	Property group
Electrical conductivity	sigma_iso ; sigma_ii = sigma_iso, sigma_ij = 0	6e7	S/m	Basic

STUDY 1

In the **Home** toolbar, click  **Compute**.

RESULTS

Multislice 1

Now use the blocks around the coil geometry to create an illustration of the magnetic flux density norm. Remember to choose to solution where the coil that intersects the chosen planes is active.

- 1 In the **Model Builder** window, expand the **Magnetic Flux Density Norm (mfco)** node, then click **Multislice 1**.
- 2 In the **Settings** window for **Multislice**, locate the **Multiplane Data** section.
- 3 Find the **x-planes** subsection. In the **Coordinates** text field, type 7[mm].
- 4 Find the **y-planes** subsection. In the **Coordinates** text field, type 14.25[mm].
- 5 Find the **z-planes** subsection. In the **Coordinates** text field, type -2[mm].
- 6 Click to expand the **Range** section. Select the **Manual color range** check box.
- 7 In the **Maximum** text field, type 8.0E-4.

Streamline Multislice 1

- 1 In the **Model Builder** window, click **Streamline Multislice 1**.
- 2 In the **Settings** window for **Streamline Multislice**, locate the **Multiplane Data** section.
- 3 Find the **x-planes** subsection. In the **Coordinates** text field, type 7[mm].
- 4 Find the **y-planes** subsection. In the **Coordinates** text field, type 14.25[mm].
- 5 Find the **z-planes** subsection. In the **Coordinates** text field, type -2[mm].

Magnetic Flux Density Norm (mfco)

Right-click **Results>Magnetic Flux Density Norm (mfco)>Streamline Multislice 1** and choose **Surface**.

Surface 1

- 1 In the **Settings** window for **Surface**, locate the **Expression** section.
- 2 In the **Expression** text field, type 1.

Selection 1

- 1 Right-click **Surface 1** and choose **Selection**.
- 2 In the **Settings** window for **Selection**, locate the **Selection** section.
- 3 From the **Selection** list, choose **Import 1**.

Material Appearance 1

- 1 Right-click **Surface 1** and choose **Material Appearance**.

- 2 In the **Settings** window for **Material Appearance**, locate the **Appearance** section.
- 3 From the **Appearance** list, choose **Custom**.
- 4 From the **Material type** list, choose **Copper**.

Magnetic Flux Density Norm (DC)

- 1 In the **Model Builder** window, under **Results** click **Magnetic Flux Density Norm (mfco)**.
- 2 In the **Settings** window for **3D Plot Group**, type Magnetic Flux Density Norm (DC) in the **Label** text field.
- 3 Locate the **Data** section. From the **Parameter value (PortName)** list, choose **8**.
- 4 Click to expand the **Title** section. From the **Title type** list, choose **Label**.
- 5 Locate the **Plot Settings** section. Clear the **Plot dataset edges** check box.
- 6 Locate the **Color Legend** section. Clear the **Show maximum and minimum values** check box.
- 7 In the **Magnetic Flux Density Norm (DC)** toolbar, click  **Plot**.

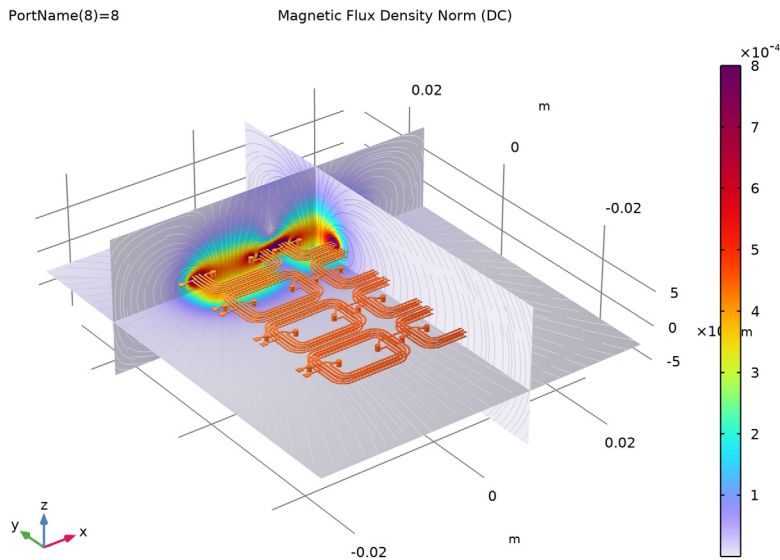

Resistance (DC) (dset1, mfco)

- 1 In the **Model Builder** window, expand the **Results>Lumped Parameters (dset1, mfco)** node, then click **Resistance (DC) (dset1, mfco)**.
- 2 In the **Resistance (DC) (dset1, mfco)** toolbar, click  **Evaluate**.

Inductance (DC) (dset1, mfco)

- 1 In the **Model Builder** window, click **Inductance (DC) (dset1, mfco)**.
- 2 In the **Inductance (DC) (dset1, mfco)** toolbar, click  **Evaluate**.

The inductance matrix is shown in the table, and can be plotted as well.

TABLE

- 1 Go to the **Table** window.
- 2 Click **Table Surface** in the window toolbar.

RESULTS

Table Surface 1

- 1 In the **Model Builder** window, under **Results>2D Plot Group 2** click **Table Surface 1**.
- 2 In the **Settings** window for **Table Surface**, locate the **Data** section.
- 3 From the **Data format** list, choose **Cells**.
- 4 Locate the **Coloring and Style** section. From the **Function** list, choose **Discrete**.
- 5 In the **2D Plot Group 2** toolbar, click  **Plot**.
- 6 From the **Color table** list, choose **Wave**.
- 7 From the **Scale** list, choose **Linear symmetric**.
- 8 Click to expand the **Title** section. From the **Title type** list, choose **None**.

Inductance Matrix (DC)

- 1 In the **Model Builder** window, under **Results** click **2D Plot Group 2**.
- 2 In the **Settings** window for **2D Plot Group**, type Inductance Matrix (DC) in the **Label** text field.

3 In the **Inductance Matrix (DC)** toolbar, click  **Plot**.

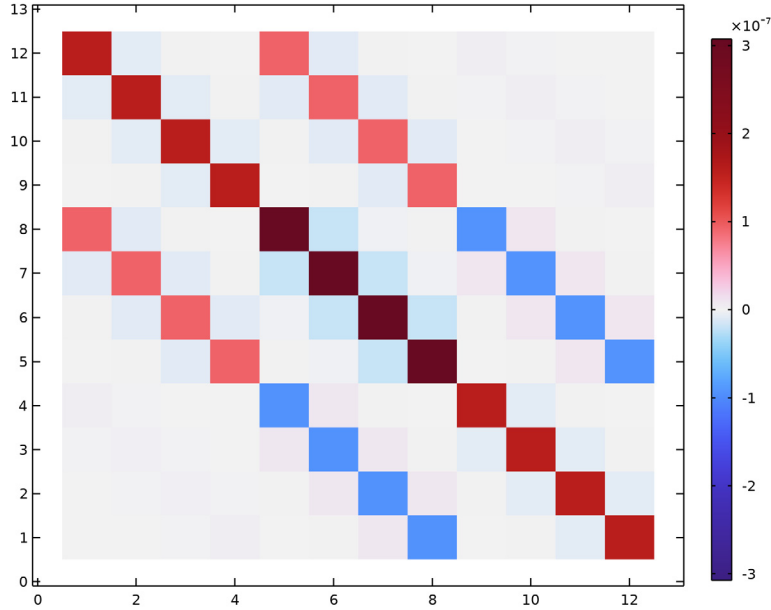

Terminal Number

The splitting of the different conductors can now be illustrated by plotting the terminal numbers.

- 1 In the **Home** toolbar, click  **Add Plot Group** and choose **3D Plot Group**.
- 2 In the **Settings** window for **3D Plot Group**, type Terminal Number in the **Label** text field.



Volume 1

- 1 Right-click **Terminal Number** and choose **Volume**.
- 2 In the **Settings** window for **Volume**, click **Replace Expression** in the upper-right corner of the **Expression** section. From the menu, choose **Component 1 (comp1)>Magnetic Fields, Currents Only>Conductors>mfc.TerminalNumber - Terminal number**.
- 3 Locate the **Coloring and Style** section. From the **Color table** list, choose **Cyclic**.

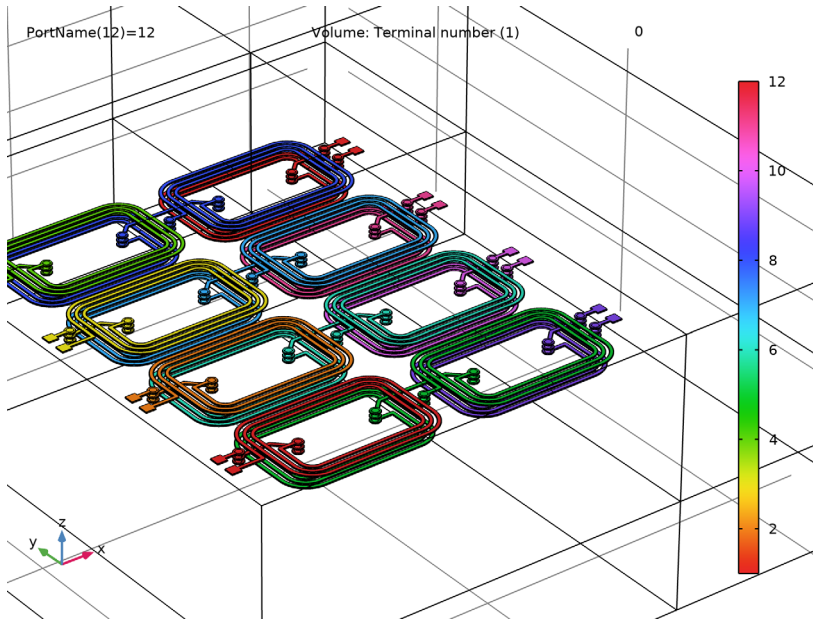
4 In the **Terminal Number** toolbar, click  **Plot**.



ADD STUDY

- 1 In the **Home** toolbar, click  **Add Study** to open the **Add Study** window.
- 2 Go to the **Add Study** window.
- 3 Find the **Studies** subsection. In the **Select Study** tree, select **Preset Studies for Selected Physics Interfaces > Frequency Domain Source Sweep with Initialization**.
- 4 Click **Add Study** in the window toolbar.
- 5 In the **Home** toolbar, click  **Add Study** to close the **Add Study** window.

STUDY 2

Step 2: Frequency Domain Source Sweep

- 1 In the **Model Builder** window, under **Study 2** click **Step 2: Frequency Domain Source Sweep**.
- 2 In the **Settings** window for **Frequency Domain Source Sweep**, locate the **Study Settings** section.
- 3 In the **Frequencies** text field, type 200[kHz].
- 4 In the **Home** toolbar, click  **Compute**.

RESULTS

Magnetic Flux Density Norm (mfco)

Right-click **Results>Magnetic Flux Density Norm (mfco)** and choose **Delete**.

Magnetic Flux Density Norm (AC)

- 1 In the **Model Builder** window, right-click **Magnetic Flux Density Norm (DC)** and choose **Duplicate**.
- 2 In the **Settings** window for **3D Plot Group**, type **Magnetic Flux Density Norm (AC)** in the **Label** text field.
- 3 Locate the **Data** section. From the **Dataset** list, choose **Study 2/Solution 3 (sol3)**.
- 4 From the **Parameter value (PortName)** list, choose **8**.
- 5 In the **Magnetic Flux Density Norm (AC)** toolbar, click  **Plot**.

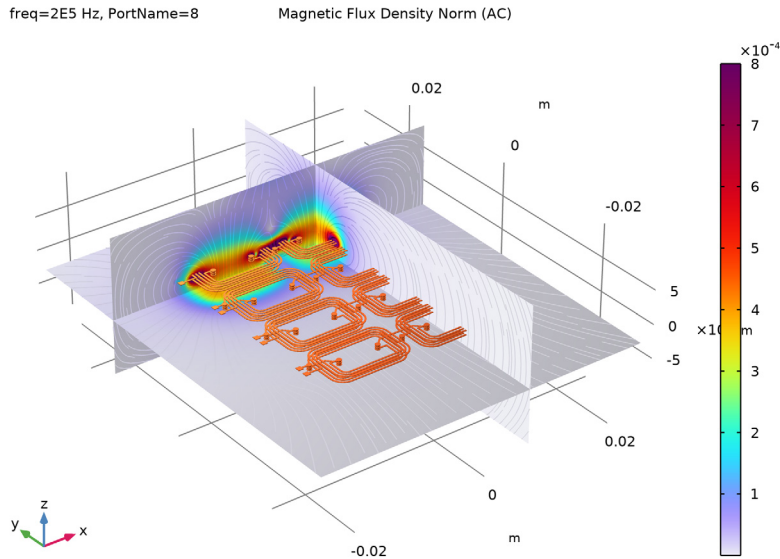

Resistance (DC) (dset3, mfco)

- 1 In the **Model Builder** window, expand the **Results>Lumped Parameters (dset3, mfco)** node, then click **Resistance (DC) (dset3, mfco)**.
- 2 In the **Resistance (DC) (dset3, mfco)** toolbar, click  **Evaluate**.

Resistance (AC) (dset3, mfco)

- 1 In the **Model Builder** window, click **Resistance (AC) (dset3, mfco)**.

2 In the **Resistance (AC) (dset3, mfco)** toolbar, click  **Evaluate**.

Inductance (AC) (dset3, mfco)

1 In the **Model Builder** window, expand the **Inductance (AC) (dset3, mfco)** node, then click **Inductance (AC) (dset3, mfco)**.

2 In the **Settings** window for **Global Matrix Evaluation**, locate the **Data Series Operation** section.

3 From the **Parameter (freq)** list, choose **Sum**.

4 In the **Inductance (AC) (dset3, mfco)** toolbar, click  **Evaluate**.

Impedance (dset3, mfco)

1 In the **Model Builder** window, under **Results>Lumped Parameters (dset3, mfco)** click **Impedance (dset3, mfco)**.

2 In the **Impedance (dset3, mfco)** toolbar, click  **Evaluate**.

Inductance Matrix (AC)

1 In the **Model Builder** window, right-click **Inductance Matrix (DC)** and choose **Duplicate**.

2 In the **Settings** window for **2D Plot Group**, type **Inductance Matrix (AC)** in the **Label** text field.

Table Surface 1

1 In the **Model Builder** window, expand the **Inductance Matrix (AC)** node, then click **Table Surface 1**.

2 In the **Settings** window for **Table Surface**, locate the **Data** section.

3 From the **Evaluation group** list, choose **Inductance (AC) (dset3, mfco)**.

4 From the **Data format** list, choose **Cells**.

5 In the **Inductance Matrix (AC)** toolbar, click  **Plot**.

