

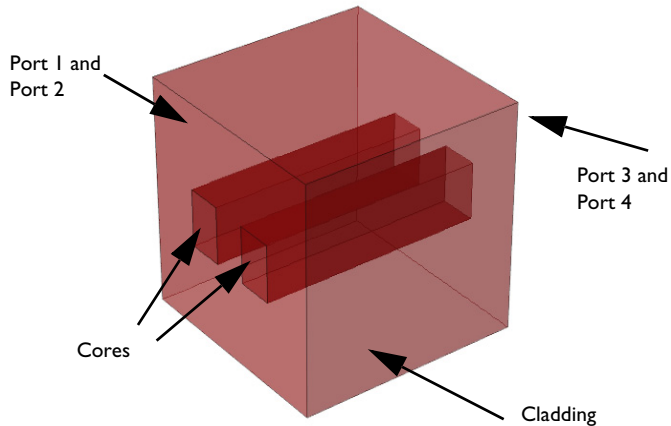


# Directional Coupler

## Introduction

---

Directional couplers are used for coupling a light wave from one waveguide to another waveguide. By controlling the refractive index in the two waveguides, for instance by heating or current injection, it is possible to control the amount of coupling between the waveguides.



*Figure 1: Schematic drawing of the waveguide structure. The structure consists of the two waveguide cores and the surrounding cladding. Port 1 and 2 are used for exciting the waveguides and Port 3 and 4 absorb the waves.*

Light that propagates through a dielectric waveguide has most of the power concentrated within the central core of the waveguide. Outside the waveguide core, in the cladding, the electric field decays exponentially with the distance from the core. However, if you put another waveguide core close to the first waveguide (see [Figure 1](#)), that second waveguide perturbs the mode of the first waveguide (and vice versa). Thus, instead of having two modes with the same effective index, one localized in the first waveguide and the second mode in the second waveguide, the modes and their respective effective indices split and you get a symmetric supermode (see [Figure 2](#) and [Figure 4](#) below), with an effective index that is slightly larger than the effective index of the unperturbed waveguide mode, and an antisymmetric supermode (see [Figure 3](#) and [Figure 5](#)), with an effective index that is slightly lower than the effective index of the unperturbed waveguide mode.

Since the supermodes are the solution to the wave equation, if you excite one of them, it propagates unperturbed through the waveguide. However, if you excite both the symmetric and the antisymmetric mode, that have different propagation constants, there is a beating between these two waves. Thus, you see that the power fluctuates back and forth between the two waveguides, as the waves propagate through the waveguide structure. You can adjust the length of the waveguide structure to get coupling from one waveguide to the other waveguide. By adjusting the phase difference between the fields of the two supermodes, you can decide which waveguide is initially excited.

### *Model Definition*

---

The directional coupler, as shown in [Figure 1](#), consists of two waveguide cores embedded in a cladding material. The cladding material is GaAs, with ion-implanted GaAs for the waveguide cores. The structure is modeled after [Ref. 1](#).

The core cross-section is square, with a side length of  $3\ \mu\text{m}$ . The two waveguides are separated  $3\ \mu\text{m}$ . The length of the waveguide structure is  $2\ \text{mm}$ . Thus, given the tiny cross-section, compared to the length, it is advantageous to use a view that doesn't preserve the aspect ratio for the geometry.

For this kind of problem, where the propagation length is much longer than the wavelength, the Electromagnetic Waves, Beam Envelopes interface is particularly suitable, as the mesh does not need to resolve the wave on a wavelength scale, but rather the beating between the two waves.

The model is setup to factor out the fast phase variation that occurs in synchronism with the first mode. Mathematically, write the total electric field as the sum of the electric fields of the two modes:

$$\begin{aligned}\mathbf{E}(\mathbf{r}) &= \mathbf{E}_1 \exp(-j\beta_1 x) + \mathbf{E}_2 \exp(-j\beta_2 x) \\ &= [\mathbf{E}_1 + \mathbf{E}_2 \exp(-j(\beta_2 - \beta_1)x)] \exp(-j\beta_1 x)\end{aligned}$$

The expression within the square parentheses is solved for. It has a beat length  $L$  defined by

$$(\beta_2 - \beta_1)L = 2\pi$$

or

$$L = \frac{2\pi}{\beta_2 - \beta_1}$$

In the simulation, this beat length must be well resolved. Since the waveguide length is half of the beat length and the waveguide length is discretized into 20 subdivisions, the beat length is well resolved in the model.

The model uses two numeric ports per input and exit boundary (see [Figure 1](#)). The two ports define the lowest symmetric and antisymmetric modes of the waveguide structure.

In the second part of the modeling procedure, the bidirectional formulation is used. In this case, the two wave vectors are codirectional — they point in the same direction. However, the magnitude of the wave vectors are given by the propagation constants of the two beating modes. In this case, you expect the two waves to have almost constant amplitudes, so the mesh can be very coarse in the propagation direction.

A problem with the first two procedures is that the numerical procedure returns mode fields with an arbitrary phase. Thus, when you superpose the two input port modes, the result can be different on different computers. In the last part of the modeling procedure, it is shown how you can form a summation of the mode fields, with expansion coefficients that are calculated to minimize the difference between the summed mode fields and a target field. Thereby, independently of the mode fields' phases, the resulting superposition will be stable.

The summation of the two input ports' mode fields should approximate the target field, as expressed in

$$\mathbf{E}_{T,\text{target}} = \sum_{i=1}^2 c_i \mathbf{E}_{T0,i}, \quad (1)$$

where  $\mathbf{E}_{T,\text{target}}$  is the tangential target electric field and  $c_i$  and  $\mathbf{E}_{T0,i}$  are the expansion coefficients and the tangential non-normalized electric mode fields for mode  $i$ , respectively. Taking the cross product with the complex conjugate of the tangential magnetic mode field for mode  $j$ , multiplying with the port normal and integrating over the port boundary, we get

$$\int_A (\mathbf{E}_{T,\text{target}} \times \mathbf{H}_{T0,j}^*) \cdot \hat{\mathbf{n}} dS = \sum_{i=1}^2 c_i \int_A (\mathbf{E}_{T0,i} \times \mathbf{H}_{T0,j}^*) \cdot \hat{\mathbf{n}} dS = 2c_j P_j, \quad (2)$$

where  $P_j$  is the mode power for mode  $j$ . Thus, the expansion coefficients are given by the overlap integral

$$c_i = \frac{1}{2P_i} \int_A (\mathbf{E}_{T, \text{target}} \times \mathbf{H}^*_{T0,i}) \cdot \hat{\mathbf{n}} dS. \quad (3)$$

COMSOL defines the normalized mode field as

$$\mathbf{E}_{T,i} = \mathbf{E}_{T0,i} \sqrt{|P_{in,i}/P_i|} e^{i\theta_{in,i}}, \quad (4)$$

where  $P_{in,i}$  is the specified input power for mode  $i$  and  $\theta_{in,i}$  is the corresponding specified mode phase.

Comparing Equation 1, Equation 3, and Equation 4, we can deduce that

$$c_i = \sqrt{|P_{in,i}/P_i|} e^{i\theta_{in,i}} \quad (5)$$

or

$$|P_{in,i}| = |c_i|^2 |P_i| = \frac{1}{4|P_i|} \left| \int_A (\mathbf{E}_{T, \text{target}} \times \mathbf{H}^*_{T0,i}) \cdot \hat{\mathbf{n}} dS \right|^2 \quad (6)$$

and

$$\theta_{in,i} = \arg(c_i) = \arg\left(\frac{1}{P_i} \int_A (\mathbf{E}_{T, \text{target}} \times \mathbf{H}^*_{T0,i}) \cdot \hat{\mathbf{n}} dS\right). \quad (7)$$

Equation 6 and Equation 7 can now be used for specifying the input power and mode phase for the two exciting ports.

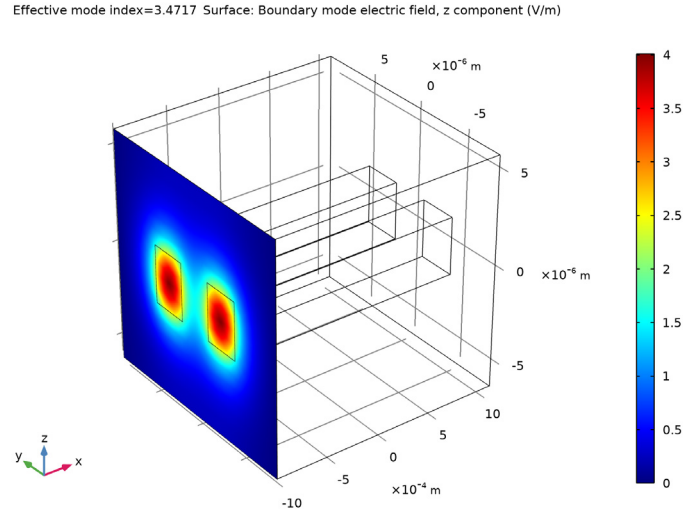
## Results and Discussion

---

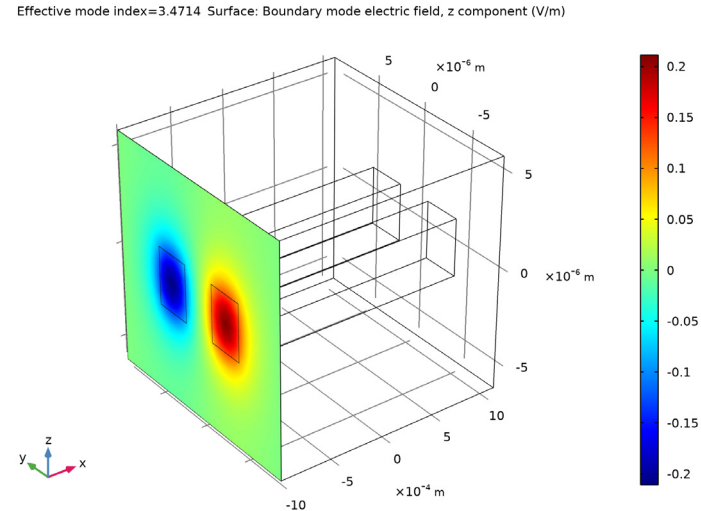
Figure 2 to Figure 5 shows the results of the initial boundary mode analysis. The first two modes (those with the largest effective mode index) are both symmetric. Figure 2 shows the first mode. This mode has the transverse polarization component along the  $z$ -direction. The second mode, shown in Figure 4, has transverse polarization along the  $y$ -direction.

Notice that your plots may look different from the plots below, as the plots show the real part of the boundary mode electric fields. The computed complex electric fields can have different phase factors than for the plots below. Thus, the color legends can have different scales and the fields can either show minima (a blue color) or maxima (a red color) at the locations for the waveguide cores. However, for a symmetric mode, it has the same field

value for both waveguide cores and for an antisymmetric mode, it has opposite field values for the two waveguide cores.



*Figure 2: The symmetric mode for z-polarization. Notice that the returned solution can also show the electric field as positive values in the peaks at the cores.*



*Figure 3: The antisymmetric mode for z-polarization.*

Figure 3 and Figure 5 show the antisymmetric modes. Those have effective indexes that are slightly smaller than those of the symmetric modes. Figure 3 shows the mode for z-polarization and Figure 5 shows the mode for y-polarization.

Effective mode index=3.4717 Surface: Boundary mode electric field, y component (V/m)

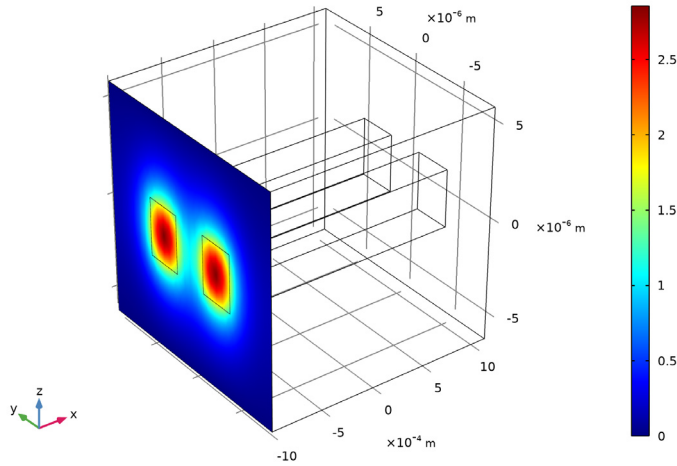


Figure 4: The symmetric mode for y-polarization. Notice that the returned solution can also show the electric field as positive values in the peaks at the cores.

Effective mode index=3.4714 Surface: Boundary mode electric field, y component (V/m)

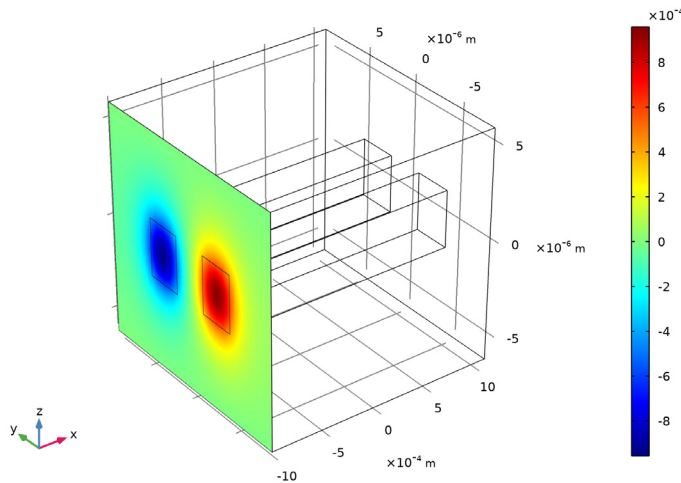


Figure 5: The antisymmetric mode for y-polarization.

Figure 6 shows how the electric field increases in the receiving waveguide and decreases in the exciting waveguide. In a longer waveguide, the waves would oscillate back and forth between the waveguides.

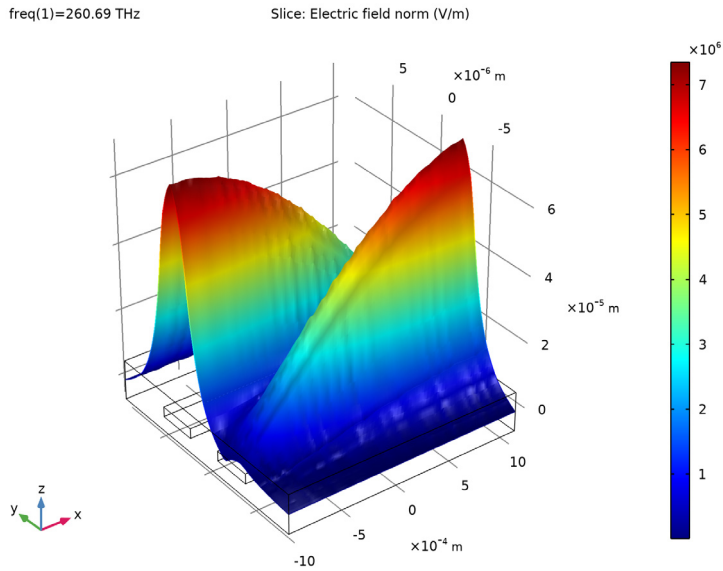
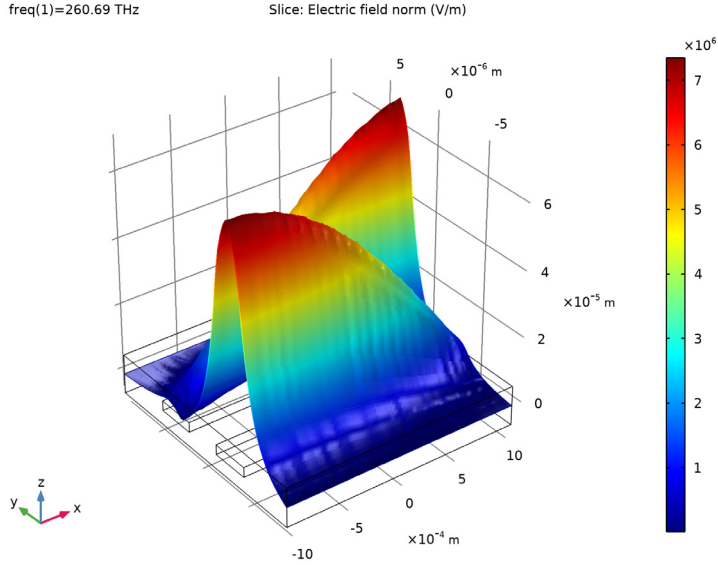


Figure 6: Excitation of the symmetric and the antisymmetric modes. The wave couples from the input waveguide to the output waveguide. Notice your result may show that the wave is excited in the other waveguide core, if your mode fields have different signs than what is displayed in Figure 2 to Figure 5.

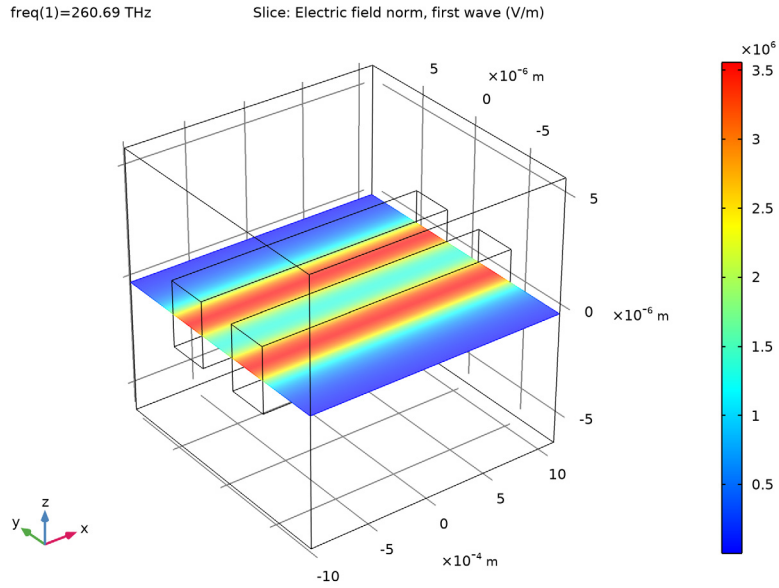
Figure 7 shows the result, when there is a  $\pi$  phase difference between the fields of the exciting ports. In this case, the superposition of the two modes results in excitation of the other waveguides (as compared to the case in Figure 6).



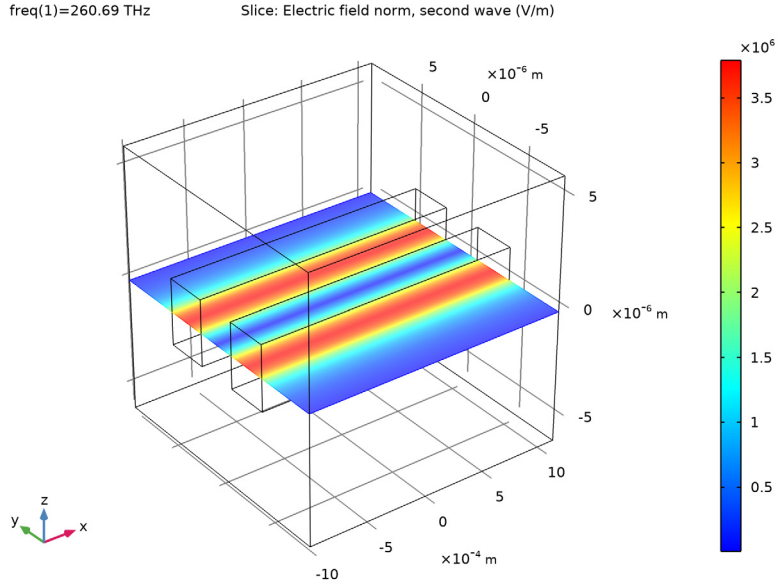


*Figure 7: The same excitation conditions as in Figure 6, except that there is a phase difference between the two ports of  $\pi$  radians. Notice your result may show that the wave is excited in the other waveguide core, if your mode fields have different signs than what is displayed in Figure 2 to Figure 5.*

Figure 8 and Figure 9 display the amplitudes of the first and second wave, respectively, when the bidirectional formulation is used. As expected, the amplitudes are almost constant.



*Figure 8: The amplitude of the first wave, when the bidirectional formulation is used.*



*Figure 9: The amplitude of the second wave, when the bidirectional formulation is used.*

Figure 10 shows that the input field approximates the square target field, centered on the left waveguide, when the input power and the mode phase for the two exciting ports are

calculated using an overlap integral between the target field and the mode field (c.f. Equation 6 and Equation 7).

freq(1)=260.69 THz Surface: Target electric field (V/m) Surface: Electric field, z component (V/m)

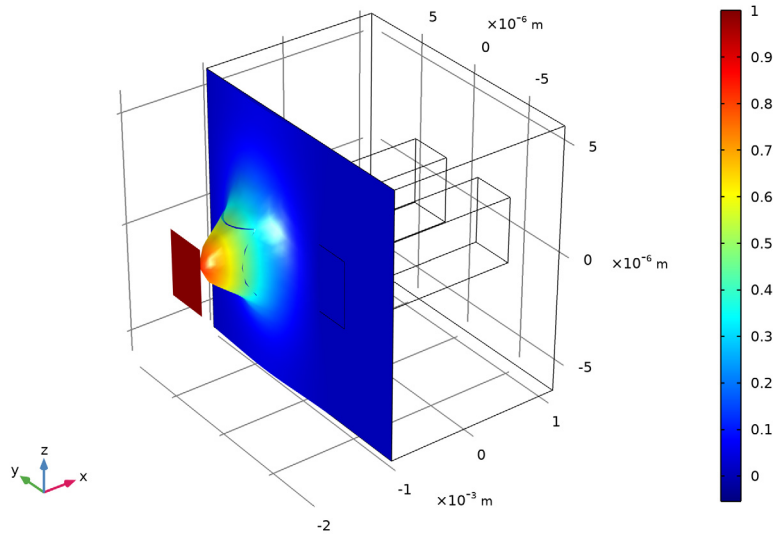


Figure 10: The red square with amplitude 1 V/m represents the target function. This target function has an amplitude of 1 V/m in the left waveguide core and 0 V/m everywhere else. The total input field is shown to be localized in the left waveguide, as expected, with an amplitude that approaches the target amplitude.

## Reference


I. S. Somekh, E. Garmire, A. Yariv, H.L. Garvin, and R.G. Hunsperger, “Channel Optical Waveguides and Directional Couplers in GaAs-Imbedded and Ridged”, *Applied Optics*, vol. 13, no. 2, pp. 327–30, 1974.

**Application Library path:** Wave\_Optics\_Module/Waveguides\_and\_Couplers/  
directional\_coupler




## Modeling Instructions

From the **File** menu, choose **New**.

## NEW

In the **New** window, click  **Model Wizard**.

## MODEL WIZARD

- 1 In the **Model Wizard** window, click  **3D**.
- 2 In the **Select Physics** tree, select **Optics>Wave Optics>Electromagnetic Waves, Beam Envelopes (ewbe)**.
- 3 Click **Add**.
- 4 Click  **Study**.
- 5 In the **Select Study** tree, select **Preset Studies for Selected Physics Interfaces>Boundary Mode Analysis**.
- 6 Click  **Done**.

## GLOBAL DEFINITIONS

First, define a set of parameters for creating the geometry and defining the material parameters.

### *Parameters 1*


- 1 In the **Model Builder** window, under **Global Definitions** click **Parameters 1**.
- 2 In the **Settings** window for **Parameters**, locate the **Parameters** section.
- 3 In the table, enter the following settings:

Name	Expression	Value	Description
lda0	1.15[um]	1.15E-6 m	Wavelength
f0	c_const/lda0	2.6069E14 1/s	Frequency
a	3[um]	3E-6 m	Side of waveguide cross-section
d	3[um]	3E-6 m	Distance between the waveguides
len	2.1[mm]	0.0021 m	Waveguide length
width	6*a	1.8E-5 m	Width of calculation domain
height	4*a	1.2E-5 m	Height of calculation domain
ncl	3.47	3.47	Refractive index of GaAs
dn	0.005	0.005	Refractive index increase in waveguide core
nco	ncl+dn	3.475	Refractive index in waveguide core

## GEOMETRY 1


Create the calculation domain.

### Block 1 (blk1)

- 1 In the **Geometry** toolbar, click  **Block**.
- 2 In the **Settings** window for **Block**, locate the **Size and Shape** section.
- 3 In the **Width** text field, type 1en.
- 4 In the **Depth** text field, type width.
- 5 In the **Height** text field, type height.
- 6 Locate the **Position** section. From the **Base** list, choose **Center**.


### Block 2 (blk2)

Now add the first embedded waveguide.

- 1 In the **Geometry** toolbar, click  **Block**.
- 2 In the **Settings** window for **Block**, locate the **Size and Shape** section.
- 3 In the **Width** text field, type 1en.
- 4 In the **Depth** text field, type a.
- 5 In the **Height** text field, type a.
- 6 Locate the **Position** section. From the **Base** list, choose **Center**.
- 7 In the **y** text field, type -d.

### Block 3 (blk3)

Add the second waveguide, by duplicating the first waveguide and modifying the position.

- 1 Right-click **Block 2 (blk2)** and choose **Duplicate**.
- 2 In the **Settings** window for **Block**, locate the **Position** section.
- 3 In the **y** text field, type d.
- 4 Click  **Build All Objects**.



## DEFINITIONS

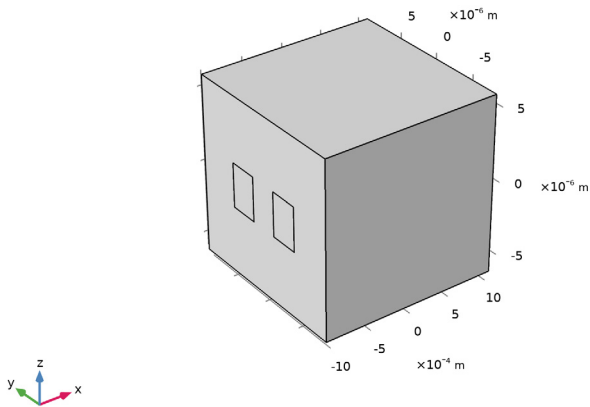
Since the geometry is so long and narrow, do not preserve the aspect ratio in the view.

- 1 In the **Model Builder** window, expand the **Component 1 (comp1)>Definitions** node.

### Camera

- 1 In the **Model Builder** window, expand the **Component 1 (comp1)>Definitions>View 1** node, then click **Camera**.

- 2 In the **Settings** window for **Camera**, locate the **Camera** section.
- 3 From the **View scale** list, choose **Automatic**.
- 4 From the **Automatic** list, choose **Anisotropic**.
- 5 Select the **Automatic update** check box.
- 6 Click  **Update**.
- 7 Click the  **Zoom Extents** button in the **Graphics** toolbar.



## MATERIALS

Now, add materials for the cladding and the core of the waveguides.

### *GaAs Cladding*

- 1 In the **Model Builder** window, under **Component 1 (comp1)** right-click **Materials** and choose **Blank Material**.
- 2 In the **Settings** window for **Material**, type **GaAs Cladding** in the **Label** text field.
- 3 Locate the **Material Contents** section. In the table, enter the following settings:

Property	Variable	Value	Unit	Property group
Refractive index, real part	$n_{\text{iso}}$ ; $n_{\text{ii}} = n_{\text{iso}}$ , $n_{\text{ij}} = 0$	$n_{\text{cl}}$	1	Refractive index

### *Implanted GaAs Core*

- 1 Right-click **Materials** and choose **Blank Material**.

- 2 In the **Settings** window for **Material**, type Implanted GaAs Core in the **Label** text field.
- 3 Select Domains 2 and 3 only.
- 4 Locate the **Material Contents** section. In the table, enter the following settings:

Property	Variable	Value	Unit	Property group
Refractive index, real part	n_iso ; nii = n_iso, nij = 0	nc0	l	Refractive index

### ELECTROMAGNETIC WAVES, BEAM ENVELOPES, UNIDIRECTIONAL

Since there will be no reflected waves in this application, it is best to select unidirectional propagation.


- 1 In the **Model Builder** window, under **Component 1 (comp1)** click **Electromagnetic Waves, Beam Envelopes (ewbe)**.
- 2 In the **Settings** window for **Electromagnetic Waves, Beam Envelopes**, type Electromagnetic Waves, Beam Envelopes, Unidirectional in the **Label** text field.
- 3 Locate the **Wave Vectors** section. From the **Number of directions** list, choose **Unidirectional**.
- 4 Specify the  **$\mathbf{k}_1$**  vector as

ewbe.beta_1	x
0	y
0	z

This sets the wave vector to be that of the lowest waveguide mode.

### Port 1

Add two numeric ports per port boundary. The first two ports excite the waveguides.

- 1 In the **Physics** toolbar, click  **Boundaries** and choose **Port**.
- 2 Select Boundaries 1, 5, and 10 only.
- 3 In the **Settings** window for **Port**, locate the **Port Properties** section.
- 4 From the **Type of port** list, choose **Numeric**.

For the first port, wave excitation is **on** by default.

Now duplicate the first port.




#### Port 2

Right-click **Port 1** and choose **Duplicate**.

#### Port 3

Next create the ports at the other end of the waveguides.

- 1 In the **Physics** toolbar, click  **Boundaries** and choose **Port**.
- 2 Select Boundaries 16–18 only.
- 3 In the **Settings** window for **Port**, locate the **Port Properties** section.
- 4 From the **Type of port** list, choose **Numeric**.

Duplicate this port.

#### Port 4

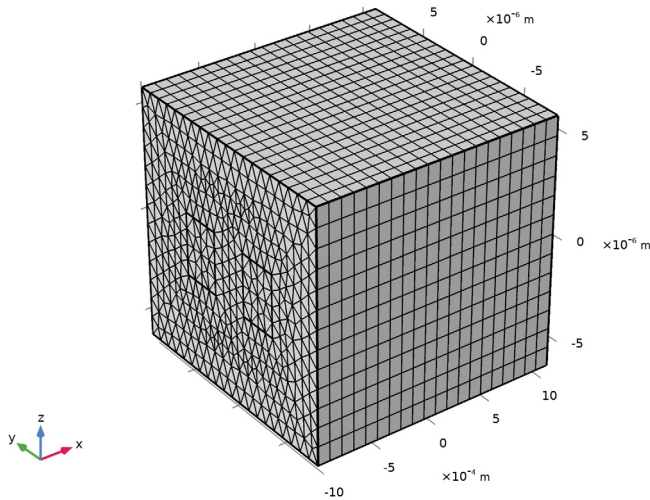
Right-click **Port 3** and choose **Duplicate**.

### **MESH, UNIDIRECTIONAL**

Now define a couple of parameters that will define the swept mesh, used in this model.

- 1 In the **Settings** window for **Mesh**, type Mesh, Unidirectional in the **Label** text field.
- 2 Locate the **Electromagnetic Waves, Beam Envelopes, Unidirectional (ewbe)** section. In the  $N_T$  text field, type 20. This will make the triangular mesh on the input boundary resolve the modes.
- 3 In the  $N_L$  text field, type 20. This will create a swept mesh with twenty elements along the waveguide. This will be sufficient to resolve the mode-coupling that will occur.

4 Click  **Build All**.



### **STUDY, UNIDIRECTIONAL**

- 1 In the **Model Builder** window, click **Study I**.
- 2 In the **Settings** window for **Study**, type Study, Unidirectional in the **Label** text field.  
Do not generate the default plots.
- 3 Locate the **Study Settings** section. Clear the **Generate default plots** check box.

#### *Step 1: Boundary Mode Analysis*

Now analyze the four lowest modes. The first two modes will be symmetric. Since the waveguide cross-section is square, there will be one mode polarized in the  $z$  direction and one mode polarized in the  $y$  direction. Mode three and four will be antisymmetric, one polarized in the  $z$  direction and the other in the  $y$  direction.


- 1 In the **Model Builder** window, under **Study, Unidirectional** click **Step 1: Boundary Mode Analysis**.
- 2 In the **Settings** window for **Boundary Mode Analysis**, locate the **Study Settings** section.
- 3 Select the **Desired number of modes** check box.
- 4 In the associated text field, type 4.  
Search for the modes with effective index close to that of the waveguide cores.
- 5 Select the **Search for modes around** check box.

- 6 In the associated text field, type `nco`.
- 7 In the **Mode analysis frequency** text field, type `f0`.  
Compute only the boundary mode analysis step.
- 8 Right-click **Study, Unidirectional>Step 1: Boundary Mode Analysis** and choose **Compute Selected Step**.

## RESULTS

Create a 3D surface plot to view the different modes.



### *Electric Field, Unidirectional*

- 1 In the **Home** toolbar, click  **Add Plot Group** and choose **3D Plot Group**.
- 2 In the **Settings** window for **3D Plot Group**, type **Electric Field, Unidirectional** in the **Label** text field.

### *Surface 1*

- 1 Right-click **Electric Field, Unidirectional** and choose **Surface**.  
First look at the modes polarized in the  $z$  direction.
- 2 In the **Settings** window for **Surface**, click **Replace Expression** in the upper-right corner of the **Expression** section. From the menu, choose **Component 1 (comp1)> Electromagnetic Waves, Beam Envelopes, Unidirectional>Boundary mode analysis> Boundary mode electric field -  $V/m$ >ewbe.tEbmIz - Boundary mode electric field, z component**.

### *Electric Field, Unidirectional*



- 1 In the **Model Builder** window, click **Electric Field, Unidirectional**.
- 2 In the **Settings** window for **3D Plot Group**, locate the **Data** section.
- 3 From the **Effective mode index** list, choose **3.4717**, which should be the largest effective index.
- 4 In the **Electric Field, Unidirectional** toolbar, click  **Plot**. This plot shows the symmetric mode polarized in the  $z$  direction. Compare with [Figure 2](#).
- 5 From the **Effective mode index** list, choose **3.4714**, which should be the third largest effective index.
- 6 In the **Electric Field, Unidirectional** toolbar, click  **Plot**. This plot shows the anti-symmetric mode polarized in the  $z$  direction. Compare with [Figure 3](#).

### *Surface 1*



- 1 In the **Model Builder** window, click **Surface 1**.

- 2 In the **Settings** window for **Surface**, locate the **Expression** section.
- 3 In the **Expression** text field, type `ewbe.tEbm1y`.

#### *Electric Field, Unidirectional*

- 1 In the **Model Builder** window, click **Electric Field, Unidirectional**.
  - 2 In the **Settings** window for **3D Plot Group**, locate the **Data** section.
  - 3 From the **Effective mode index** list, choose **3.4717**, which should be the second largest effective index.
  - 4 In the **Electric Field, Unidirectional** toolbar, click  **Plot**. This plot shows the symmetric mode polarized in the y direction. Compare with [Figure 4](#).
  - 5 From the **Effective mode index** list, choose **3.4714**, which should be the smallest effective index.
  - 6 In the **Electric Field, Unidirectional** toolbar, click  **Plot**. This plot shows the anti-symmetric mode polarized in the y direction. Compare with [Figure 5](#).
- You will need to copy the effective indexes for the different modes and use them in the boundary mode analyses for the different ports.

#### *Global Evaluation 1*

- 1 In the **Results** toolbar, click  **Global Evaluation**.
- 2 In the **Settings** window for **Global Evaluation**, click **Replace Expression** in the upper-right corner of the **Expressions** section. From the menu, choose **Component 1 (comp1)> Electromagnetic Waves, Beam Envelopes, Unidirectional>Ports>Propagation constants> ewbe.beta\_1 - Propagation constant - rad/m**.
- 3 Click  **Evaluate**.

#### **TABLE**

- 1 Go to the **Table** window.
 

Copy all information in the table to the clipboard. Then paste that information in a text editor, so you easily can enter the values later in the boundary mode analysis steps.
- 2 Click **Full Precision** in the window toolbar.
- 3 Click **Copy Table and Headers to Clipboard** in the window toolbar.

#### **STUDY, UNIDIRECTIONAL**

##### *Step 1: Boundary Mode Analysis*

- 1 In the **Model Builder** window, under **Study, Unidirectional** click **Step 1: Boundary Mode Analysis**.

- 2 In the **Settings** window for **Boundary Mode Analysis**, locate the **Study Settings** section.
- 3 In the **Desired number of modes** text field, type 1.
- 4 In the **Search for modes around** text field, type 3.4716717443092047, by selecting the value in your text editor and then copying and pasting it here. This should be the largest effective index. The last figures could be different from what is written here.

*Step 3: Boundary Mode Analysis 1*

- 1 Right-click **Study, Unidirectional>Step 1: Boundary Mode Analysis** and choose **Duplicate**.
- 2 In the **Settings** window for **Boundary Mode Analysis**, locate the **Study Settings** section.
- 3 In the **Search for modes around** text field, type 3.4714219480792172, by selecting the value in your text editor and then copying and pasting it here. This should be the third largest effective index. The last figures could be different from what is written here.
- 4 In the **Port name** text field, type 2.

*Step 1: Boundary Mode Analysis, Step 3: Boundary Mode Analysis 1*

In the **Model Builder** window, under **Study, Unidirectional**, Ctrl-click to select **Step 1: Boundary Mode Analysis** and **Step 3: Boundary Mode Analysis 1**.


*Step 4: Boundary Mode Analysis 2*

- 1 Right-click and choose **Duplicate**.
- 2 In the **Settings** window for **Boundary Mode Analysis**, locate the **Study Settings** section.
- 3 In the **Port name** text field, type 3.

*Step 5: Boundary Mode Analysis 3*

- 1 In the **Model Builder** window, click **Step 5: Boundary Mode Analysis 3**.
- 2 In the **Settings** window for **Boundary Mode Analysis**, locate the **Study Settings** section.
- 3 In the **Port name** text field, type 4.

*Step 2: Frequency Domain*

- 1 In the **Model Builder** window, click **Step 2: Frequency Domain**.
- 2 In the **Settings** window for **Frequency Domain**, locate the **Study Settings** section.
- 3 In the **Frequencies** text field, type f0.
- 4 Finally, move **Step2: Frequency Domain** to be the last study step, either by three times right-clicking it and choosing **Move Down** or by simply dragging it and dropping it at the last position in the list.
- 5 In the **Home** toolbar, click  **Compute**.

## RESULTS

### *Surface 1*

Remove the surface plot and replace it with a slice plot of the norm of the electric field.

- 1 In the **Model Builder** window, under **Results>Electric Field, Unidirectional** right-click **Surface 1** and choose **Delete**.



### *Electric Field, Unidirectional*

- 1 In the **Model Builder** window, click **Electric Field, Unidirectional**.
- 2 Click **Yes** to confirm.

### *Slice 1*

- 1 Right-click **Electric Field, Unidirectional** and choose **Slice**.
- 2 In the **Settings** window for **Slice**, locate the **Plane Data** section.
- 3 From the **Plane** list, choose **XY-planes**.
- 4 In the **Planes** text field, type 1.
- 5 Click to expand the **Quality** section. From the **Smoothing** list, choose **Everywhere**. This makes the deformation plot smooth across the core-cladding interfaces.

### *Deformation 1*

- 1 Right-click **Slice 1** and choose **Deformation**.
- 2 In the **Settings** window for **Deformation**, locate the **Expression** section.
- 3 In the **Z component** text field, type `ewbe.normE`.
- 4 In the **Electric Field, Unidirectional** toolbar, click  **Plot**.
- 5 Click the **Go to View 1** button in the **Graphics** toolbar.
- 6 Click the  **Zoom Extents** button in the **Graphics** toolbar. The plot shows how the light couples from the excited waveguide to the unexcited one; compare with [Figure 6](#).


## ELECTROMAGNETIC WAVES, BEAM ENVELOPES, UNIDIRECTIONAL (EWBE)

### *Port 2*

To excite the other waveguide, set the phase difference between the exciting ports to  $\pi$ .


- 1 In the **Model Builder** window, under **Component 1 (comp1)>Electromagnetic Waves, Beam Envelopes, Unidirectional (ewbe)** click **Port 2**.
- 2 In the **Settings** window for **Port**, locate the **Port Mode Settings** section.
- 3 In the  $\theta_{in}$  text field, type `pi`.

## STUDY, UNIDIRECTIONAL

In the **Home** toolbar, click  **Compute**.

## RESULTS

*Electric Field, Unidirectional*

1 Click the  **Zoom Extents** button in the **Graphics** toolbar.

Now the other waveguide is excited and the coupling occurs in reverse direction, compared to the previous case. Compare your result with that in [Figure 7](#).

## ELECTROMAGNETIC WAVES, BEAM ENVELOPES, UNIDIRECTIONAL (EWBE)

The following instructions demonstrate how to make a bidirectional simulation, where the two wave vectors are codirectional but use the propagation constants of the two beating modes.

1 In the **Model Builder** window, under **Component 1 (comp1)** right-click **Electromagnetic Waves, Beam Envelopes, Unidirectional (ewbe)** and choose **Copy**.

## ELECTROMAGNETIC WAVES, BEAM ENVELOPES, BIDIRECTIONAL

1 In the **Model Builder** window, right-click **Component 1 (comp1)** and choose **Paste Electromagnetic Waves, Beam Envelopes**.

2 In the **Messages from Paste** dialog box, click **OK**.

3 In the **Settings** window for **Electromagnetic Waves, Beam Envelopes**, type **Electromagnetic Waves, Beam Envelopes, Bidirectional** in the **Label** text field.

4 Locate the **Wave Vectors** section. From the **Number of directions** list, choose **Bidirectional**.


5 Specify the  $\mathbf{k}_2$  vector as


ewbe.beta_2	x
ewbe.k1y	y
ewbe.k1z	z

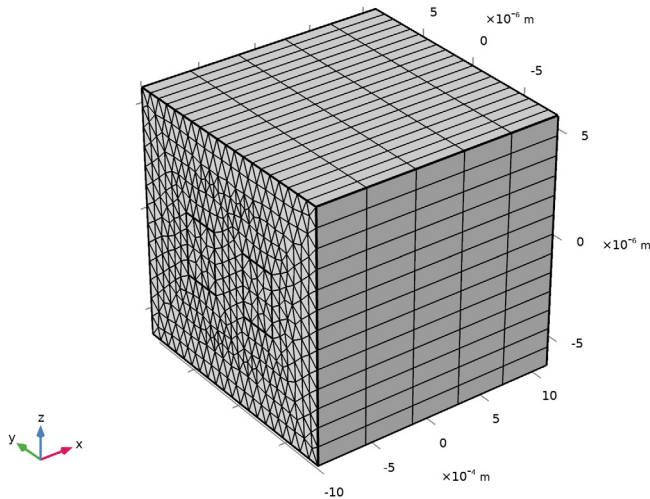
## COMPONENT 1 (COMP1)

In this case, each wave will have an almost constant amplitude, so a very coarse mesh can be used in the propagation direction.


## MESH, BIDIRECTIONAL

1 In the **Mesh** toolbar, click  **Add Mesh**.


- 2 In the **Settings** window for **Mesh**, type Mesh, Bidirectional in the **Label** text field.
- 3 Locate the **Physics-Controlled Mesh** section. In the table, clear the **Use** check box for **Electromagnetic Waves, Beam Envelopes, Unidirectional (ewbe)**.
- 4 Locate the **Electromagnetic Waves, Beam Envelopes, Bidirectional (ewbe2)** section. In the  $N_L$  text field, type 5.  
Inspect the coarser mesh.
- 5 Click  **Build All**.



### ADD STUDY

- 1 In the **Home** toolbar, click  **Add Study** to open the **Add Study** window.
- 2 Go to the **Add Study** window.
- 3 Find the **Studies** subsection. In the **Select Study** tree, select **Empty Study**.
- 4 Click **Add Study** in the window toolbar.

### STUDY, BIDIRECTIONAL

- 1 In the **Settings** window for **Study**, type Study, Bidirectional in the **Label** text field.
- 2 Locate the **Study Settings** section. Clear the **Generate default plots** check box.
- 3 In the **Home** toolbar, click  **Add Study** to close the **Add Study** window.



## STUDY, UNIDIRECTIONAL

*Step 1: Boundary Mode Analysis, Step 2: Boundary Mode Analysis 1, Step 3: Boundary Mode Analysis 2, Step 4: Boundary Mode Analysis 3, Step 5: Frequency Domain*

- 1 In the **Model Builder** window, under **Study, Unidirectional**, Ctrl-click to select **Step 1: Boundary Mode Analysis, Step 2: Boundary Mode Analysis 1, Step 3: Boundary Mode Analysis 2, Step 4: Boundary Mode Analysis 3, and Step 5: Frequency Domain.**
- 2 Right-click and choose **Copy**.

## STUDY, BIDIRECTIONAL

*Step 1: Boundary Mode Analysis*

- 1 In the **Model Builder** window, right-click **Study, Bidirectional** and choose **Paste Multiple Items**.
- 2 In the **Settings** window for **Boundary Mode Analysis**, locate the **Physics and Variables Selection** section.
- 3 In the table, clear the **Solve for** check box for **Electromagnetic Waves, Beam Envelopes, Unidirectional (ewbe)**.
- 4 Click to expand the **Mesh Selection** section. In the table, enter the following settings:

Geometry	Mesh
Geometry 1	Mesh, Bidirectional

*Step 2: Boundary Mode Analysis 1*

- 1 In the **Model Builder** window, click **Step 2: Boundary Mode Analysis 1**.
- 2 In the **Settings** window for **Boundary Mode Analysis**, locate the **Physics and Variables Selection** section.
- 3 In the table, clear the **Solve for** check box for **Electromagnetic Waves, Beam Envelopes, Unidirectional (ewbe)**.
- 4 Click to expand the **Mesh Selection** section. In the table, enter the following settings:

Geometry	Mesh
Geometry 1	Mesh, Bidirectional

*Step 3: Boundary Mode Analysis 2*

- 1 In the **Model Builder** window, click **Step 3: Boundary Mode Analysis 2**.

- 2 In the **Settings** window for **Boundary Mode Analysis**, locate the **Physics and Variables Selection** section.
- 3 In the table, clear the **Solve for** check box for **Electromagnetic Waves, Beam Envelopes, Unidirectional (ewbe)**.
- 4 Click to expand the **Mesh Selection** section. In the table, enter the following settings:

Geometry	Mesh
Geometry 1	Mesh, Bidirectional

*Step 4: Boundary Mode Analysis 3*

- 1 In the **Model Builder** window, click **Step 4: Boundary Mode Analysis 3**.
- 2 In the **Settings** window for **Boundary Mode Analysis**, locate the **Physics and Variables Selection** section.
- 3 In the table, clear the **Solve for** check box for **Electromagnetic Waves, Beam Envelopes, Unidirectional (ewbe)**.
- 4 Click to expand the **Mesh Selection** section. In the table, enter the following settings:

Geometry	Mesh
Geometry 1	Mesh, Bidirectional

*Step 5: Frequency Domain*

- 1 In the **Model Builder** window, click **Step 5: Frequency Domain**.
- 2 In the **Settings** window for **Frequency Domain**, locate the **Physics and Variables Selection** section.
- 3 In the table, clear the **Solve for** check box for **Electromagnetic Waves, Beam Envelopes, Unidirectional (ewbe)**.
- 4 Click to expand the **Mesh Selection** section. In the table, enter the following settings:

Geometry	Mesh
Geometry 1	Mesh, Bidirectional

- 5 In the **Home** toolbar, click  **Compute**.

## RESULTS

*Electric Field, Bidirectional*


- 1 In the **Model Builder** window, right-click **Electric Field, Unidirectional** and choose **Duplicate**.

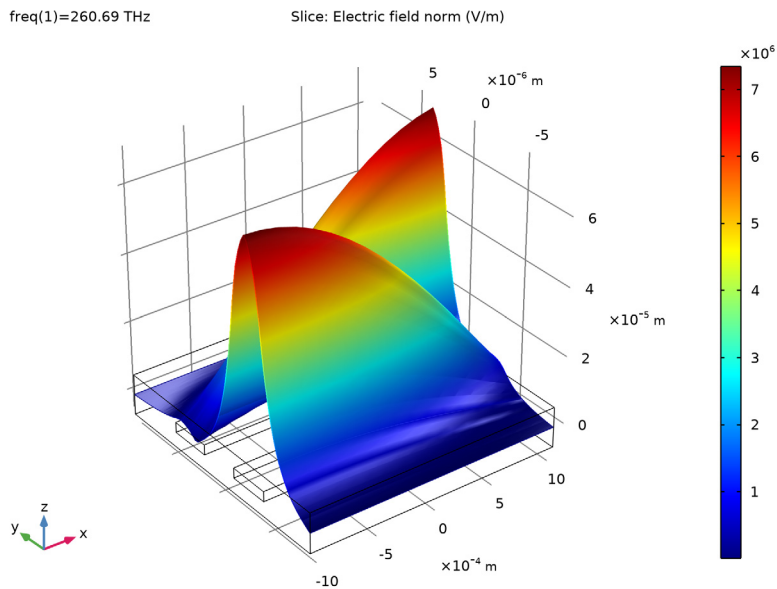
- 2 In the **Settings** window for **3D Plot Group**, type **Electric Field, Bidirectional** in the **Label** text field.
- 3 Locate the **Data** section. From the **Dataset** list, choose **Study, Bidirectional/ Solution 6 (sol6)**.

*Slice 1*

- 1 In the **Model Builder** window, expand the **Electric Field, Bidirectional** node, then click **Slice 1**.
- 2 In the **Settings** window for **Slice**, locate the **Expression** section.
- 3 In the **Expression** text field, type `ewbe2.normE`.

*Deformation 1*


- 1 In the **Model Builder** window, expand the **Slice 1** node, then click **Deformation 1**.
- 2 In the **Settings** window for **Deformation**, locate the **Expression** section.
- 3 In the **Z component** text field, type `ewbe2.normE`.
- 4 In the **Electric Field, Bidirectional** toolbar, click  **Plot**.




The resulting plot should look similar to [Figure 7](#).

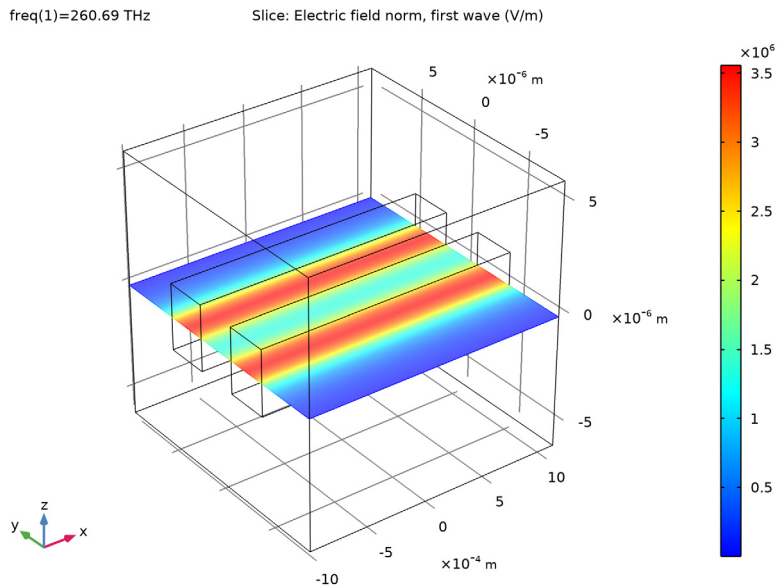
*Electric Field Amplitude, Bidirectional*

Additionally, add a plot to verify that the field amplitudes indeed are constant.

- 1 In the **Home** toolbar, click  **Add Plot Group** and choose **3D Plot Group**.
- 2 In the **Settings** window for **3D Plot Group**, type Electric Field Amplitude, Bidirectional in the **Label** text field.
- 3 Locate the **Data** section. From the **Dataset** list, choose **Study, Bidirectional/Solution 6 (sol6)**.

*Slice 1*

- 1 Right-click **Electric Field Amplitude, Bidirectional** and choose **Slice**.
- 2 In the **Settings** window for **Slice**, locate the **Expression** section.
- 3 In the **Expression** text field, type `ewbe2.normE1`.
- 4 Locate the **Plane Data** section. From the **Plane** list, choose **XY-planes**.
- 5 In the **Planes** text field, type 1.
- 6 Locate the **Coloring and Style** section. From the **Color table** list, choose **RainbowLight**.
- 7 In the **Electric Field Amplitude, Bidirectional** toolbar, click  **Plot**.

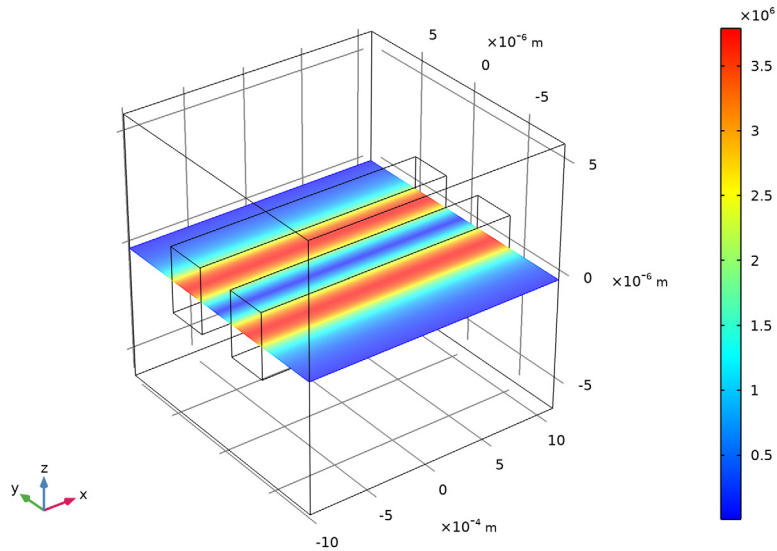


- 8 Locate the **Expression** section. In the **Expression** text field, type `ewbe2.normE2`.

9 In the **Electric Field Amplitude, Bidirectional** toolbar, click  **Plot**.

freq(1)=260.69 THz

Slice: Electric field norm, second wave (V/m)



### COMPONENT I (COMP I)

The following instructions demonstrate how to define the excited modes' power and mode phase parameters to approximate a target input field.

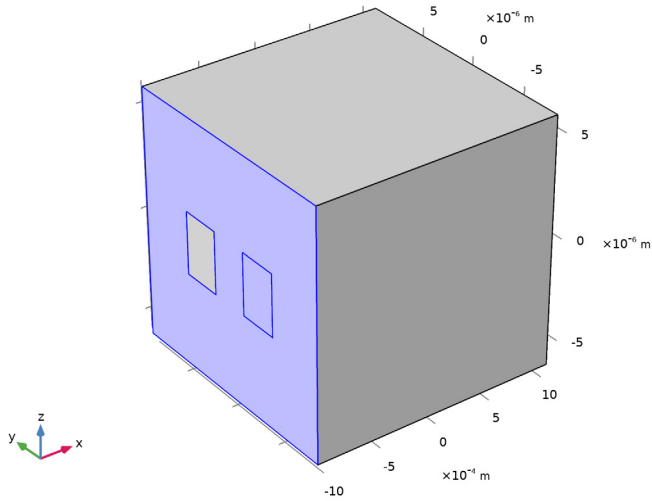
In the **Model Builder** window, expand the **Component I (comp I)** node.

### DEFINITIONS

#### *Variables 1*

- 1 In the **Model Builder** window, expand the **Component I (comp I)**>**Definitions** node.
- 2 Right-click **Definitions** and choose **Variables**, to define the target field in the cladding and in the right waveguide core.
- 3 In the **Settings** window for **Variables**, locate the **Geometric Entity Selection** section.
- 4 From the **Geometric entity level** list, choose **Boundary**.

5 Select Boundaries 1 and 5 only.




6 Locate the **Variables** section. In the table, enter the following settings:

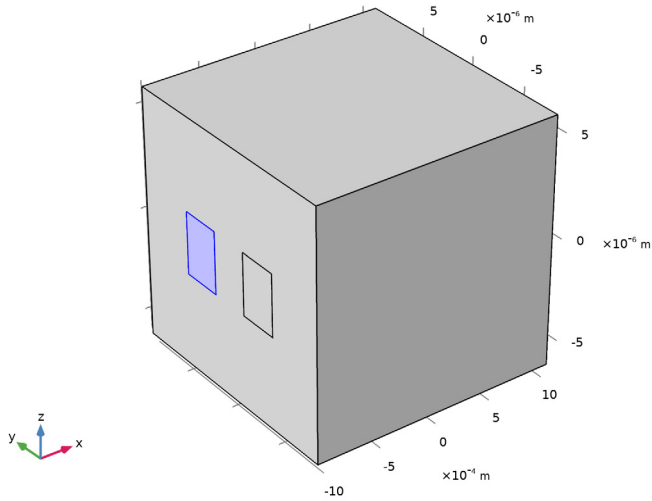
Name	Expression	Unit	Description
Etarget	0[V/m]	V/m	Target electric field

Now, define the target field in the left waveguide core.

*Variables 2*

- 1 Right-click **Variables 1** and choose **Duplicate**.
- 2 In the **Settings** window for **Variables**, locate the **Geometric Entity Selection** section.
- 3 Click  **Clear Selection**.


4 Select Boundary 10 only.



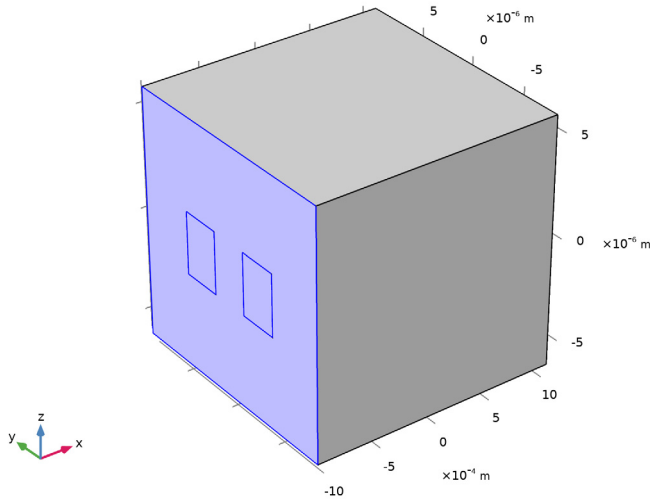
5 Locate the **Variables** section. In the table, enter the following settings:

Name	Expression	Unit	Description
Etarget	1[V/m]	V/m	Target electric field

*Integration 1 (intop1)*

- 1 In the **Definitions** toolbar, click  **Nonlocal Couplings** and choose **Integration**, to define the integration operator that will be used for computing overlap integrals between the target field and the mode fields.
- 2 In the **Settings** window for **Integration**, locate the **Source Selection** section.
- 3 From the **Geometric entity level** list, choose **Boundary**.

4 Select Boundaries 1, 5, and 10 only.



### **ELECTROMAGNETIC WAVES, BEAM ENVELOPES, BIDIRECTIONAL (EWBE2)**

Copy the second Electromagnetic Waves, Beam Envelopes physics interface.

In the **Model Builder** window, under **Component 1 (comp1)** right-click **Electromagnetic Waves, Beam Envelopes, Bidirectional (ewbe2)** and choose **Copy**.

### **ELECTROMAGNETIC WAVES, BEAM ENVELOPES, BIDIRECTIONAL, MODE EXPANSION**

- 1 In the **Model Builder** window, right-click **Component 1 (comp1)** and choose **Paste Electromagnetic Waves, Beam Envelopes**.
- 2 In the **Messages from Paste** dialog box, click **OK**.
- 3 In the **Settings** window for **Electromagnetic Waves, Beam Envelopes**, type **Electromagnetic Waves, Beam Envelopes, Bidirectional, Mode Expansion** in the **Label** text field.

### **DEFINITIONS**

#### *Variables 3*

- 1 In the **Model Builder** window, under **Component 1 (comp1)** right-click **Definitions** and choose **Variables**, to define expressions for the excited ports' input powers and mode phases.



- 2 In the **Settings** window for **Variables**, locate the **Variables** section.
- 3 In the table, enter the following settings:

Name	Expression	Unit	Description
Pin1	$\text{abs}(\text{intop1}(\text{Etarget} * \text{conj}(\text{ewbe3.tH0modey}_1)))^2 / \text{abs}(4 * \text{ewbe3.Pmode}_1)$	W	
ph1	$\text{arg}(\text{intop1}(\text{Etarget} * \text{conj}(\text{ewbe3.tH0modey}_1))) / \text{ewbe3.Pmode}_1$	rad	
Pin2	$\text{abs}(\text{intop1}(\text{Etarget} * \text{conj}(\text{ewbe3.tH0modey}_2)))^2 / \text{abs}(4 * \text{ewbe3.Pmode}_2)$	W	
ph2	$\text{arg}(\text{intop1}(\text{Etarget} * \text{conj}(\text{ewbe3.tH0modey}_2))) / \text{ewbe3.Pmode}_2$	rad	

### ELECTROMAGNETIC WAVES, BEAM ENVELOPES, BIDIRECTIONAL, MODE EXPANSION (EWBE3)

Now, set the ports' input powers and mode phases to the defined expressions.


#### Port 1

- 1 In the **Model Builder** window, expand the **Electromagnetic Waves, Beam Envelopes, Bidirectional, Mode Expansion (ewbe3)** node, then click **Port 1**.
- 2 In the **Settings** window for **Port**, locate the **Port Properties** section.
- 3 In the  $P_{\text{in}}$  text field, type Pin1.
- 4 Locate the **Port Mode Settings** section. In the  $\theta_{\text{in}}$  text field, type ph1.


#### Port 2

- 1 In the **Model Builder** window, click **Port 2**.
- 2 In the **Settings** window for **Port**, locate the **Port Properties** section.
- 3 In the  $P_{\text{in}}$  text field, type Pin2.
- 4 Locate the **Port Mode Settings** section. In the  $\theta_{\text{in}}$  text field, type ph2.

### ADD STUDY

- 1 In the **Home** toolbar, click  **Add Study** to open the **Add Study** window.
- 2 Go to the **Add Study** window.
- 3 Find the **Studies** subsection. In the **Select Study** tree, select **Empty Study**.
- 4 Click **Add Study** in the window toolbar.

## STUDY, BIDIRECTIONAL, MODE EXPANSION

- 1 In the **Settings** window for **Study**, type **Study, Bidirectional, Mode Expansion** in the **Label** text field.
- 2 In the **Home** toolbar, click  **Add Study** to close the **Add Study** window.

## STUDY, BIDIRECTIONAL

*Step 1: Boundary Mode Analysis, Step 2: Boundary Mode Analysis 1, Step 3: Boundary Mode Analysis 2, Step 4: Boundary Mode Analysis 3, Step 5: Frequency Domain*

- 1 In the **Model Builder** window, under **Study, Bidirectional**, Ctrl-click to select **Step 1: Boundary Mode Analysis, Step 2: Boundary Mode Analysis 1, Step 3: Boundary Mode Analysis 2, Step 4: Boundary Mode Analysis 3, and Step 5: Frequency Domain**.
- 2 Right-click and choose **Copy**.

## STUDY, BIDIRECTIONAL, MODE EXPANSION

*Step 1: Boundary Mode Analysis*

- 1 In the **Model Builder** window, right-click **Study, Bidirectional, Mode Expansion** and choose **Paste Multiple Items**.
- 2 In the **Settings** window for **Boundary Mode Analysis**, locate the **Physics and Variables Selection** section.
- 3 In the table, clear the **Solve for** check box for **Electromagnetic Waves, Beam Envelopes, Bidirectional (ewbe2)**.

*Step 2: Boundary Mode Analysis 1*

- 1 In the **Model Builder** window, click **Step 2: Boundary Mode Analysis 1**.
- 2 In the **Settings** window for **Boundary Mode Analysis**, locate the **Physics and Variables Selection** section.
- 3 In the table, clear the **Solve for** check box for **Electromagnetic Waves, Beam Envelopes, Bidirectional (ewbe2)**.


*Step 3: Boundary Mode Analysis 2*

- 1 In the **Model Builder** window, click **Step 3: Boundary Mode Analysis 2**.
- 2 In the **Settings** window for **Boundary Mode Analysis**, locate the **Physics and Variables Selection** section.
- 3 In the table, clear the **Solve for** check box for **Electromagnetic Waves, Beam Envelopes, Bidirectional (ewbe2)**.

#### Step 4: Boundary Mode Analysis 3

- 1 In the **Model Builder** window, click **Step 4: Boundary Mode Analysis 3**.
- 2 In the **Settings** window for **Boundary Mode Analysis**, locate the **Physics and Variables Selection** section.
- 3 In the table, clear the **Solve for** check box for **Electromagnetic Waves, Beam Envelopes, Bidirectional (ewbe2)**.

#### Step 5: Frequency Domain

- 1 In the **Model Builder** window, click **Step 5: Frequency Domain**.
- 2 In the **Settings** window for **Frequency Domain**, locate the **Physics and Variables Selection** section.
- 3 In the table, clear the **Solve for** check box for **Electromagnetic Waves, Beam Envelopes, Bidirectional (ewbe2)**.
- 4 In the **Home** toolbar, click  **Compute**.

## RESULTS

#### Electric Field, Bidirectional, Mode Expansion

- 1 In the **Settings** window for **3D Plot Group**, type Electric Field, Bidirectional, Mode Expansion in the **Label** text field.

Modify the default Multislice plot to make it appear similar to the previous Slice plots.

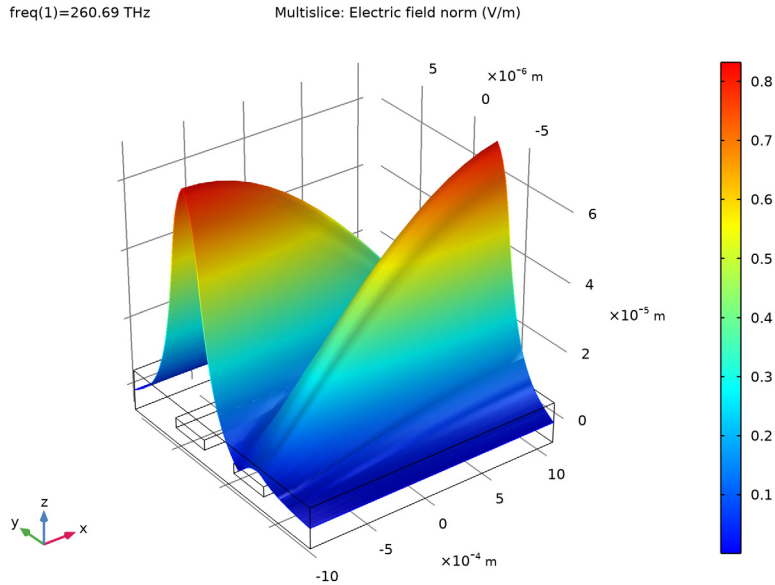
#### Electric Field

- 1 In the **Model Builder** window, expand the **Electric Field, Bidirectional, Mode Expansion** node, then click **Electric Field**.
- 2 In the **Settings** window for **Multislice**, locate the **Multiplane Data** section.
- 3 Find the **X-planes** subsection. In the **Planes** text field, type 0.
- 4 Find the **Y-planes** subsection. In the **Planes** text field, type 0.
- 5 Click to expand the **Quality** section. From the **Smoothing** list, choose **Everywhere**.

#### Deformation 1


- 1 Right-click **Electric Field** and choose **Deformation**.
- 2 In the **Settings** window for **Deformation**, locate the **Expression** section.
- 3 In the **Z component** text field, type  $ewbe3.normE$ .

4 In the **Electric Field, Bidirectional, Mode Expansion** toolbar, click  **Plot**.



It is clear that the input beam approximates the target field. Add a plot showing the difference between the target field and the actual field.

*Electric Field, Difference Between Actual and Target*

- 1 In the **Home** toolbar, click  **Add Plot Group** and choose **3D Plot Group**.
- 2 In the **Settings** window for **3D Plot Group**, type **Electric Field, Difference Between Actual and Target** in the **Label** text field.
- 3 Locate the **Data** section. From the **Dataset** list, choose **Study, Bidirectional, Mode Expansion/Solution 11 (sol11)**.

*Surface 1*

- 1 Right-click **Electric Field, Difference Between Actual and Target** and choose **Surface**.
- 2 In the **Settings** window for **Surface**, locate the **Expression** section.
- 3 In the **Expression** text field, type **Etarget**.

*Deformation 1*

- 1 Right-click **Surface 1** and choose **Deformation**.
- 2 In the **Settings** window for **Deformation**, locate the **Expression** section.
- 3 In the **X component** text field, type **-Etarget**.

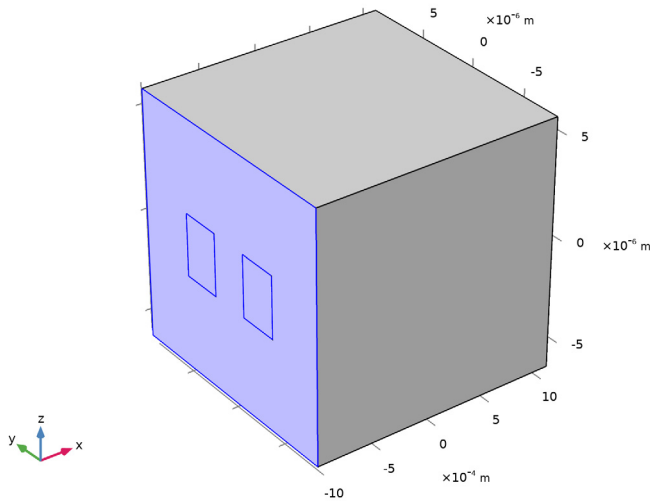
- 4 Locate the **Scale** section. Select the **Scale factor** check box.
- 5 In the associated text field, type 1E-3.

#### Surface 2

- 1 In the **Model Builder** window, right-click **Electric Field, Difference Between Actual and Target** and choose **Surface**.
- 2 In the **Settings** window for **Surface**, locate the **Expression** section.
- 3 In the **Expression** text field, type  $ewbE3.Ez$ .
- 4 Click to expand the **Inherit Style** section. From the **Plot** list, choose **Surface 1**.


#### Selection 1

- 1 Right-click **Surface 2** and choose **Selection**.
- 2 Select Boundaries 1, 5, and 10 only.

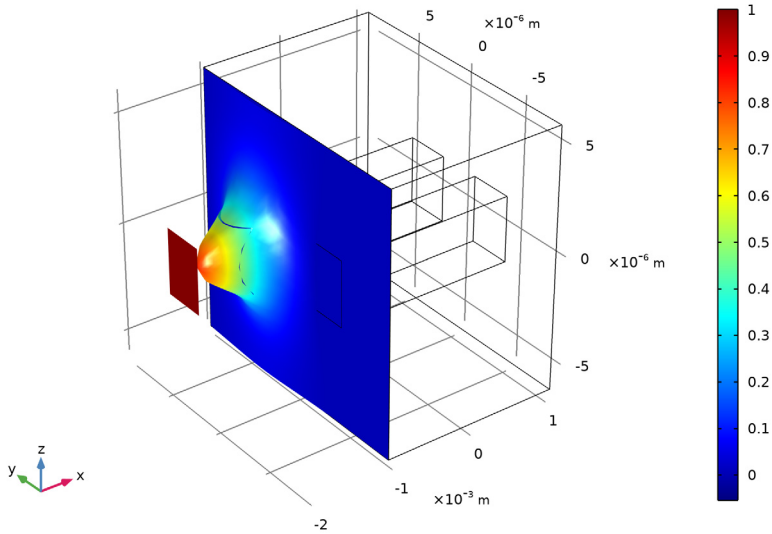


#### Deformation 1

- 1 In the **Model Builder** window, right-click **Surface 2** and choose **Deformation**.
- 2 In the **Settings** window for **Deformation**, locate the **Expression** section.
- 3 In the **X component** text field, type  $-ewbE3.Ez$ .

4 In the **Electric Field, Difference Between Actual and Target** toolbar, click  **Plot**.

freq(1)=260.69 THz Surface: Target electric field (V/m) Surface: Electric field, z component (V/m)



Again, this plot shows that the two modes are superposed to approximate the target field.

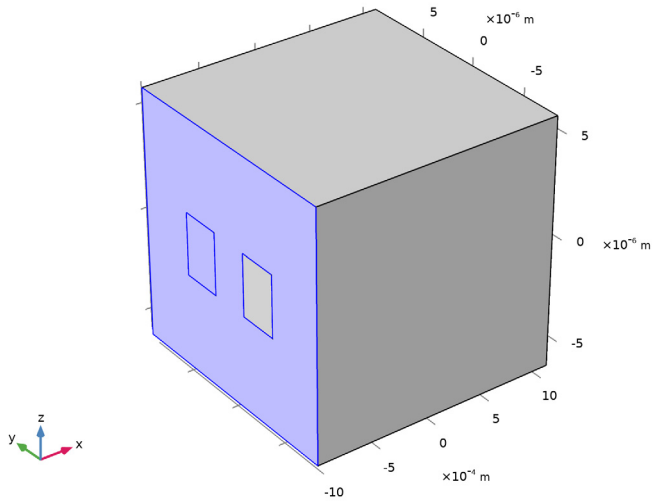
#### DEFINITIONS

To verify that the superposed modes approximate the target field, let the target field now represent a wave launched in the right waveguide.

*Variables 1*

1 In the **Model Builder** window, under **Component 1 (comp1)>Definitions** click **Variables 1**.

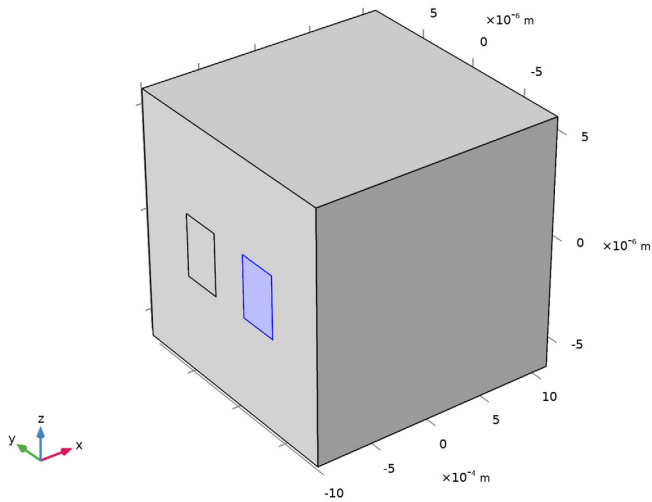
2 Select Boundaries 1 and 10 only.




*Variables 2*

1 In the **Model Builder** window, click **Variables 2**.

2 Select Boundary 5 only.



3 In the **Home** toolbar, click  **Compute**.

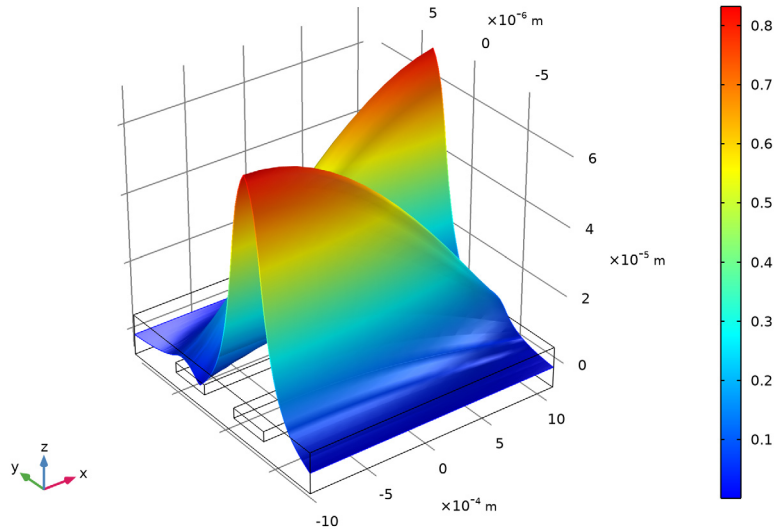
## RESULTS

### *Electric Field, Bidirectional, Mode Expansion*

I In the **Electric Field, Bidirectional, Mode Expansion** toolbar, click  **Plot**.

freq(1)=260.69 THz

Multislice: Electric field norm (V/m)



The input wave now appear at the right waveguide, as expected.

### *Electric Field, Difference Between Actual and Target*

I In the **Model Builder** window, click **Electric Field, Difference Between Actual and Target**.



2 In the **Electric Field, Difference Between Actual and Target** toolbar, click  **Plot**.

freq(1)=260.69 THz Surface: Target electric field (V/m) Surface: Electric field, z component (V/m)

