



Fresnel Equations

Introduction

A plane electromagnetic wave propagating through free space is incident at an angle upon an infinite dielectric medium. This model computes the reflection and transmission coefficients and compares the results to the Fresnel equations.

Model Definition

A plane wave propagating through free space ($n = 1$) as shown in Figure 1 is incident upon an infinite dielectric medium ($n = 1.5$) and is partially reflected and partially transmitted. If the electric field is *p-polarized* — that is, if the electric field vector is in the same plane as the Poynting vector and the surface normal — then there are no reflections at an incident angle of roughly 56° , known as the *Brewster angle*.

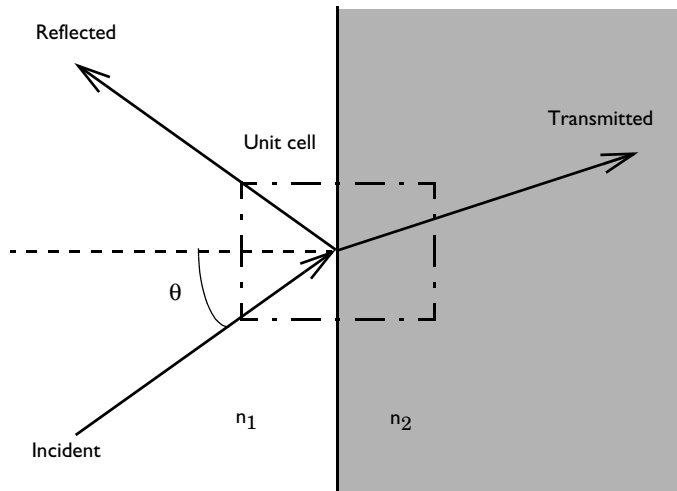

Figure 1: A plane wave propagating through free space incident upon an infinite dielectric medium.

Although, by assumption, space extends to infinity in all directions, it is sufficient to model a small unit cell, as shown in Figure 1; a Floquet-periodic boundary condition applies on the top and bottom unit-cell boundaries because the solution is periodic along the interface. This model uses a 3D unit cell and applies also a periodic boundary condition in the out-of-plane direction. However, this periodic boundary condition acts like a continuity condition. The angle of incidence ranges between $0-90^\circ$ for both polarizations.

For comparison, Ref. 1 and Ref. 2 provide analytic expressions for the reflectance and transmittance¹. Reflection and transmission coefficients for s-polarization and p-polarization are defined respectively as

$$r_s = \frac{n_1 \cos \theta_{\text{incident}} - n_2 \cos \theta_{\text{transmitted}}}{n_1 \cos \theta_{\text{incident}} + n_2 \cos \theta_{\text{transmitted}}}$$

$$t_s = \frac{2n_1 \cos \theta_{\text{incident}}}{n_1 \cos \theta_{\text{incident}} + n_2 \cos \theta_{\text{transmitted}}}$$

$$r_p = \frac{n_2 \cos \theta_{\text{incident}} - n_1 \cos \theta_{\text{transmitted}}}{n_1 \cos \theta_{\text{transmitted}} + n_2 \cos \theta_{\text{incident}}}$$

$$t_p = \frac{2n_1 \cos \theta_{\text{incident}}}{n_1 \cos \theta_{\text{transmitted}} + n_2 \cos \theta_{\text{incident}}}$$

Reflectance and transmittance are defined as

$$R = |r|^2$$

$$T = \frac{n_2 \cos \theta_{\text{transmitted}}}{n_1 \cos \theta_{\text{incident}}} |t|^2$$

The Brewster angle at which $r_p = 0$ is defined as

$$\theta_B = \text{atan} \frac{n_2}{n_1}$$

1. Note that depending on the sign convention for what is defined as a positive polarization for the reflected wave with in-plane (p-polarization), the sign for the reflection coefficient r_p can differ for different authors. However, the total field solution will always be the same.

Results and Discussion

Figure 2 is a combined plot of the y component of the electric-field distribution and the power flow visualized as an arrow plot for the TE case.

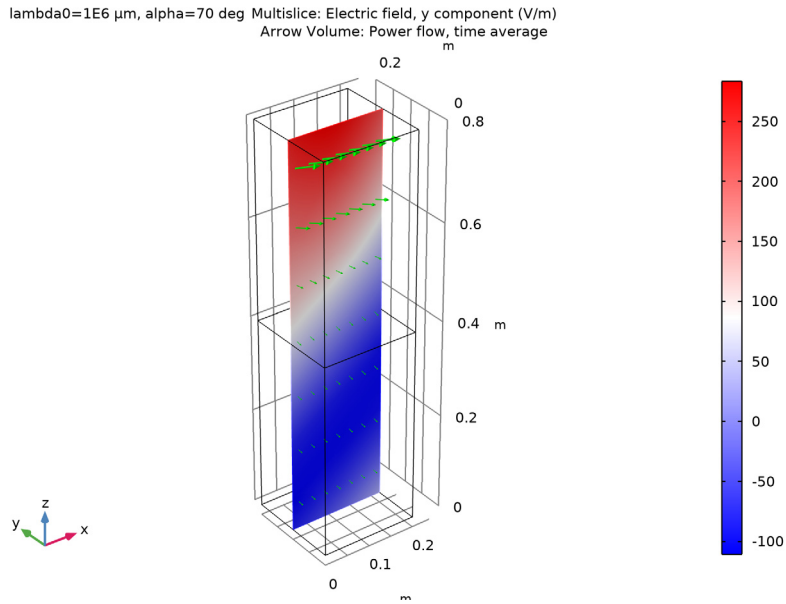

Figure 2: Electric field, E_y (slice) and power flow (arrows) for TE incidence at 70° inside the unit cell.

For the TM case, [Figure 3](#) visualizes the y component of the magnetic-field distribution instead, again in combination with the power flow.

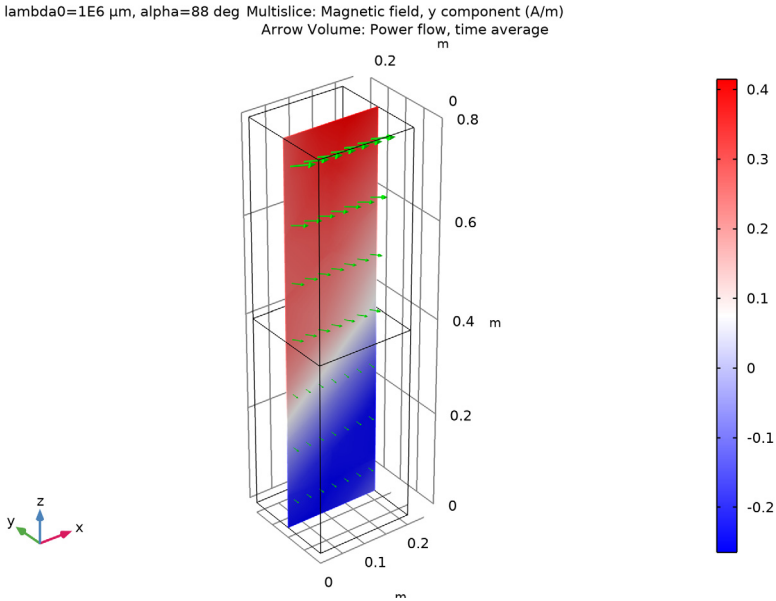

Figure 3: Magnetic field, H_y (slice) and power flow (arrows) for TM incidence at 70° inside the unit cell.

Note that the sum of reflectance and transmittance in [Figure 4](#) and [Figure 5](#) equals 1, showing conservation of power. [Figure 5](#) also shows that the reflectance around 56° — the Brewster angle in the TM case — is close to zero.

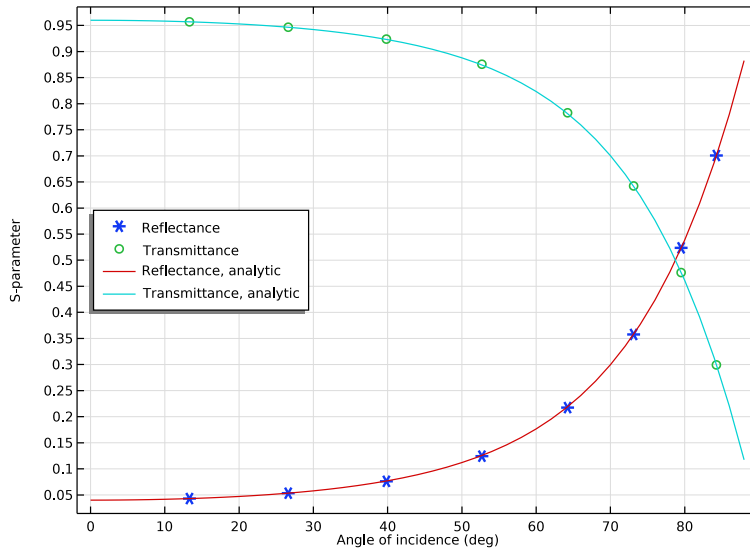

Figure 4: The reflectance and transmittance for TE incidence agree well with the analytic solutions.

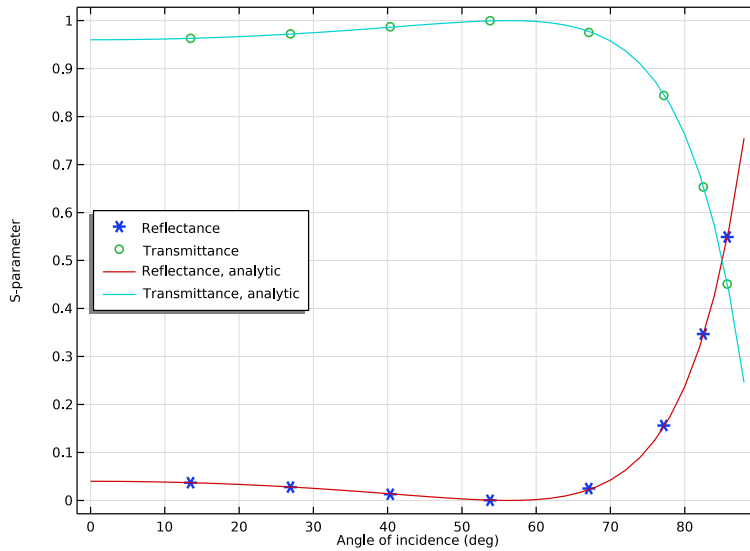

Figure 5: The reflectance and transmittance for TM incidence agree well with the analytic solutions. The Brewster angle is also observed at the expected location.

References

1. J.D. Jackson, *Classical Electrodynamics*, 3rd Ed., Wiley, 1999.
 2. B.E.A. Saleh and M.C. Teich, *Fundamentals of Photonics*, Wiley, 1991.
-

Application Library path: RF_Module/Verification_Examples/
fresnel_equations



Modeling Instructions

From the **File** menu, choose **New**.

NEW

In the **New** window, click  **Model Wizard**.

MODEL WIZARD

- 1 In the **Model Wizard** window, click  **3D**.
- 2 In the **Select Physics** tree, select **Radio Frequency>Electromagnetic Waves, Frequency Domain (emw)**.
- 3 Click **Add**.
- 4 Click  **Study**.
- 5 In the **Select Study** tree, select **General Studies>Frequency Domain**.
- 6 Click  **Done**.

GLOBAL DEFINITIONS

Define some parameters that are useful when setting up the geometry and the study.

Parameters 1

- 1 In the **Model Builder** window, under **Global Definitions** click **Parameters 1**.
- 2 In the **Settings** window for **Parameters**, locate the **Parameters** section.

3 In the table, enter the following settings:

Name	Expression	Value	Description
n_air	1	1	Refractive index, air
n_slab	1.5	1.5	Refractive index, slab
lda0	1[m]	1 m	Wavelength
f0	c_const/lda0	2.9979E8 1/s	Frequency
alpha	70[deg]	1.2217 rad	Angle of incidence
beta	asin(n_air*sin(alpha)/n_slab)	0.67701 rad	Refraction angle
alpha_brewster	atan(n_slab/n_air)	0.98279 rad	Brewster angle, TM only
r_s	$(n_air \cdot \cos(\alpha) - n_slab \cdot \cos(\beta)) / (n_air \cdot \cos(\alpha) + n_slab \cdot \cos(\beta))$	-0.54735	Reflection coefficient, TE
r_p	$(n_slab \cdot \cos(\alpha) - n_air \cdot \cos(\beta)) / (n_air \cdot \cos(\beta) + n_slab \cdot \cos(\alpha))$	-0.20613	Reflection coefficient, TM
t_s	$(2 \cdot n_air \cdot \cos(\alpha)) / (n_air \cdot \cos(\alpha) + n_slab \cdot \cos(\beta))$	0.45265	Transmission coefficient, TE
t_p	$(2 \cdot n_air \cdot \cos(\alpha)) / (n_air \cdot \cos(\beta) + n_slab \cdot \cos(\alpha))$	0.52925	Transmission coefficient, TM

The angle of incidence is updated while running the parametric sweep. The refraction (transmitted) angle is defined by Snell's law with the updated angle of incidence. The Brewster angle exists only for TM incidence, p-polarization (polarization is in the plane of incidence).

STUDY 1 (TE)

1 In the **Model Builder** window, click **Study 1**.

2 In the **Settings** window for **Study**, type Study 1 (TE) in the **Label** text field.

Step 1: Frequency Domain

1 In the **Model Builder** window, under **Study 1 (TE)** click **Step 1: Frequency Domain**.

- 2 In the **Settings** window for **Frequency Domain**, locate the **Study Settings** section.
- 3 In the **Frequencies** text field, type f_0 .



GEOMETRY I

First, create a block composed of two domains. Use layers to split the block.

Block 1 (blk1)

- 1 In the **Geometry** toolbar, click  **Block**.
- 2 In the **Settings** window for **Block**, locate the **Size and Shape** section.
- 3 In the **Width** text field, type 0.2.
- 4 In the **Depth** text field, type 0.2.
- 5 In the **Height** text field, type 0.8.
- 6 Click to expand the **Layers** section. In the table, enter the following settings:

Layer name	Thickness (m)
Layer 1	0.4

- 7 Click  **Build All Objects**.
- 8 Click the  **Zoom Extents** button in the **Graphics** toolbar.

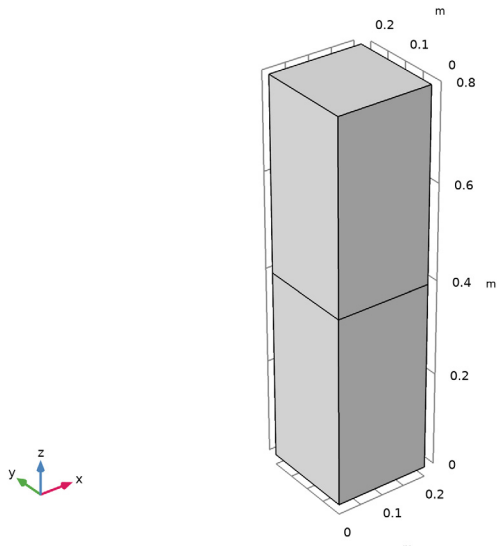

Choose wireframe rendering to get a better view of each boundary.

- 9 Click the  **Wireframe Rendering** button in the **Graphics** toolbar.

ELECTROMAGNETIC WAVES, FREQUENCY DOMAIN (EMW)

Set up the physics based on the direction of propagation and the E-field polarization. First, assume a TE-polarized wave which is equivalent to s-polarization or perpendicular polarization. E_x and E_z are zero while E_y is dominant.

Wave Equation, Electric I

- 1 In the **Model Builder** window, under **Component 1 (comp1)>Electromagnetic Waves, Frequency Domain (emw)** click **Wave Equation, Electric I**.
- 2 In the **Settings** window for **Wave Equation, Electric**, locate the **Electric Displacement Field** section.
- 3 From the **Electric displacement field model** list, choose **Refractive index**.
- 4 In the **Model Builder** window, click **Electromagnetic Waves, Frequency Domain (emw)**.
- 5 In the **Settings** window for **Electromagnetic Waves, Frequency Domain**, type **Electromagnetic Waves, Frequency Domain (TE)** in the **Label** text field.

Port 1

- 1 In the **Physics** toolbar, click  **Boundaries** and choose **Port**.
- 2 Select Boundary 7 only.
- 3 In the **Settings** window for **Port**, locate the **Port Properties** section.
- 4 From the **Type of port** list, choose **Periodic**.
For the first port, wave excitation is **on** by default.
- 5 Locate the **Port Mode Settings** section. Specify the \mathbf{E}_0 vector as

0	x
1	y
0	z

- 6 Locate the **Automatic Diffraction Order Calculation** section. In the n text field, type n_{air} .
- 7 Locate the **Port Mode Settings** section. In the α_1 text field, type α .
The maximum frequency in the setting window will be used only when **Compute Diffraction Order** button is clicked to generate **Diffraction Order** features representing higher order modes. In this model, no diffraction is expected from the given geometry, so this setting is ineffective.

Port 2

- 1 In the **Physics** toolbar, click  **Boundaries** and choose **Port**.

- 2 Select Boundary 3 only.
- 3 In the **Settings** window for **Port**, locate the **Port Properties** section.
- 4 From the **Type of port** list, choose **Periodic**.
- 5 Locate the **Port Mode Settings** section. Specify the \mathbf{E}_0 vector as

0	x
1	y
0	z

- 6 Locate the **Automatic Diffraction Order Calculation** section. In the n text field, type n_{slab} .
The bottom surface is an observation port. The S_{21} -parameter from Port 1 and Port 2 provides the transmission characteristics.

Periodic Condition 1

- 1 In the **Physics** toolbar, click  **Boundaries** and choose **Periodic Condition**.
- 2 Select Boundaries 1, 4, 10, and 11 only.
- 3 In the **Settings** window for **Periodic Condition**, locate the **Periodicity Settings** section.
- 4 From the **Type of periodicity** list, choose **Floquet periodicity**.
- 5 From the **k-vector for Floquet periodicity** list, choose **From periodic port**.

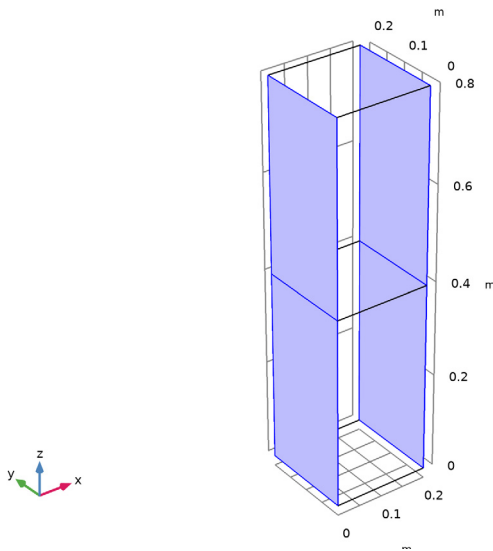

Periodic Condition 2

- 1 In the **Physics** toolbar, click  **Boundaries** and choose **Periodic Condition**.
- 2 Select Boundaries 2, 5, 8, and 9 only.
- 3 In the **Settings** window for **Periodic Condition**, locate the **Periodicity Settings** section.
- 4 From the **Type of periodicity** list, choose **Floquet periodicity**.
- 5 From the **k-vector for Floquet periodicity** list, choose **From periodic port**.

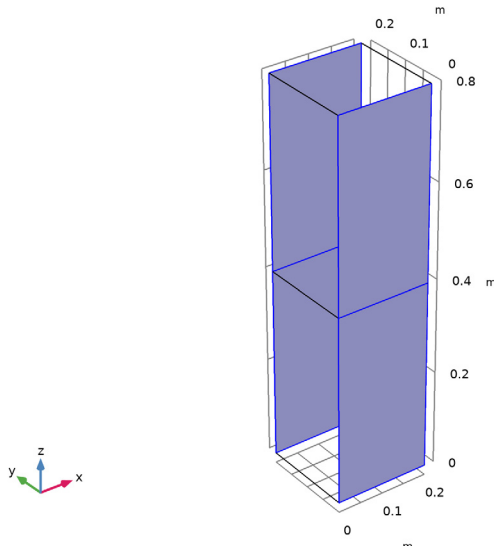

MATERIALS

Now set up the material properties based on refractive index. The top half is filled with air.

Air

- 1 In the **Model Builder** window, under **Component 1 (comp1)** right-click **Materials** and choose **Blank Material**.
- 2 In the **Settings** window for **Material**, type Air in the **Label** text field.
- 3 Select Domain 2 only.

4 Locate the **Material Contents** section. In the table, enter the following settings:

Property	Variable	Value	Unit	Property group
Refractive index, real part	n_{iso} ; $n_{ii} = n_{iso}$, $n_{ij} = 0$	n_{air}	l	Refractive index
Refractive index, imaginary part	$k_{i_{iso}}$; $k_{iii} =$ $k_{i_{iso}}$, $k_{ij} = 0$	0	l	Refractive index

Glass

The bottom half is glass.

1 Right-click **Materials** and choose **Blank Material**.

2 In the **Settings** window for **Material**, type Glass in the **Label** text field.

3 Select Domain 1 only.

4 Locate the **Material Contents** section. In the table, enter the following settings:

Property	Variable	Value	Unit	Property group
Refractive index, real part	n_{iso} ; $n_{ii} = n_{iso}$, $n_{ij} = 0$	n_{slab}	l	Refractive index
Refractive index, imaginary part	$k_{i_{iso}}$; $k_{iii} =$ $k_{i_{iso}}$, $k_{ij} = 0$	0	l	Refractive index

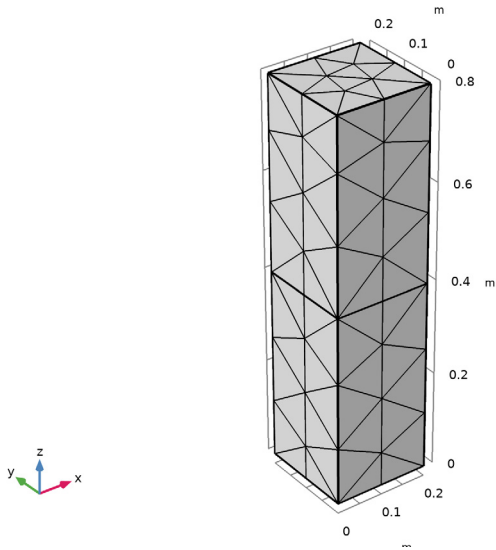

MESH 1

In the **Model Builder** window, under **Component 1 (comp1)** right-click **Mesh 1** and choose **Build All**.



STUDY 1 (TE)

Parametric Sweep

- 1 In the **Study** toolbar, click  **Parametric Sweep**.
- 2 In the **Settings** window for **Parametric Sweep**, locate the **Study Settings** section.
- 3 Click  **Add**.
- 4 In the table, enter the following settings:

Parameter name	Parameter value list	Parameter unit
alpha (Angle of incidence)	range(0,2[deg],88[deg])	deg

- 5 In the **Study** toolbar, click  **Compute**.

RESULTS

Electric Field (emw, TE)

- 1 In the **Settings** window for **3D Plot Group**, type **Electric Field (emw, TE)** in the **Label** text field.

The default plot is the E-field norm for the last solution, which corresponds to almost tangential incidence. Replace the expression with E_y , add an arrow plot of the power flow (Poynting vector), and choose a more interesting angle of incidence for the plot.

Multislice

- 1 In the **Model Builder** window, expand the **Electric Field (emw, TE)** node, then click **Multislice**.
- 2 In the **Settings** window for **Multislice**, click **Replace Expression** in the upper-right corner of the **Expression** section. From the menu, choose **Component 1 (comp1)> Electromagnetic Waves, Frequency Domain (TE)>Electric>Electric field - V/m>emw.Ey - Electric field, y component**.
- 3 Locate the **Multipane Data** section. Find the **X-planes** subsection. In the **Planes** text field, type 0.
- 4 Find the **Z-planes** subsection. In the **Planes** text field, type 0.
- 5 Locate the **Coloring and Style** section. From the **Color table** list, choose **WaveLight**.

Arrow Volume 1

- 1 In the **Model Builder** window, right-click **Electric Field (emw, TE)** and choose **Arrow Volume**.
- 2 In the **Settings** window for **Arrow Volume**, click **Replace Expression** in the upper-right corner of the **Expression** section. From the menu, choose **Component 1 (comp1)> Electromagnetic Waves, Frequency Domain (TE)>Energy and power>emw.Poavx,..., emw.Poavz - Power flow, time average**.
- 3 Locate the **Arrow Positioning** section. Find the **Y grid points** subsection. In the **Points** text field, type 1.
- 4 Locate the **Coloring and Style** section. From the **Color** list, choose **Green**.

Electric Field (emw, TE)

- 1 In the **Model Builder** window, click **Electric Field (emw, TE)**.
- 2 In the **Settings** window for **3D Plot Group**, locate the **Data** section.
- 3 From the **Parameter value (alpha (deg))** list, choose **70**.
- 4 In the **Electric Field (emw, TE)** toolbar, click  **Plot**.

5 Click the  **Zoom Extends** button in the **Graphics** toolbar.

alpha(36)=70 deg Multislice: Electric field, y component (V/m) Arrow Volume: Power flow, time average

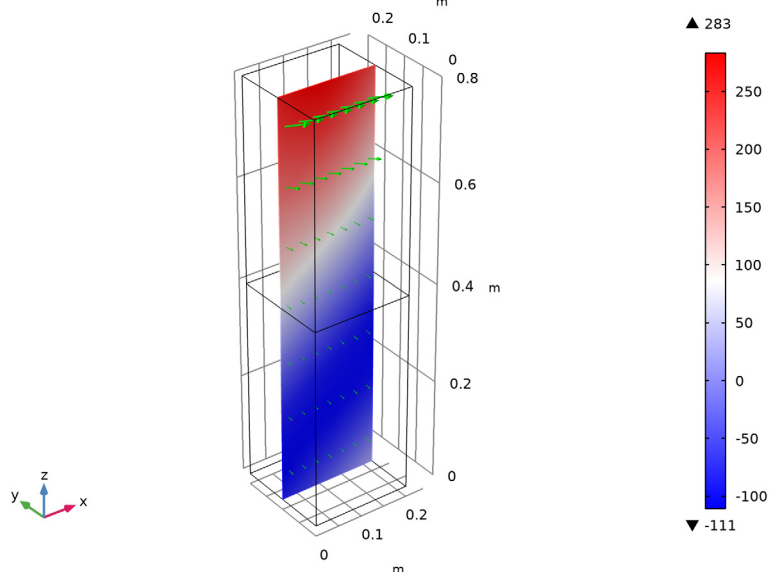

The plot should look like that in [Figure 2](#).

S-Parameter (emw, TE)

A 1D plot with the reflection and transmission versus the angle of incidence is added by default.

- 1 In the **Model Builder** window, under **Results** click **S-parameter (emw)**.
- 2 In the **Settings** window for **ID Plot Group**, type S-Parameter (emw, TE) in the **Label** text field.
- 3 Click to expand the **Title** section. From the **Title type** list, choose **None**.
- 4 Locate the **Plot Settings** section. Select the **x-axis label** check box.
Replace the dB-scale variables with the linear-scale S-parameter variables.
- 5 In the **y-axis label** text field, type S-parameter.
- 6 Locate the **Legend** section. From the **Position** list, choose **Middle left**.

Global 1

- 1 In the **Model Builder** window, expand the **S-Parameter (emw, TE)** node, then click **Global 1**.
- 2 In the **Settings** window for **Global**, locate the **y-Axis Data** section.

3 In the table, enter the following settings:

Expression	Unit	Description
$\text{abs}(\text{emw.S11})^2$	1	Reflectance
$\text{abs}(\text{emw.S21})^2$	1	Transmittance

4 In the **S-Parameter (emw, TE)** toolbar, click  **Plot**.

5 Click to expand the **Coloring and Style** section. Find the **Line style** subsection. From the **Line** list, choose **None**.

6 Find the **Line markers** subsection. From the **Marker** list, choose **Cycle**.

Global 2

1 In the **Model Builder** window, right-click **S-Parameter (emw, TE)** and choose **Global**.

2 In the **Settings** window for **Global**, locate the **y-Axis Data** section.

3 In the table, enter the following settings:

Expression	Unit	Description
$\text{abs}(r_s)^2$		Reflectance, analytic
$n_{\text{slab}} \cdot \cos(\beta) / (n_{\text{air}} \cdot \cos(\alpha)) \cdot \text{abs}(t_s)^2$		Transmittance, analytic

4 Locate the **x-Axis Data** section. From the **Unit** list, choose $^\circ$.

5 In the **S-Parameter (emw, TE)** toolbar, click  **Plot**.

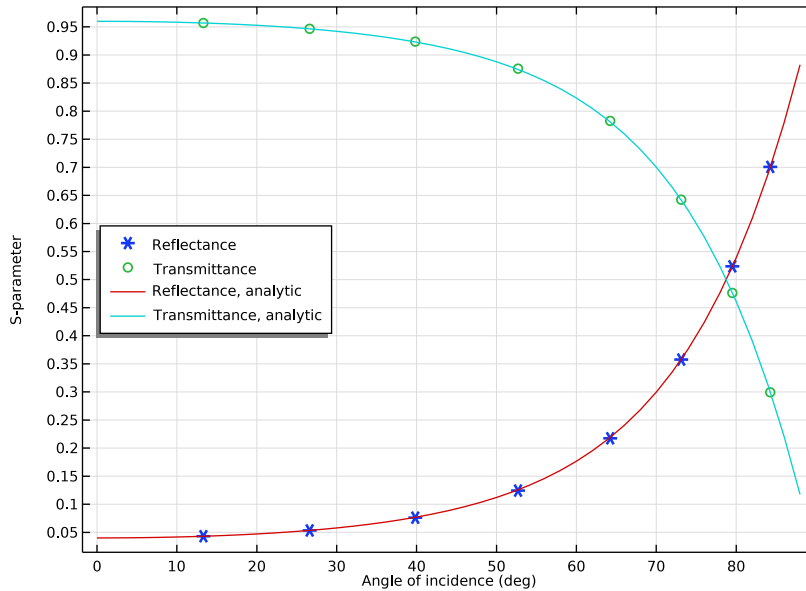

Compare the resulting plots with [Figure 4](#).

Smith Plot (emw, TE)

- 1 In the **Model Builder** window, under **Results** click **Smith Plot (emw)**.
- 2 In the **Settings** window for **Smith Plot Group**, type Smith Plot (emw, TE) in the **Label** text field.
- 3 In the **Model Builder** window, expand the **Smith Plot (emw, TE)** node.

Color Expression 1

- 1 In the **Model Builder** window, expand the **Results>Smith Plot (emw, TE)>Reflection Graph 1** node, then click **Color Expression 1**.
- 2 In the **Settings** window for **Color Expression**, locate the **Expression** section.
- 3 In the **Expression** text field, type α .
- 4 From the **Unit** list, choose $^\circ$.

Smith Plot (emw, TE)

- 1 In the **Model Builder** window, click **Smith Plot (emw, TE)**.
- 2 In the **Settings** window for **Smith Plot Group**, click to expand the **Title** section.
- 3 From the **Title type** list, choose **Manual**.

- 4 In the **Title** text area, type Reflection Graph: S-parameter, Color: Angle of incidence (deg).
- 5 In the **Smith Plot (emw, TE)** toolbar, click  **Plot**.

Polarization Plot (emw, TE)

- 1 In the **Model Builder** window, under **Results** click **Polarization Plot (emw)**.
- 2 In the **Settings** window for **ID Plot Group**, type Polarization Plot (emw, TE) in the **Label** text field.
- 3 In the **Polarization Plot (emw, TE)** toolbar, click  **Plot**.

The polarization plot shows that the field is linearly polarized, with a pure out-of-plane polarization. The out-of-plane component of the Jones vector represents the amplitude of a wave polarized in the y direction, whereas the in-plane component represents the amplitude of a wave with a polarization that is orthogonal to both the out-of-plane direction and the propagation direction, resulting in a polarization in the $x - z$ plane.

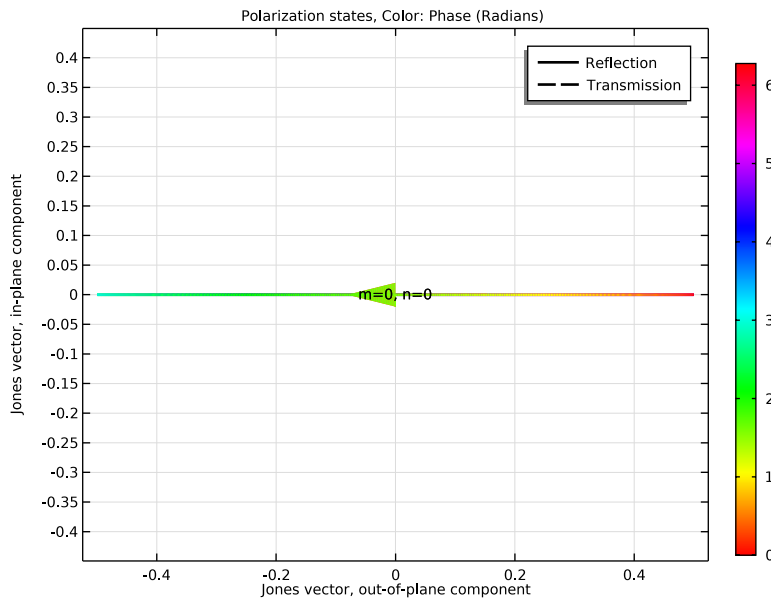

ELECTROMAGNETIC WAVES, FREQUENCY DOMAIN (TE) (EMW)

The following instructions are for the case of a TM-polarized wave (p-polarization or parallel polarization). In this case, E_y is zero while E_x and E_z characterize the wave. In other words, H_y is dominant while H_x and H_z have no effect. Thus, the H-field is

perpendicular to the plane of incidence and it is convenient to specify the port mode fields as the H-field.

In the **Model Builder** window, under **Component 1 (comp1)** right-click **Electromagnetic Waves, Frequency Domain (TE) (emw)** and choose **Copy**.

ELECTROMAGNETIC WAVES, FREQUENCY DOMAIN (TM)

- 1 In the **Model Builder** window, right-click **Component 1 (comp1)** and choose **Paste Electromagnetic Waves, Frequency Domain**.
- 2 In the **Messages from Paste** dialog box, click **OK**.
- 3 In the **Settings** window for **Electromagnetic Waves, Frequency Domain**, type **Electromagnetic Waves, Frequency Domain (TM)** in the **Label** text field.

STUDY 1 (TE)

Step 1: Frequency Domain

- 1 In the **Model Builder** window, under **Study 1 (TE)** click **Step 1: Frequency Domain**.
- 2 In the **Settings** window for **Frequency Domain**, locate the **Physics and Variables Selection** section.
- 3 In the table, enter the following settings:

Physics interface	Solve for	Discretization
Electromagnetic Waves, Frequency Domain (TE) (emw)	√	Physics settings
Electromagnetic Waves, Frequency Domain (TM) (emw2)		Physics settings

ELECTROMAGNETIC WAVES, FREQUENCY DOMAIN (TM) (EMW2)

Port 1

- 1 In the **Model Builder** window, expand the **Component 1 (comp1)>Electromagnetic Waves, Frequency Domain (TM) (emw2)** node, then click **Port 1**.
- 2 In the **Settings** window for **Port**, locate the **Port Mode Settings** section.
- 3 From the **Input quantity** list, choose **Magnetic field**.
- 4 Specify the \mathbf{H}_0 vector as

$$\begin{matrix} \underline{\hspace{1cm}} \\ 0 & \times \\ \underline{\hspace{1cm}} \end{matrix}$$



1	y
0	z

Port 2

- 1 In the **Model Builder** window, click **Port 2**.
- 2 In the **Settings** window for **Port**, locate the **Port Mode Settings** section.
- 3 From the **Input quantity** list, choose **Magnetic field**.
- 4 Specify the \mathbf{H}_0 vector as

0	x
1	y
0	z

ADD STUDY

- 1 In the **Home** toolbar, click  **Add Study** to open the **Add Study** window.
- 2 Go to the **Add Study** window.
- 3 Find the **Studies** subsection. In the **Select Study** tree, select **General Studies> Frequency Domain**.
- 4 Click **Add Study** in the window toolbar.
- 5 In the **Home** toolbar, click  **Add Study** to close the **Add Study** window.

STUDY 2



Step 1: Frequency Domain

- 1 In the **Settings** window for **Frequency Domain**, locate the **Study Settings** section.
- 2 In the **Frequencies** text field, type f_0 .
- 3 Locate the **Physics and Variables Selection** section. In the table, enter the following settings:

Physics interface	Solve for	Discretization
Electromagnetic Waves, Frequency Domain (TE) (emw)		Physics settings
Electromagnetic Waves, Frequency Domain (TM) (emw2)	√	Physics settings

- 4 In the **Model Builder** window, click **Study 2**.
- 5 In the **Settings** window for **Study**, type Study 2 (TM) in the **Label** text field.

Parametric Sweep

- 1 In the **Study** toolbar, click  **Parametric Sweep**.
- 2 In the **Settings** window for **Parametric Sweep**, locate the **Study Settings** section.
- 3 Click  **Add**.
- 4 In the table, enter the following settings:

Parameter name	Parameter value list	Parameter unit
alpha (Angle of incidence)	range (0, 2 [deg] , 88 [deg])	deg

- 5 In the **Study** toolbar, click  **Compute**.

RESULTS

Magnetic Field (emw2, TM)

In the **Settings** window for **3D Plot Group**, type Magnetic Field (emw2, TM) in the **Label** text field.

Multislice

- 1 In the **Model Builder** window, expand the **Magnetic Field (emw2, TM)** node, then click **Multislice**.
- 2 In the **Settings** window for **Multislice**, locate the **Expression** section.
- 3 In the **Expression** text field, type $emw2.Hy$.
- 4 Locate the **Multiplane Data** section. Find the **X-planes** subsection. In the **Planes** text field, type 0.
- 5 Find the **Z-planes** subsection. In the **Planes** text field, type 0.
- 6 Locate the **Coloring and Style** section. From the **Color table** list, choose **WaveLight**.

Arrow Volume 1

- 1 In the **Model Builder** window, right-click **Magnetic Field (emw2, TM)** and choose **Arrow Volume**.
- 2 In the **Settings** window for **Arrow Volume**, locate the **Expression** section.
- 3 In the **X component** text field, type $emw2.Poavx$.
- 4 In the **Y component** text field, type $emw2.Poavy$.
- 5 In the **Z component** text field, type $emw2.Poavz$.
- 6 Locate the **Arrow Positioning** section. Find the **Y grid points** subsection. In the **Points** text field, type 1.
- 7 Locate the **Coloring and Style** section. From the **Color** list, choose **Green**.

8 In the **Magnetic Field (emw2, TM)** toolbar, click  **Plot**.

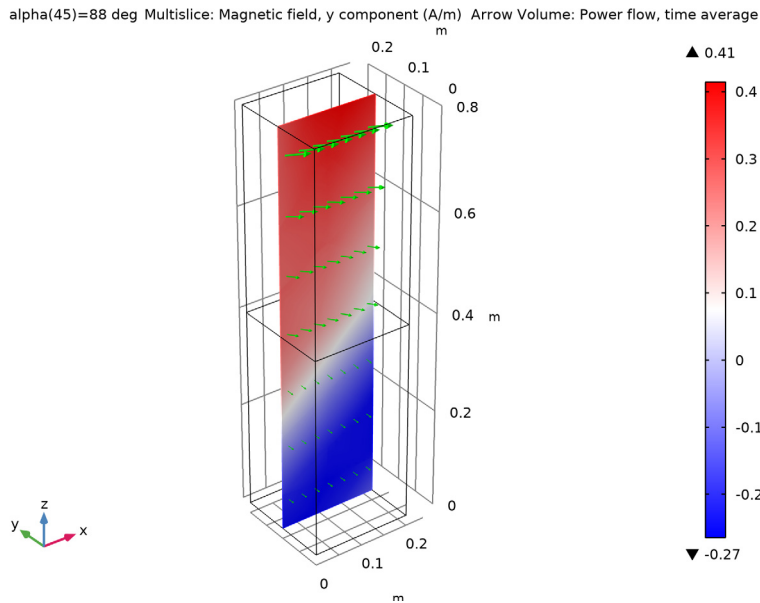

This reproduces [Figure 3](#).

S-Parameter (emw2, TM)

- 1 In the **Model Builder** window, under **Results** click **S-parameter (emw2)**.
- 2 In the **Settings** window for **ID Plot Group**, type S-Parameter (emw2, TM) in the **Label** text field.
- 3 Locate the **Title** section. From the **Title type** list, choose **None**.
- 4 Locate the **Plot Settings** section. Select the **x-axis label** check box.
- 5 In the **y-axis label** text field, type S-parameter.
- 6 Locate the **Legend** section. From the **Position** list, choose **Middle left**.

Global 1

- 1 In the **Model Builder** window, expand the **S-Parameter (emw2, TM)** node, then click **Global 1**.
- 2 In the **Settings** window for **Global**, locate the **y-Axis Data** section.

3 In the table, enter the following settings:

Expression	Unit	Description
$\text{abs}(\text{emw2.S11})^2$	1	Reflectance
$\text{abs}(\text{emw2.S21})^2$	1	Transmittance

4 Locate the **Coloring and Style** section. Find the **Line style** subsection. From the **Line** list, choose **None**.

5 Find the **Line markers** subsection. From the **Marker** list, choose **Cycle**.

Global 2

1 In the **Model Builder** window, right-click **S-Parameter (emw2, TM)** and choose **Global**.

2 In the **Settings** window for **Global**, locate the **y-Axis Data** section.

3 In the table, enter the following settings:

Expression	Unit	Description
$\text{abs}(r_p)^2$		Reflectance, analytic
$n_{\text{slab}} \cdot \cos(\beta) / (n_{\text{air}} \cdot \cos(\alpha)) \cdot \text{abs}(t_p)^2$		Transmittance, analytic

4 Locate the **x-Axis Data** section. From the **Unit** list, choose °.

5 In the **S-Parameter (emw2, TM)** toolbar, click  **Plot**.

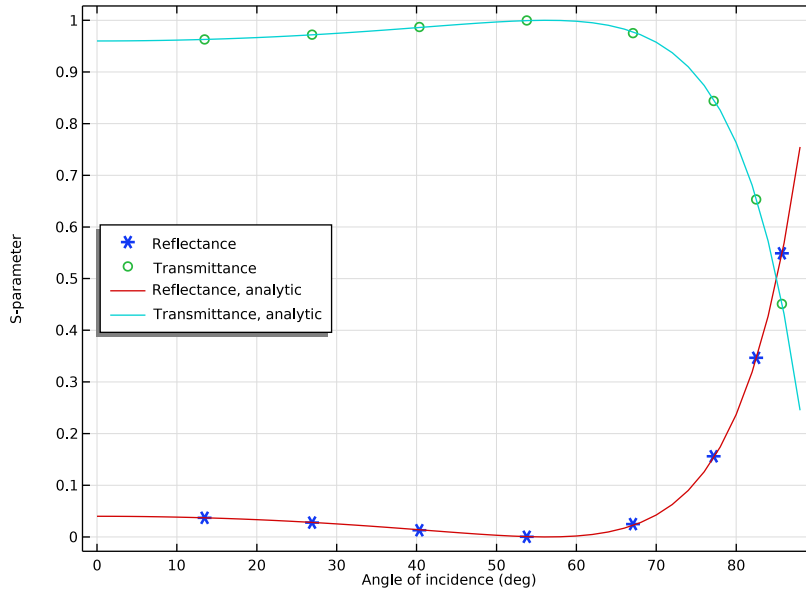

The plot should look like [Figure 5](#). The Brewster angle is observed around 56 degrees, which is close to the analytic value.

Smith Plot (emw2, TM)

- 1 In the **Model Builder** window, under **Results** click **Smith Plot (emw2)**.
- 2 In the **Settings** window for **Smith Plot Group**, type Smith Plot (emw2, TM) in the **Label** text field.
- 3 In the **Model Builder** window, expand the **Smith Plot (emw2, TM)** node.

Color Expression 1

- 1 In the **Model Builder** window, expand the **Results>Smith Plot (emw2, TM)>Reflection Graph 1** node, then click **Color Expression 1**.
- 2 In the **Settings** window for **Color Expression**, locate the **Expression** section.
- 3 In the **Expression** text field, type α .
- 4 From the **Unit** list, choose $^\circ$.

Smith Plot (emw2, TM)

- 1 In the **Model Builder** window, click **Smith Plot (emw2, TM)**.
- 2 In the **Settings** window for **Smith Plot Group**, locate the **Title** section.

- 3 From the **Title type** list, choose **Manual**.
- 4 In the **Title** text area, type Reflection Graph: S-parameter, Color: Angle of incidence (deg).
- 5 In the **Smith Plot (emw2, TM)** toolbar, click  **Plot**.

Polarization Plot (emw2, TM)

- 1 In the **Model Builder** window, under **Results** click **Polarization Plot (emw2)**.
- 2 In the **Settings** window for **ID Plot Group**, type Polarization Plot (emw2, TM) in the **Label** text field.
- 3 In the **Polarization Plot (emw2, TM)** toolbar, click  **Plot**.

Also in this case, the polarization plot shows that the field is linearly polarized, in this case with a pure in-plane polarization.

