



# Elastoplastic Analysis of Holed Plate

## Introduction

---

In this example you analyze a perforated plate loaded into the plastic regime. In addition to the original problem, which you can find in section 7.10 of *The Finite Element Method* by O.C. Zienkiewicz (Ref. 1), you can also study the unloading of the plate.

The model also shows how to apply an external hardening function based on an interpolated stress-strain curve.

## Model Definition

---

Figure 1 shows the plate's geometry. Due to the double symmetry of the geometry you only need to analyze a quarter of the plate.

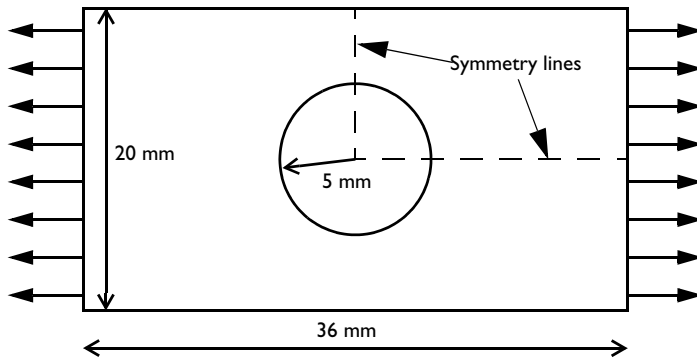

Figure 1: The plate geometry.

Because the plate is thin and the loads are in plane, you can assume a plane stress condition.

### MATERIAL

- Elastic properties:  $E = 70000$  MPa and  $\nu = 0.2$ .
- Plastic properties: Yield stress 243 MPa and a linear isotropic hardening with tangent modulus 2171 MPa.

### CONSTRAINTS AND LOADS

- Symmetry plane constraints are applied on the leftmost vertical boundary and the lower horizontal boundary.

- The right vertical edge is subjected to a stress, which increases from zero to a maximum value of 133.65 MPa and then is released again. The peak value is selected so that the mean stress over the section through the hole is 10% above the yield stress ( $=1.1 \cdot 243 \cdot (20-10)/20$ ).

### *Results and Discussion*

---

Figure 2 shows the development of the plastic region. The parameter values are 0.55, 0.65, 0.75, 0.85, 0.95, and 1.05. These values are proportional to the load with a parameter value 1.0, which corresponds to the yield limit of the average stress over the cross section through the hole. For a material without strain hardening, the structure would thus have collapsed before reaching the final load level. Because an elastoplastic solution is load-path dependent, it is important not to use too large steps in the load parameter when you anticipate a plastic flow. Usually you can take one large step up to the elastic limit, as this example shows. Moreover, reversed plastic flow can occur during the unloading. This is why this study uses small parameter steps at the end of the parameter range.

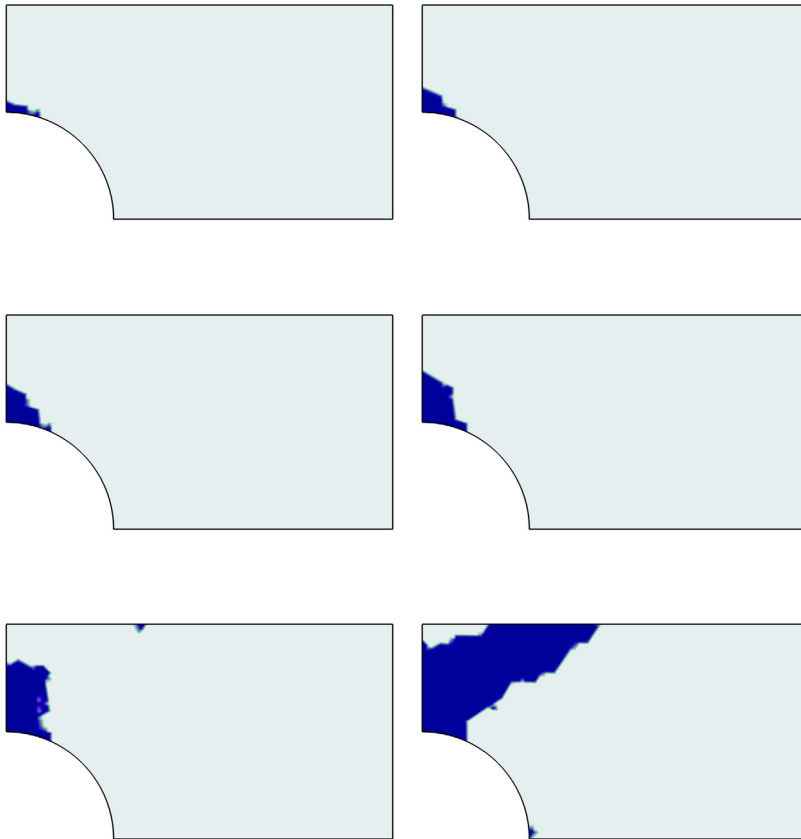

*Figure 2: Development of plastic region (red) for parameter values 0.55, 0.65, 0.75, 0.85, 0.95 and 1.05.*

### *Modeling with COMSOL Multiphysics*

---

In this example there are two studies where the only difference is how the hardening data of the plasticity model is entered. In the first study, you give the data in the most natural way, since a linear hardening can be entered directly using the tangent modulus.

In the second study, it is shown how to proceed when you have a tabulated data from a general tensile test. Note that in metal plasticity, the hardening function  $\sigma_h$  to be entered

is the stress added to the initial yield stress  $\sigma_{ys0}$  as function of the equivalent plastic strain  $\epsilon_{pe}$ . Thus, the function must always pass the point (0,0). If your tabulated data contains total stress versus total strain, the hardening function must thus be written as

$$\sigma_h(\epsilon_{pe}) = \sigma_{tab}(\epsilon_{pe} + \sigma_e/E) - \sigma_{ys0}$$

where,  $\sigma_e$  is the equivalent (von Mises) stress,  $E$  is the Young's modulus, and  $\sigma_{tab}$  is an interpolation function of your tabulated data. Figure 4 shows the linear elastic and plastic regions.

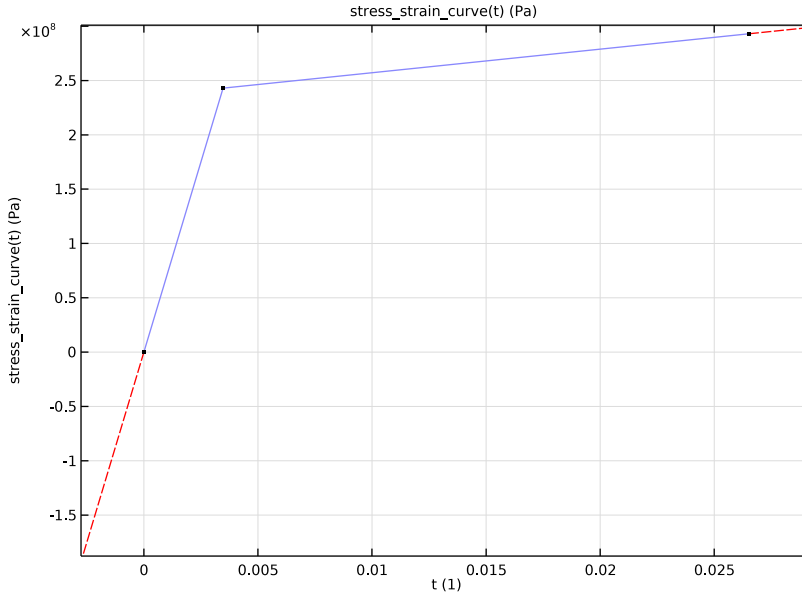

Figure 3: The interpolated stress-strain curve shows both the elastic and hardening regions.

The results show in Figure 4 and Figure 5 are in good agreement. In Study 1, isotropic hardening is generated with an isotropic tangent modulus  $E_{Tiso} = 2.171$  GPa, and in Study 2 it is generated with interpolated hardening function data, which mimics the isotropic tangent modulus from Study 1.

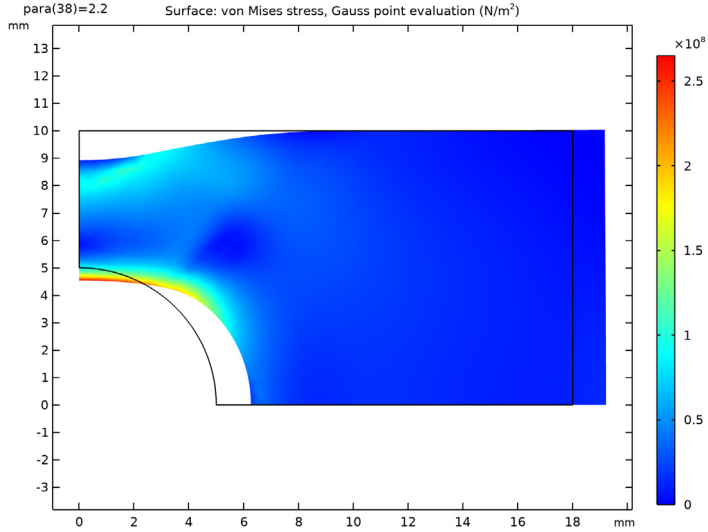

Figure 4: Deformation and von Mises stress for parameter value 2.2. The hardening was implemented with isotropic tangent modulus  $E_{T_{iso}} = 2.171$  GPa.

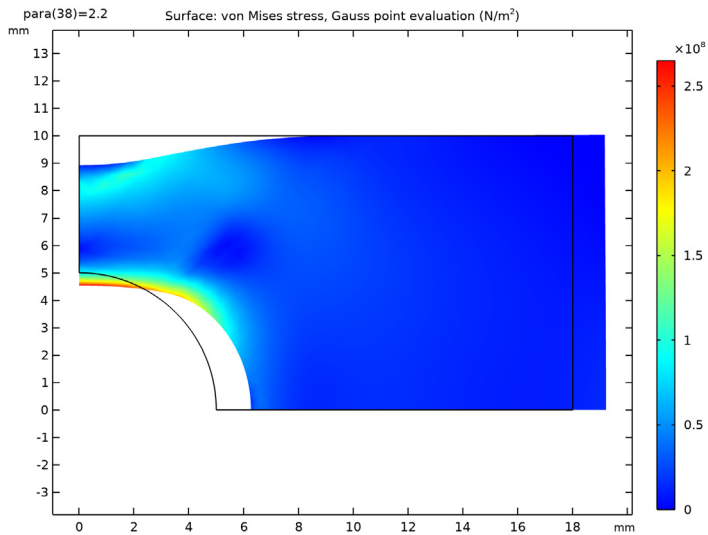

Figure 5: Deformation and von Mises stress for parameter value 2.2. The hardening was implemented with the interpolated hardening function.

## Reference

---

1. O.C. Zienkiewicz and R.L. Taylor, *The Finite Element Method*, 4th ed., McGraw-Hill, 1991.

---

**Application Library path:** Nonlinear\_Structural\_Materials\_Module/  
Plasticity/elastoplastic\_plate

---

## Modeling Instructions



---

From the **File** menu, choose **New**.

### NEW

In the **New** window, click  **Model Wizard**.

### MODEL WIZARD

- 1 In the **Model Wizard** window, click  **2D**.
- 2 In the **Select Physics** tree, select **Structural Mechanics>Solid Mechanics (solid)**.
- 3 Click **Add**.
- 4 Click  **Study**.
- 5 In the **Select Study** tree, select **General Studies>Stationary**.
- 6 Click  **Done**.

### GEOMETRY I

Begin by changing the length unit to millimeters.



- 1 In the **Model Builder** window, under **Component 1 (comp1)** click **Geometry 1**.
- 2 In the **Settings** window for **Geometry**, locate the **Units** section.
- 3 From the **Length unit** list, choose **mm**.

#### *Rectangle 1 (r1)*



- 1 In the **Geometry** toolbar, click  **Rectangle**.
- 2 In the **Settings** window for **Rectangle**, locate the **Size and Shape** section.
- 3 In the **Width** text field, type 18.
- 4 In the **Height** text field, type 10.

5 Click  **Build Selected**.

*Circle 1 (c1)*

- 1 In the **Geometry** toolbar, click  **Circle**.
- 2 In the **Settings** window for **Circle**, locate the **Size and Shape** section.
- 3 In the **Radius** text field, type 5.
- 4 Click  **Build Selected**.

*Difference 1 (dif1)*

- 1 In the **Geometry** toolbar, click  **Booleans and Partitions** and choose **Difference**.
- 2 Select the object **r1** only.
- 3 In the **Settings** window for **Difference**, locate the **Difference** section.
- 4 Find the **Objects to subtract** subsection. Select the  **Activate Selection** toggle button.
- 5 Select the object **c1** only.
- 6 Click  **Build Selected**.

Add a solver parameter for controlling the load expression.

## GLOBAL DEFINITIONS

*Parameters 1*

- 1 In the **Model Builder** window, under **Global Definitions** click **Parameters 1**.
- 2 In the **Settings** window for **Parameters**, locate the **Parameters** section.
- 3 In the table, enter the following settings:

Name	Expression	Value	Description
para	0	0	Horizontal load parameter

## DEFINITIONS

*Interpolation 1 (int1)*

- 1 In the **Home** toolbar, click  **Functions** and choose **Local>Interpolation**.
- 2 In the **Settings** window for **Interpolation**, locate the **Definition** section.
- 3 In the **Function name** text field, type loadfunc.



4 In the table, enter the following settings:

<b>t</b>	<b>f(t)</b>
0	0
1.1	133.65
2.2	0

5 Locate the **Units** section. In the **Arguments** text field, type 1.

6 In the **Function** text field, type MPa.

7 Click  **Plot**.

The interpolation function defines the load function.

### **SOLID MECHANICS (SOLID)**

1 In the **Model Builder** window, under **Component 1 (comp1)** click **Solid Mechanics (solid)**.

2 In the **Settings** window for **Solid Mechanics**, locate the **2D Approximation** section.

3 From the list, choose **Plane stress**.

4 Locate the **Thickness** section. In the  $d$  text field, type 10[mm].

#### *Linear Elastic Material 1*

In the **Model Builder** window, under **Component 1 (comp1)>Solid Mechanics (solid)** click **Linear Elastic Material 1**.

#### *Linear Hardening*

1 In the **Physics** toolbar, click  **Attributes** and choose **Plasticity**.

2 In the **Settings** window for **Plasticity**, type Linear Hardening in the **Label** text field.

### **MATERIALS**

#### *Material 1 (mat1)*

1 In the **Model Builder** window, under **Component 1 (comp1)** right-click **Materials** and choose **Blank Material**.

2 In the **Settings** window for **Material**, locate the **Material Contents** section.

3 In the table, enter the following settings:

Property	Variable	Value	Unit	Property group
Young's modulus	E	70e9	Pa	Basic
Poisson's ratio	nu	0.2	I	Basic
Density	rho	7850	kg/m <sup>3</sup>	Basic
Initial yield stress	sigmags	243e6	Pa	Elastoplastic material model
Isotropic tangent modulus	Et	2.171e9	Pa	Elastoplastic material model

### SOLID MECHANICS (SOLID)

#### Symmetry 1

- 1 In the **Physics** toolbar, click  **Boundaries** and choose **Symmetry**.
- 2 Select Boundaries 1 and 3 only.

#### Boundary Load 1

- 1 In the **Physics** toolbar, click  **Boundaries** and choose **Boundary Load**.
- 2 Select Boundary 4 only.
- 3 In the **Settings** window for **Boundary Load**, locate the **Force** section.
- 4 Specify the  $\mathbf{F}_A$  vector as

loadfunc (para)	x
0	y

### MESH 1

#### Free Triangular 1

- 1 In the **Mesh** toolbar, click  **Free Triangular**.

The mesh should be refined in areas of anticipated high stress and strain gradients.

#### Refine 1

- 1 In the **Mesh** toolbar, click  **Modify** and choose **Elements>Refine**.
- 2 In the **Settings** window for **Refine**, click to expand the **Refine Elements in Box** section.
- 3 Select the **Specify bounding box** check box.

- 4 In row **x**, set **Upper bound** to 8.
- 5 In row **y**, set **Upper bound** to 10.
- 6 In the **Model Builder** window, right-click **Mesh 1** and choose **Build All**.  
The mesh should consist of around 700 elements.

## STUDY 1

### *Step 1: Stationary*

Set up an auxiliary continuation sweep for the para parameter.

- 1 In the **Model Builder** window, under **Study 1** click **Step 1: Stationary**.
- 2 In the **Settings** window for **Stationary**, click to expand the **Study Extensions** section.
- 3 Select the **Auxiliary sweep** check box.
- 4 Click **+ Add**.
- 5 In the table, enter the following settings:

Parameter name	Parameter value list
para (Horizontal load parameter)	0 range (0.40,0.05,2.2)

With these settings, the edge load you defined earlier increases from zero to a maximum value of 133.65 MPa and is then released.

- 6 In the **Model Builder** window, click **Study 1**.
- 7 In the **Settings** window for **Study**, type **Linear Hardening** in the **Label** text field.
- 8 In the **Home** toolbar, click **= Compute**.

## RESULTS

The first default plot shows the von Mises stress for the final parameter value.

### *Stress, Linear Hardening*

- 1 In the **Model Builder** window, under **Results** click **Stress (solid)**.
- 2 In the **Settings** window for **2D Plot Group**, type **Stress, Linear Hardening** in the **Label** text field.

Visualize the plastic zone using a Boolean expression `solid.epeGp>0` which is 1 in the plastic region and 0 elsewhere.

### *Plastic Region, Linear Hardening*

- 1 In the **Model Builder** window, under **Results** click **Equivalent Plastic Strain (solid)**.

- 2 In the **Settings** window for **2D Plot Group**, type Plastic Region, Linear Hardening in the **Label** text field.

#### *Contour 1*

- 1 In the **Model Builder** window, expand the **Plastic Region, Linear Hardening** node, then click **Contour 1**.
- 2 In the **Settings** window for **Contour**, locate the **Expression** section.
- 3 In the **Expression** text field, type `solid.epεGp>0`.

#### *Plastic Region, Linear Hardening*

- 1 In the **Model Builder** window, click **Plastic Region, Linear Hardening**.
- 2 In the **Settings** window for **2D Plot Group**, locate the **Data** section.
- 3 From the **Parameter value (para)** list, choose **0.55**.
- 4 In the **Plastic Region, Linear Hardening** toolbar, click  **Plot**.

The plot in the **Graphics** window should now look like that in the upper-left panel of [Figure 2](#).

- 5 Repeat steps 3, 4 and 5 for **Parameter value (para)** 0.65, 0.75, 0.85, 0.95, and 1.05 to reproduce the remaining subplots in [Figure 2](#).

### *Hardening with Experimental Stress-Strain Curve and user defined yield function.*

---

To fit the first study case, the stress-strain curve will be very simple, an elastic slope of 70 GPa and then a plastic slope of 2.171 GPa. Only three points are needed to define the stress-strain curve in this simple case.

#### **DEFINITIONS**

##### *Interpolation 2 (int2)*

- 1 In the **Home** toolbar, click  **Functions** and choose **Local>Interpolation**.
- 2 In the **Settings** window for **Interpolation**, locate the **Definition** section.
- 3 In the **Function name** text field, type `stress_strain_curve`.
- 4 In the table, enter the following settings:

<b>t</b>	<b>f(t)</b>
0	0

t	f(t)
243e6/70e9	243e6
243e6/70e9+50e6/2.171e9	243e6+50e6

- Locate the **Units** section. In the **Arguments** text field, type 1.
- In the **Function** text field, type Pa.
- Locate the **Interpolation and Extrapolation** section. From the **Extrapolation** list, choose **Linear**.
- Click  **Plot**.

Add a variable for controlling the hardening.

#### *Variables I*

- In the **Home** toolbar, click  **Variables** and choose **Local Variables**.
- In the **Settings** window for **Variables**, locate the **Variables** section.
- In the table, enter the following settings:

Name	Expression	Unit	Description
hardening	max(0, stress_strain_curve(solid.epe+solid.mises/solid.E)-solid.sigmags)	Pa	Hardening function

## **SOLID MECHANICS (SOLID)**

### *Linear Elastic Material I*

In the **Model Builder** window, under **Component I (comp1)>Solid Mechanics (solid)** click **Linear Elastic Material I**.

### *Interpolated Hardening and User Defined Plastic Flow*

- In the **Physics** toolbar, click  **Attributes** and choose **Plasticity**.
- In the **Settings** window for **Plasticity**, type Interpolated Hardening and User Defined Plastic Flow in the **Label** text field.  
Define the von Mises stress in terms of the second invariant of the stress tensor.
- Locate the **Plasticity Model** section. From the **Yield function F** list, choose **User defined**.
- In the  $\phi(\sigma)$  text field, type  $\text{sqrt}(3*\text{solid.II2sEff})$ .  
Add a small value to the potential to avoid possible division of zero when evaluating its derivative at zero stress.
- From the **Plastic potential Q** list, choose **User defined**.

- 6 In the  $Q$  text field, type `sqrt(3*solid.II2sEff+eps)`.  
Use hardening function data and add the hardening function to the material properties.
- 7 Find the **Isotropic hardening model** subsection. From the list, choose **Hardening function**.



## MATERIALS

### Material 1 (mat1)

- 1 In the **Model Builder** window, expand the **Interpolated Hardening and User Defined Plastic Flow** node, then click **Component 1 (comp1)>Materials>Material 1 (mat1)**.
- 2 In the **Settings** window for **Material**, locate the **Material Contents** section.
- 3 In the table, enter the following settings:

Property	Variable	Value	Unit	Property group
Hardening function	sigmagh	hardening	Pa	Elastoplastic material model

## ADD STUDY

- 1 In the **Home** toolbar, click  **Add Study** to open the **Add Study** window.
- 2 Go to the **Add Study** window.
- 3 Find the **Studies** subsection. In the **Select Study** tree, select **General Studies>Stationary**.
- 4 Click **Add Study** in the window toolbar.
- 5 In the **Home** toolbar, click  **Add Study** to close the **Add Study** window.

## STUDY 2

### Step 1: Stationary

- 1 In the **Settings** window for **Stationary**, locate the **Study Extensions** section.
- 2 Select the **Auxiliary sweep** check box.
- 3 Click **+ Add**.
- 4 In the table, enter the following settings:

Parameter name	Parameter value list
para (Horizontal load parameter)	0 range (0.40,0.05,2.2)

The solver settings are the same as in the previous study.

- 5 In the **Model Builder** window, click **Study 2**.

6 In the **Settings** window for **Study**, type Interpolated Hardening and User Defined Plastic Flow in the **Label** text field.

7 In the **Home** toolbar, click  **Compute**.

## RESULTS

### *Stress, Interpolated Hardening and User Defined Plastic Flow*

The first default plot of the second study shows the von Mises stress for the final parameter value.

1 In the **Settings** window for **2D Plot Group**, type Stress, Interpolated Hardening and User Defined Plastic Flow in the **Label** text field.

### *Plastic Region, Interpolated Hardening and User Defined Plastic Flow*

1 In the **Model Builder** window, under **Results** click **Equivalent Plastic Strain (solid)**.

2 In the **Settings** window for **2D Plot Group**, type Plastic Region, Interpolated Hardening and User Defined Plastic Flow in the **Label** text field.

### *Contour 1*

1 In the **Model Builder** window, expand the **Plastic Region, Interpolated Hardening and User Defined Plastic Flow** node, then click **Contour 1**.

2 In the **Settings** window for **Contour**, locate the **Expression** section.

3 In the **Expression** text field, type `solid.epεGp>0`.

The analysis is now finished. If you want to store this model and re-use it later, you will need to disable the second plasticity feature for the first study.

## LINEAR HARDENING

### *Step 1: Stationary*

1 In the **Model Builder** window, under **Linear Hardening** click **Step 1: Stationary**.

2 In the **Settings** window for **Stationary**, locate the **Physics and Variables Selection** section.

3 Select the **Modify model configuration for study step** check box.

4 In the **Physics and variables selection** tree, select **Component 1 (comp1)> Solid Mechanics (solid)>Linear Elastic Material 1> Interpolated Hardening and User Defined Plastic Flow**.

5 Click  **Disable**.

