



Automotive Muffler

Introduction

This example describes the pressure wave propagation in a muffler for an explosion engine. The approach is general for analysis of damping of harmonic pressure waves.

The purpose of the application is to show how to treat 3D acoustics in a fairly complex geometry consisting of several separate sections and pipes divided by thin perfectly rigid walls. The analysis gives the transmission loss in the frequency range 100 Hz–1000 Hz.

Model Definition

The model geometry consists of three separate resonator chambers divided by thin walls. The inlet and the outlet correspond to the connection in the direction of the engine and of free air, respectively.

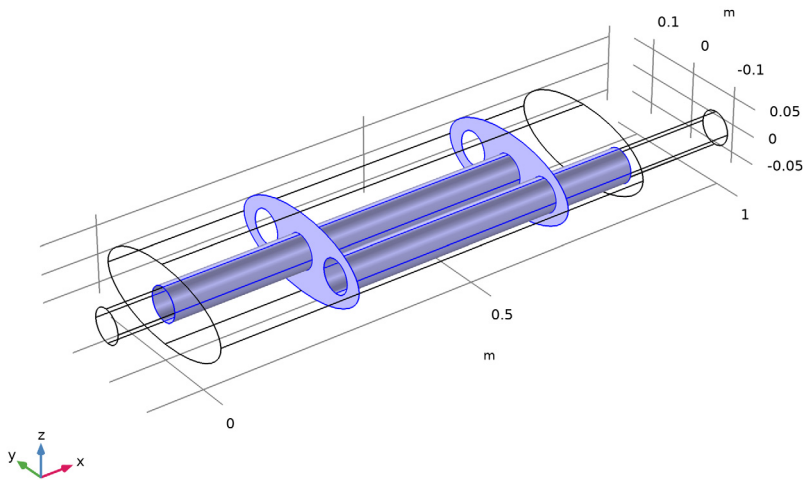

Figure 1: The geometry of a muffler. The exhaust fumes enter through the left pipe, pass the three resonator chambers, and exit through the right pipe.

DOMAIN EQUATIONS

You solve the problem in the frequency domain using the Pressure Acoustics, Frequency Domain interface. The model equation is a slightly modified Helmholtz equation for the acoustic pressure p :

$$\nabla \cdot \left(-\frac{\nabla p}{\rho} \right) - \frac{\omega^2 p}{c^2 \rho} = 0$$

where ρ is the density, c is the speed of sound, and ω is the angular frequency. The density needs to be included in the equation in cases where variations in density in different materials exist. The model assumes that in the low-frequency range, reactive damping prevails. Resistive damping is therefore not included.

BOUNDARY CONDITIONS

The boundary conditions are of three different types. At all the solid boundaries, which include the outer walls of the muffler, the dividing walls between the resonator chambers, and the walls of the pipes, sound hard (wall) boundary conditions are used:

$$\left(-\frac{\nabla p}{\rho} \right) \cdot \mathbf{n} = 0$$

At the inlet boundary, a combination of an incoming and an outgoing plane waves is assumed:

$$\left(-\frac{\nabla p}{\rho} \right) \cdot \mathbf{n} = \frac{i\omega}{\rho c} p - \frac{2i\omega}{\rho c} p_0$$

In this equation p_0 denotes the applied outer pressure and i the imaginary unit. At the outlet boundary, an outgoing plane wave is set:

$$\left(-\frac{\nabla p}{\rho} \right) \cdot \mathbf{n} = \frac{i\omega}{\rho c} p$$

Results and Discussion

[Figure 2](#) visualizes the pressure field in the muffler at a frequency of 490 Hz using a boundary plot of the absolute value of the pressure and an isosurface plot of the pressure.

freq(40)=490 Hz Surface: Absolute total acoustic pressure (Pa) Isosurface: Pressure (Pa)

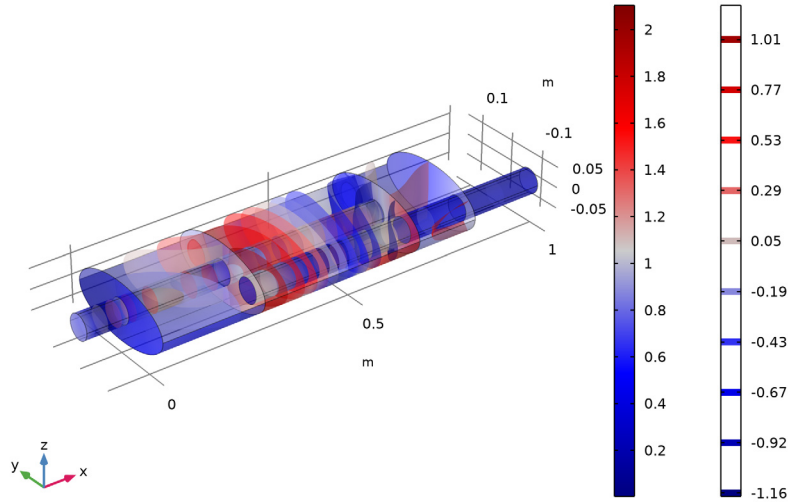

Figure 2: The solution at 490 Hz. The real value of the pressure is plotted as isosurfaces, and the absolute value of the pressure is displayed as a boundary plot on the inner walls of the muffler.

The following equation defines the transmission loss in the muffler:

$$TL = 10 \log\left(\frac{P_{in}}{P_{out}}\right)$$

Here, P_{in} and P_{out} denote the acoustic effect at the inlet and outlet, respectively. The acoustic effect is calculated using the following equations:

$$P_{in} = \int_{\partial\Omega} \frac{p_0^2}{2\rho c} dA$$

$$P_{out} = \int_{\partial\Omega} \frac{|p_c|^2}{2\rho c} dA$$

Figure 3 shows the result of a parametric frequency study. This plot reveals that the damping is better at higher frequencies, with the exception of several deep dips

throughout the frequency range. The dips correspond to the resonance frequencies for different parts of the muffler system.

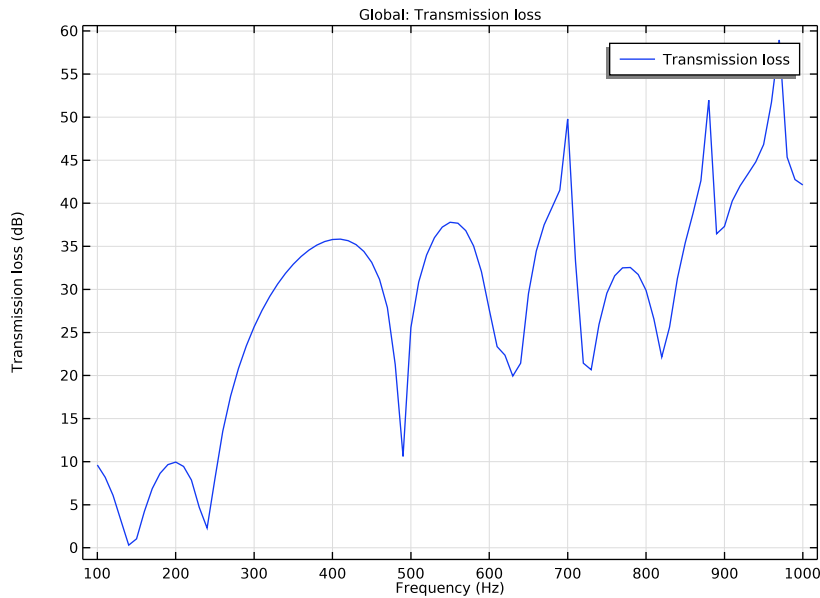



Figure 3: The damping (dB) in the muffler as a function of the frequency (Hz).

Application Library path: COMSOL_Multiphysics/Acoustics/automotive_muffler

Modeling Instructions

From the **File** menu, choose **New**.

NEW

In the **New** window, click  **Model Wizard**.

MODEL WIZARD

- 1 In the **Model Wizard** window, click  **3D**.
- 2 In the **Select Physics** tree, select **Acoustics>Pressure Acoustics>Pressure Acoustics, Frequency Domain (acpr)**.
- 3 Click **Add**.

- 4 Click  **Study**.
- 5 In the **Select Study** tree, select **General Studies>Frequency Domain**.
- 6 Click  **Done**.

GLOBAL DEFINITIONS



Parameters 1

- 1 In the **Model Builder** window, under **Global Definitions** click **Parameters 1**.
- 2 In the **Settings** window for **Parameters**, locate the **Parameters** section.
- 3 In the table, enter the following settings:

Name	Expression	Value	Description
p0	1[Pa]	1 Pa	Inlet pressure amplitude

GEOMETRY 1

Create the geometry. To simplify this step, insert a prepared geometry sequence.

- 1 In the **Geometry** toolbar, click  **Insert Sequence**.
- 2 Browse to the model's Application Libraries folder and double-click the file `automotive_muffler_geom_sequence.mph`.
- 3 In the **Geometry** toolbar, click  **Build All**.

4 Click the  **Zoom Extents** button in the **Graphics** toolbar.

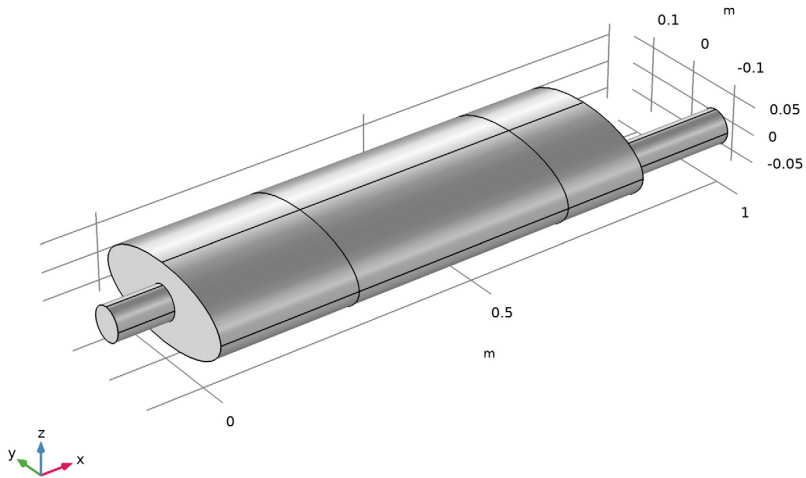

DEFINITIONS

Define integration operators for the inlet and outlet, then use these to calculate the attenuation.

Inlet

- 1 In the **Definitions** toolbar, click  **Nonlocal Couplings** and choose **Integration**.
- 2 In the **Settings** window for **Integration**, locate the **Source Selection** section.
- 3 From the **Geometric entity level** list, choose **Boundary**.

4 Select Boundary 1 only.

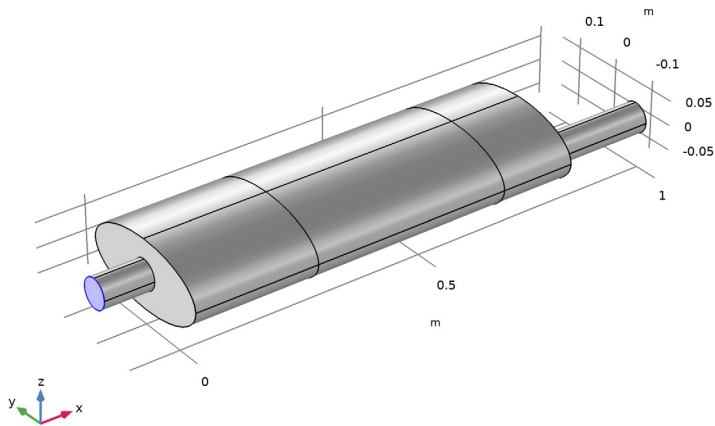

5 In the **Operator name** text field, type `intop_inlet`.

6 In the **Label** text field, type `Inlet`.

Outlet

1 In the **Definitions** toolbar, click  **Nonlocal Couplings** and choose **Integration**.

2 In the **Settings** window for **Integration**, locate the **Source Selection** section.

3 From the **Geometric entity level** list, choose **Boundary**.

4 Click the  **Wireframe Rendering** button in the **Graphics** toolbar.

5 Select Boundary 50 only.

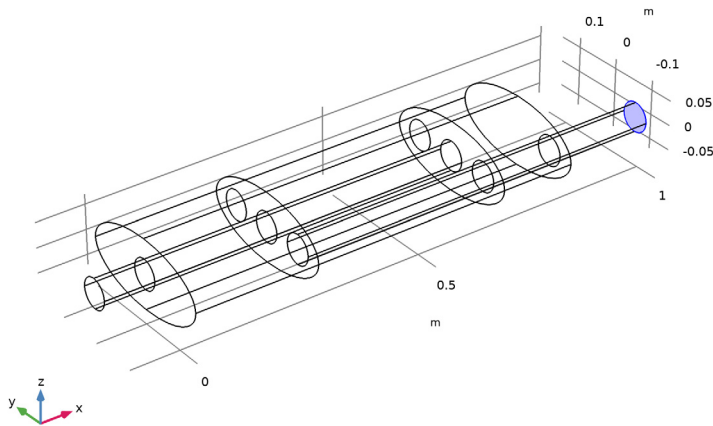

6 In the **Operator name** text field, type `intop_outlet`.

7 In the **Label** text field, type `Outlet`.

Variables 1

1 In the **Definitions** toolbar, click  **Local Variables**.

2 In the **Settings** window for **Variables**, locate the **Variables** section.

3 In the table, enter the following settings:

Name	Expression	Unit	Description
P_in	<code>intop_inlet(p0^2/(2*acpr.rho*acpr.c))</code>	W	Incoming power
P_out	<code>intop_outlet(p*conj(p)/(2*acpr.rho*acpr.c))</code>	W	Outgoing power
TL	<code>10*log10(P_in/P_out)</code>		Transmission loss

Note that you need to define the incoming power using `p0` rather than the pressure variable, `p`, because `p` is the sum of incident and reflected pressure waves.

Interior Boundaries

Create a selection to simplify setting up the interior boundary conditions.

1 In the **Definitions** toolbar, click  **Explicit**.

2 In the **Settings** window for **Explicit**, locate the **Input Entities** section.

3 From the **Geometric entity level** list, choose **Boundary**.

4 Select Boundaries 10, 11, 13, 14, 16, 20–23, 25, 26, 28, 29, 32, and 36–39 only.

To do this, click the **Paste Selection** button next to the **Selection** box, paste the text: 10, 11, 13, 14, 16, 20–23, 25, 26, 28, 29, 32, 36–39 in the text field of the dialog box that opens, and finally click **OK**.

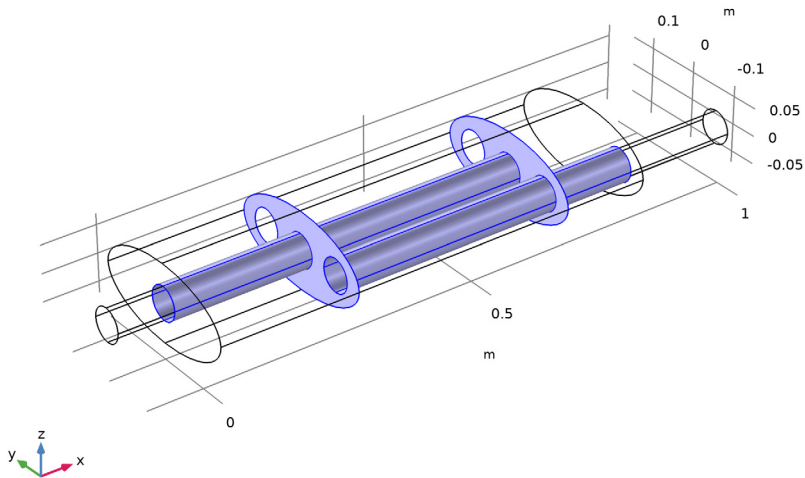

5 Click the  **Wireframe Rendering** button in the **Graphics** toolbar to return to the original state.

6 In the **Label** text field, type Interior Boundaries.

ADD MATERIAL

1 In the **Home** toolbar, click  **Add Material** to open the **Add Material** window.

2 Go to the **Add Material** window.

3 In the tree, select **Built-in>Air**.

4 Click **Add to Component** in the window toolbar.

5 In the **Home** toolbar, click  **Add Material** to close the **Add Material** window.

MATERIALS

By default, the first material you add applies for all domains. In the **Material Contents** table you can see which material properties the physics interfaces use, in this case the density and the speed of sound. Notice that these quantities are functions of the temperature and (in the case of the density) the ambient pressure.

PRESSURE ACOUSTICS, FREQUENCY DOMAIN (ACPR)

Pressure Acoustics 1

In the **Model Inputs** section you can read off and, if desired, modify the temperature and absolute pressure at which the expressions for the air density and speed of sound are calculated. For this model, use the default settings.

Plane Wave Radiation 1

- 1 In the **Model Builder** window, right-click **Pressure Acoustics, Frequency Domain (acpr)** and choose **Radiation Conditions>Plane Wave Radiation**.
- 2 Select Boundary 1 only.

Incident Pressure Field 1

- 1 In the **Physics** toolbar, click  **Attributes** and choose **Incident Pressure Field**.
- 2 In the **Settings** window for **Incident Pressure Field**, locate the **Incident Pressure Field** section.
- 3 In the p_0 text field, type p_0 .
- 4 From the c list, choose **From material**.
- 5 From the **Material** list, choose **Air (mat1)**.

Plane Wave Radiation 2

- 1 In the **Physics** toolbar, click  **Boundaries** and choose **Plane Wave Radiation**.
- 2 Select Boundary 50 only.

Note that the **Plane Wave Radiation** boundary condition is only suitable for plane waves at near right angles of incidence. For general types of waves in waveguides, use the **Port** boundary condition available with the Acoustics Module as shown in the Absorptive Muffler tutorial model.

- 3 Click the  **Transparency** button in the **Graphics** toolbar to return to the default transparency state.

Interior Sound Hard Boundary (Wall) 1

- 1 In the **Physics** toolbar, click  **Boundaries** and choose **Interior Sound Hard Boundary (Wall)**.

2 In the **Settings** window for **Interior Sound Hard Boundary (Wall)**, locate the **Boundary Selection** section.

3 From the **Selection** list, choose **Interior Boundaries**.

MESH I

Use the default physics-controlled mesh as a starting point and then modify the maximum element size so that you get 10 elements per wavelength for the highest frequency in the sweep, that is 1 kHz.

1 In the **Model Builder** window, under **Component I (comp1)** right-click **Mesh I** and choose **Build All**.

Size

1 Right-click **Component I (comp1)>Mesh I** and choose **Edit Physics-Induced Sequence**.

2 In the **Settings** window for **Size**, locate the **Element Size** section.

3 Click the **Custom** button.

4 Locate the **Element Size Parameters** section. In the **Maximum element size** text field, type $343 \text{ [m/s]} / 1 \text{ [kHz]} / 10$.

This corresponds to one 10th of the shortest wavelength.

5 Click  **Build All**.

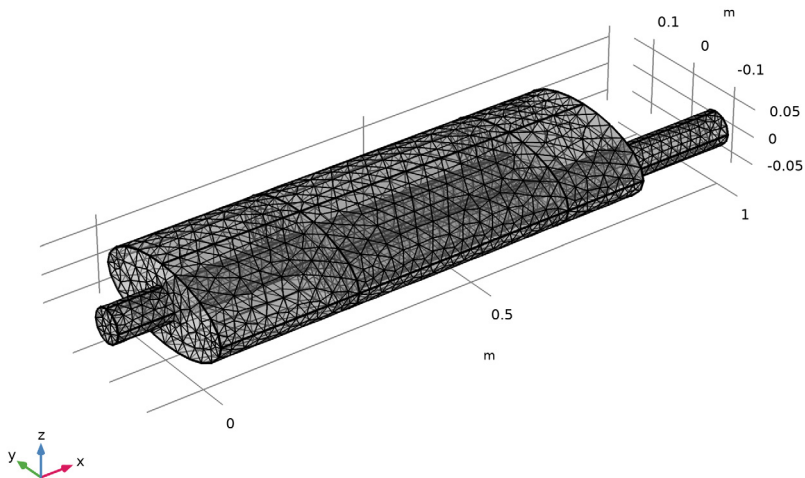

STUDY I

Step 1: Frequency Domain

- 1 In the **Model Builder** window, under **Study I** click **Step 1: Frequency Domain**.
- 2 In the **Settings** window for **Frequency Domain**, locate the **Study Settings** section.
- 3 In the **Frequencies** text field, type range (100, 10, 1000).

This computes the solution for 91 equally spaced frequencies from 100 Hz to 1000 Hz.
If you want to run a faster analysis, try the same frequency range but with a step of 100 Hz instead (to do so, type range (100, 100, 1000)).
- 4 In the **Home** toolbar, click  **Compute**.

RESULTS

Before visualizing the acoustic pressure field, add a selection to the default solution dataset that filters out the upper muffler boundaries for a better view.

Study 1/Solution 1 (sol1)

In the **Model Builder** window, expand the **Results>Datasets** node, then click **Study I / Solution 1 (sol1)**.

Selection

- 1 In the **Results** toolbar, click  **Attributes** and choose **Selection**.
- 2 In the **Settings** window for **Selection**, locate the **Geometric Entity Selection** section.
- 3 From the **Geometric entity level** list, choose **Boundary**.
- 4 Choose **All boundaries** from the **Selection** list.

- 5 Ctrl-click to highlight the six top faces of the muffler, then right-click to remove them from the selection.

Alternatively, you can click the **Paste Selection** button next to the **Selection** box and then paste the text “1–7, 9–14, 16, 17, 19–29, 31–33, 35–41, and 43–50” in the text field of the dialog box that opens before clicking **OK**.

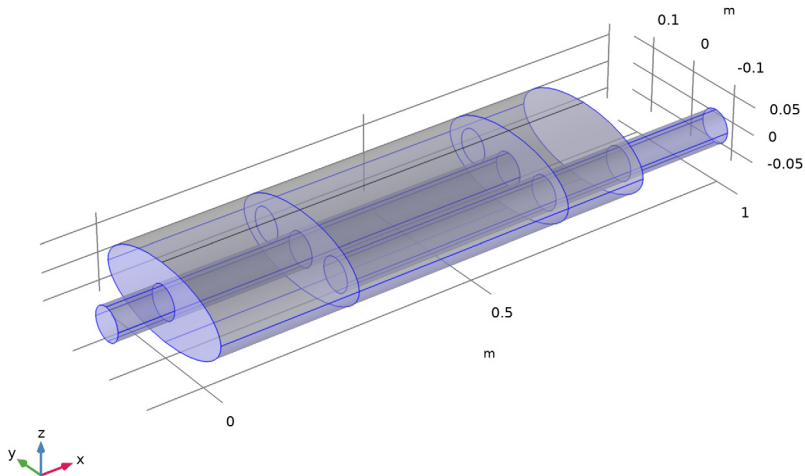

Acoustic Pressure (acpr)

Reproduce the plot in [Figure 2](#) by following these steps.

- 1 In the **Model Builder** window, click **Acoustic Pressure (acpr)**.
- 2 In the **Settings** window for **3D Plot Group**, locate the **Data** section.
- 3 From the **Parameter value (freq (Hz))** list, choose **490**.

Surface 1

- 1 In the **Model Builder** window, expand the **Acoustic Pressure (acpr)** node, then click **Surface 1**.
- 2 In the **Settings** window for **Surface**, click **Replace Expression** in the upper-right corner of the **Expression** section. From the menu, choose **Component 1 (comp1) > Pressure Acoustics, Frequency Domain > Pressure and sound pressure level > acpr.absp_t - Absolute total acoustic pressure - Pa**.
- 3 Locate the **Coloring and Style** section. Clear the **Symmetrize color range** check box.

4 In the **Acoustic Pressure (acpr)** toolbar, click  **Plot**.

Isosurface 1

- 1 In the **Model Builder** window, right-click **Acoustic Pressure (acpr)** and choose **Isosurface**.
- 2 In the **Settings** window for **Isosurface**, click **Replace Expression** in the upper-right corner of the **Expression** section. From the menu, choose **Component 1 (comp1)>Pressure Acoustics, Frequency Domain>Pressure and sound pressure level>p - Pressure - Pa**.
- 3 Locate the **Levels** section. In the **Total levels** text field, type 10.
- 4 Locate the **Coloring and Style** section. From the **Color table** list, choose **Wave**.
- 5 Select the **Symmetrize color range** check box.

What is a suitable number of isosurface levels for the isosurface plot varies with the frequency. At frequencies with low damping many of the isosurfaces tend to congregate inside the pipe.

6 In the **Acoustic Pressure (acpr)** toolbar, click  **Plot**.

7 Click the  **Zoom Extents** button in the **Graphics** toolbar.

Finally, reproduce the plot of attenuation versus frequency shown in [Figure 3](#).

ID Plot Group 4

In the **Home** toolbar, click  **Add Plot Group** and choose **ID Plot Group**.

Global 1

- 1 Right-click **ID Plot Group 4** and choose **Global**.
- 2 In the **Settings** window for **Global**, click **Replace Expression** in the upper-right corner of the **y-Axis Data** section. From the menu, choose **Component 1 (comp1)>Definitions>Variables>TL - Transmission loss**.

Transmission Loss

- 1 In the **Model Builder** window, under **Results** click **ID Plot Group 4**.
- 2 In the **Settings** window for **ID Plot Group**, type **Transmission Loss** in the **Label** text field.
- 3 Locate the **Plot Settings** section. Select the **x-axis label** check box.
- 4 In the associated text field, type **Frequency (Hz)**.
- 5 Select the **y-axis label** check box.
- 6 In the associated text field, type **Transmission loss (dB)**.

7 In the **Transmission Loss** toolbar, click  **Plot**.

Notice the deep dip in the damping around 490 Hz caused by the resonance in the second chamber. If you plot the pressure in the muffler at other dips, resonances in the other chambers appear.