



Lumped Model of a Vehicle Suspension System

Introduction

In this example, a lumped model of a vehicle suspension system having eleven degrees of freedom is analyzed. The **Mass**, **Spring**, and **Damper** nodes of the Lumped Mechanical System interface are used to model the wheels, including suspension system, as well as the seats with a passenger. The vehicle body, having three degrees of freedom, is modeled as a rigid body in the Multibody Dynamics interface. The **External Source** node of the Lumped Mechanical System interface and the **Lumped-Structure Connection** multiphysics coupling are used to connect the MBD model of the vehicle body to the lumped model of the rest of the system.

A transient analysis is performed to compute the vehicle motion and the seat vibration levels for a given road profile. The data for this model is taken from [Ref. 1](#).

Model Definition

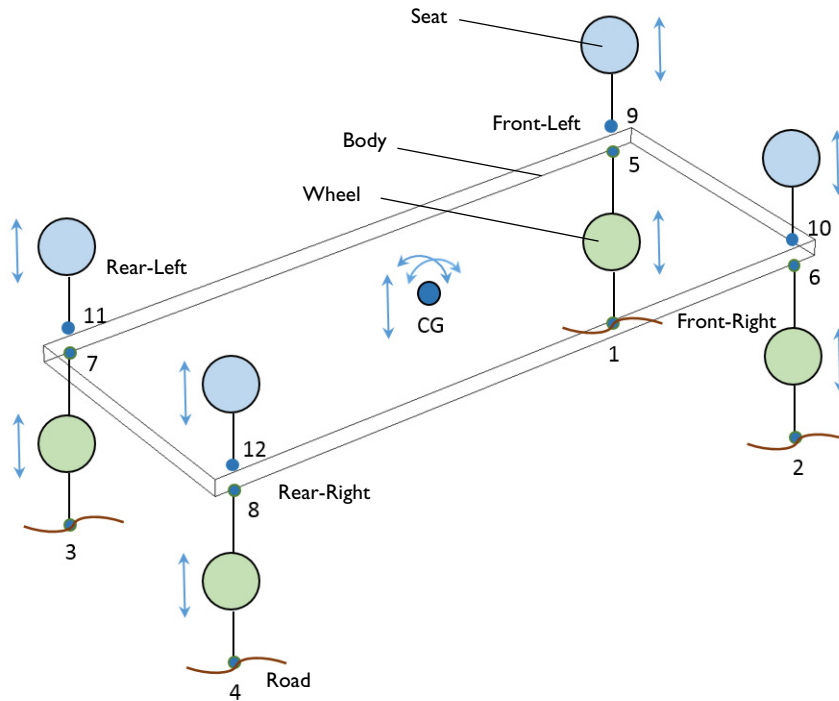

Figure 1: The lumped model of a vehicle suspension system including wheels, body, and seats. The eleven degrees of freedom of the system as well as the node numbers of the systems are also shown.

The lumped model of the vehicle suspension system is shown in Figure 1. This model has three main components:

- Wheels (4 dofs)
- Seats (4 dofs)
- Body (3 dofs)

WHEEL AND SEAT MODELING

Each wheel and seat has only one degree of freedom in the form of vertical displacement and is modeled in the Lumped Mechanical System interface. In total, there are 4 wheels and 4 seats in the full vehicle model. Both components are defined as a subsystem as shown in Figure 2.

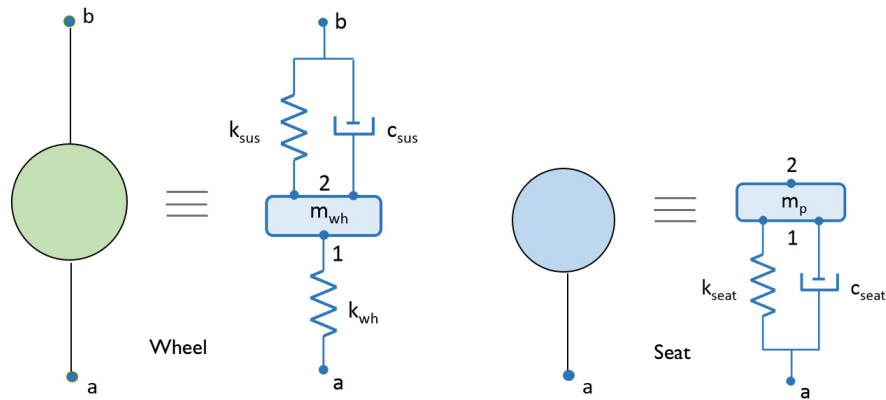

Figure 2: The lumped model of a wheel and seat of a vehicle.

The lumped model of a wheel includes the following:

- Mass and stiffness of a wheel
- Stiffness and damping of a vehicle suspension

The lumped model of a seat includes the following:

- Stiffness and damping of a seat
- Mass of a passenger

VEHICLE BODY MODELING

The vehicle body has three degrees of freedom:

- Roll
- Pitch
- Heave

As the body has rotational degrees of freedom, it is modeled using a **Rigid Domain** node in the Multibody Dynamics interface in 3D.

WHEEL-BODY AND BODY-SEAT CONNECTION

The vehicle wheels and seats are modeled in the Lumped Mechanical System interface whereas the vehicle body is modeled in the Multibody Dynamics interface. In order to connect wheel-body and body-seat, **Lumped-Structure Connection** multiphysics coupling is used. The body is modeled as an **External Source** element in the lumped system model. Through the **Lumped-Structure Connection** multiphysics coupling, the displacement obtained from the MBD vehicle body model at the connection points are used in the lumped model. Similarly, the wheel and seat reaction forces obtained from the lumped model are applied in the MBD vehicle body model.

ROAD PROFILE

The road profile is modeled as a rectangular wave function by assuming a series of bumps on the road. The bump height and width is assumed to be 4 cm and 7.5 cm, respectively. Also, the vehicle is assumed to be moving with a constant speed of 40 km/h.

The road excitation is prescribed to the bottom end of the wheels. In this model, only the left wheels of the vehicle are assumed to be moving on the uneven road.

MODEL PARAMETERS

The parameters used in the model are given in the table below:

TABLE I: MODEL PARAMETERS

DESCRIPTION	NAME	EXPRESSION
Mass of vehicle body	m_body	670 kg
Inertia around roll	I_roll	800 kg·m ²
Inertia around pitch	I_pitch	1100 kg·m ²
Mass of wheels	m_wh	30 kg
Mass of passengers	m_p	120 kg
Stiffness of wheels	k_wh	175500 N/m

TABLE 1: MODEL PARAMETERS

DESCRIPTION	NAME	EXPRESSION
Stiffness of suspension springs	k_{sus}	17500 N/m
Stiffness of seat springs	k_{seat}	1750 N/m
Viscosity of suspension dampers	c_{sus}	1460 Ns/m
Viscosity of seat dampers	c_{seat}	700 Ns/m
Wheel base	r_{wb}	1.9975 m
Track width	r_{tw}	0.8025 m

Results and Discussion

Figure 3 shows the road excitation for the front-left and rear-left wheel of the vehicle. The phase difference between the front and rear wheel excitation can be seen.

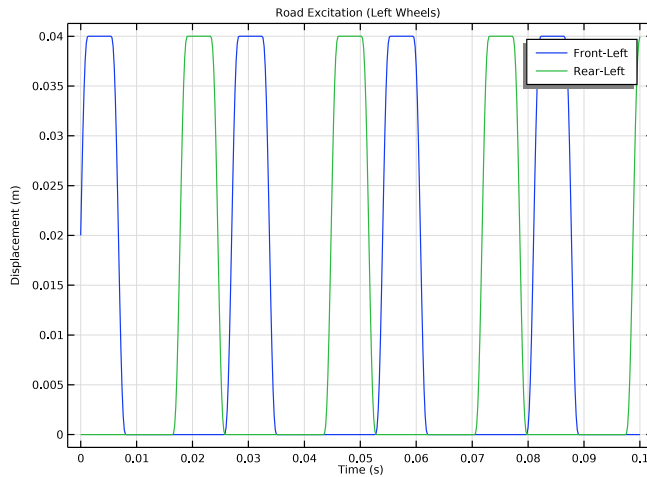

Figure 3: Road excitation for the left wheels of the vehicle.

Figure 4 shows the time history of the vehicle roll, pitch, and heave motions at the center of gravity due to the road excitation under the left wheels of the vehicle. It can be seen that the roll rotation is much larger than the pitch rotation for the given road excitation. The corresponding velocities for the roll, pitch, and heave motions can be seen in Figure 5. Two different frequencies, low and high, corresponding to the natural frequencies for the components of the system can be seen in the velocity plot.

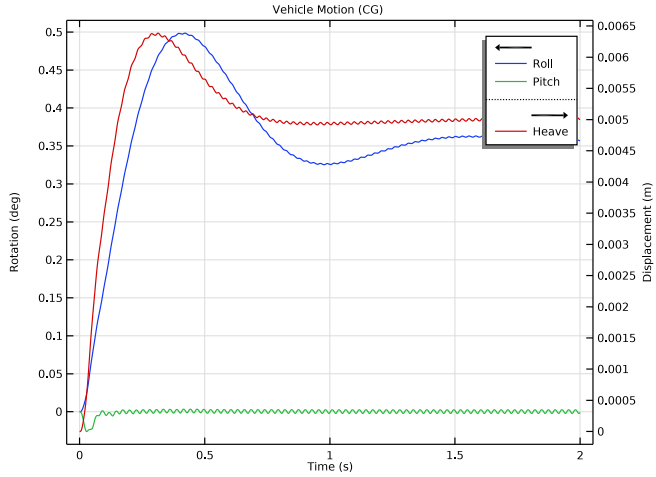

Figure 4: Vehicle roll, pitch, and heave motions at the center of gravity.

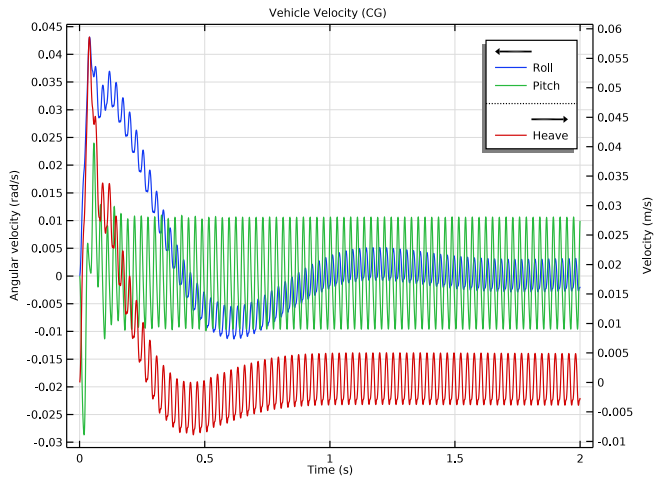

Figure 5: Vehicle velocities corresponding to the roll, pitch, and heave motions at the center of gravity.

Figure 6 and Figure 7 show the time history of displacement and acceleration at all four seat locations.

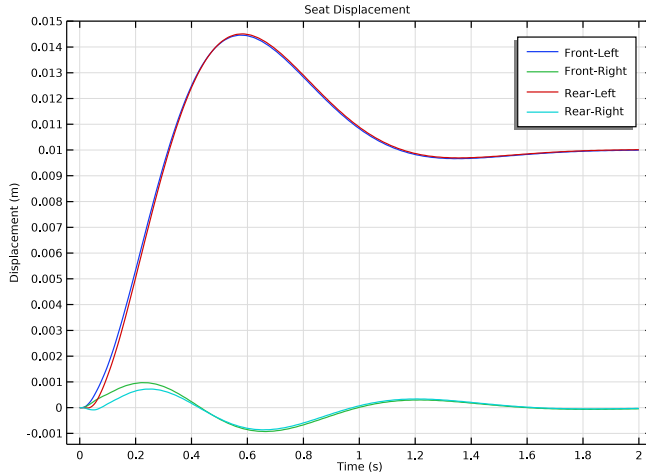

Figure 6: Time history of seat displacements.

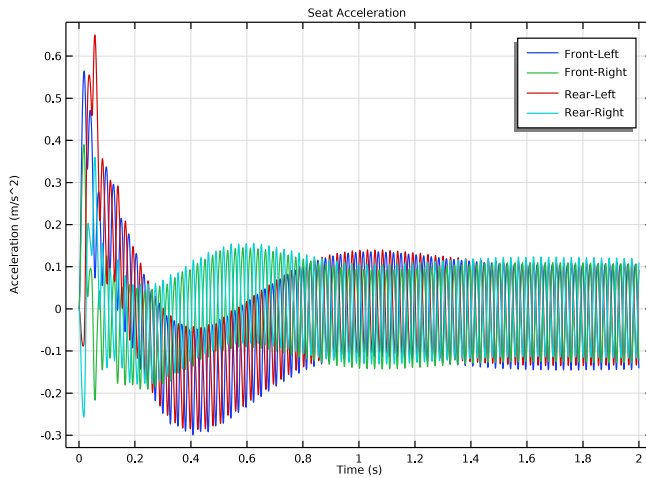

Figure 7: Time history of seat accelerations.

Figure 8 and Figure 9 show the forces in springs and damper of the front-left wheel and seat respectively. It can be seen that the force magnitude in the spring and damper of the wheel is much larger than that of a seat. The reason for this is the fact that large amount of force is absorbed by inertia of wheels and the vehicle body so that only a fraction of the force is transmitted from the wheel to the seat.

It can also be noticed that the forces in the wheel has a frequency of vibration which is the same as the excitation frequency, whereas the forces in the seat has a much lower frequency of vibration.

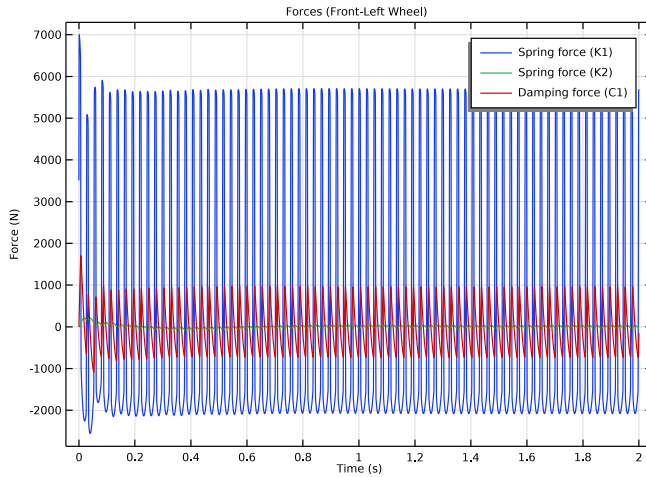

Figure 8: Forces in the springs and damper of the front-left wheel.

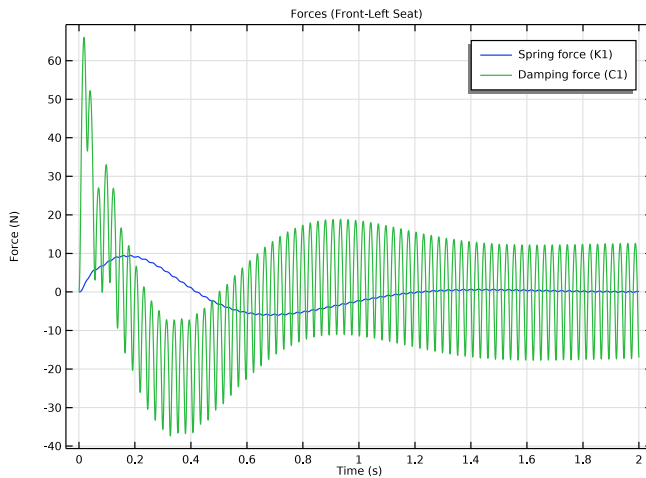

Figure 9: Forces in the spring and damper of the front-left seat.

Notes About the COMSOL Implementation

- **Fixed Node** is the default node of the **Lumped Mechanical System** interface. It can however be disabled if none of the nodes of the system is fixed.
- To re-use the lumped model definition of a wheel and seat of a vehicle, use a **Subsystem Definition** node to define the component once. Then, use **Subsystem Instance** nodes multiple times to create more than one instance of the wheels and seats.
- The **Lumped-Structure Connection** multiphysics coupling and **External Source** node can be used to connect a distributed model of a component to the lumped model of the system.
- To restrict the number of degrees of freedom of the vehicle body to be only three, the **Prescribed Displacement/Rotation** subnode of **Rigid Domain** node is used.
- To enter the lumped mass and inertia values of a vehicle body, the **Mass and Moment of Inertia** subnode of **Rigid Domain** node is used.

Reference

1. S.H. Zareh and M. Abbasi, “Semi-active vibration control of an eleven degrees of freedom suspension system using neuro inverse model of magnetorheological dampers,” *Journal of Mechanical Science and Technology*, vol. 26, no. 8, pp. 2459–2467, 2012.

Application Library path: Multibody_Dynamics_Module/
Automotive_and_Aerospace/lumped_vehicle_suspension_system

Modeling Instructions

From the **File** menu, choose **New**.

NEW



In the **New** window, click  **Model Wizard**.

MODEL WIZARD

1 In the **Model Wizard** window, click  **3D**.

2 In the **Select Physics** tree, select **Structural Mechanics>Lumped Mechanical System (lms)**.

3 Click **Add**.

- 4 In the **Select Physics** tree, select **Structural Mechanics>Multibody Dynamics (mbd)**.
- 5 Click **Add**.
- 6 Click  **Study**.
- 7 In the **Select Study** tree, select **General Studies>Time Dependent**.
- 8 Click  **Done**.

GLOBAL DEFINITIONS

Parameters 1

- 1 In the **Model Builder** window, under **Global Definitions** click **Parameters 1**.
- 2 In the **Settings** window for **Parameters**, locate the **Parameters** section.
- 3 Click  **Load from File**.
- 4 Browse to the model's Application Libraries folder and double-click the file `lumped_vehicle_suspension_system_parameters.txt`.

Use a **Waveform** function to define the road profile.

Waveform 1 (wv1)

- 1 In the **Home** toolbar, click  **Functions** and choose **Global>Waveform**.
- 2 In the **Settings** window for **Waveform**, locate the **Parameters** section.
- 3 From the **Type** list, choose **Square**.
- 4 In the **Size of transition zone** text field, type $tb/10$.
- 5 In the **Duty cycle** text field, type 0.25 .
- 6 In the **Angular frequency** text field, type $2\pi/tb$.
- 7 In the **Amplitude** text field, type $hb/2$.

Waveform 2 (wv2)

- 1 Right-click **Waveform 1 (wv1)** and choose **Duplicate**.
- 2 In the **Settings** window for **Waveform**, locate the **Parameters** section.
- 3 In the **Phase** text field, type $-2\pi/tb\cdot td$.

Create the geometry of the vehicle body and define its connection points for the wheels and seats.

GEOMETRY 1

Block 1 (blk1)

- 1 In the **Geometry** toolbar, click  **Block**.

- 2 In the **Settings** window for **Block**, locate the **Size and Shape** section.
- 3 In the **Width** text field, type $2*r_wb$.
- 4 In the **Depth** text field, type $2*r_tw$.
- 5 In the **Height** text field, type $r_wb/20$.
- 6 Locate the **Position** section. From the **Base** list, choose **Center**.
- 7 Click  **Build All Objects**.

LUMPED MECHANICAL SYSTEM (LMS)

Fixed Node 1 (fix1)

In the **Model Builder** window, under **Component 1 (comp1)>Lumped Mechanical System (lms)** right-click **Fixed Node 1 (fix1)** and choose **Disable**.

Define the lumped model of a wheel and seat using **Subsystem Definition** node.

Subsystem Definition: Wheel

- 1 In the **Model Builder** window, right-click **Lumped Mechanical System (lms)** and choose **Subsystem Definition**.
- 2 In the **Settings** window for **Subsystem Definition**, type **Subsystem Definition: Wheel** in the **Label** text field.

Spring 1 (K1)

- 1 In the **Physics** toolbar, click  **Global** and choose **Spring**.
- 2 In the **Settings** window for **Spring**, locate the **Node Connections** section.
- 3 In the table, enter the following settings:

Label	Node names
p1	a
p2	1

- 4 Locate the **Component Parameters** section. In the k text field, type k_wh .

Mass 1 (M1)

- 1 In the **Physics** toolbar, click  **Global** and choose **Mass**.
- 2 In the **Settings** window for **Mass**, locate the **Node Connections** section.
- 3 In the table, enter the following settings:

Label	Node names
p1	1

4 Locate the **Component Parameters** section. In the m text field, type m_wh .

Spring 2 (K2)

1 In the **Physics** toolbar, click  **Global** and choose **Spring**.

2 In the **Settings** window for **Spring**, locate the **Node Connections** section.

3 In the table, enter the following settings:

Label	Node names
p1	2
p2	b

4 Locate the **Component Parameters** section. In the k text field, type k_sus .

Damper 1 (C1)

1 In the **Physics** toolbar, click  **Global** and choose **Damper**.

2 In the **Settings** window for **Damper**, locate the **Node Connections** section.

3 In the table, enter the following settings:

Label	Node names
p1	2
p2	b

4 Locate the **Component Parameters** section. In the c text field, type c_sus .

Subsystem Definition: Seat

1 In the **Physics** toolbar, click  **Global** and choose **Subsystem Definition**.

2 In the **Settings** window for **Subsystem Definition**, type Subsystem Definition: Seat in the **Label** text field.

Delete the second row of the table.

Spring 1 (K1)

1 In the **Physics** toolbar, click  **Global** and choose **Spring**.

2 In the **Settings** window for **Spring**, locate the **Node Connections** section.

3 In the table, enter the following settings:

Label	Node names
p1	a
p2	1

4 Locate the **Component Parameters** section. In the k text field, type k_{seat} .

Damper 1 (C1)

1 In the **Physics** toolbar, click  **Global** and choose **Damper**.

2 In the **Settings** window for **Damper**, locate the **Node Connections** section.

3 In the table, enter the following settings:

Label	Node names
p1	a
p2	1

4 Locate the **Component Parameters** section. In the c text field, type c_{seat} .

Mass 1 (M1)

1 In the **Physics** toolbar, click  **Global** and choose **Mass**.

2 In the **Settings** window for **Mass**, locate the **Node Connections** section.

3 In the table, enter the following settings:

Label	Node names
p1	1

4 Locate the **Component Parameters** section. In the m text field, type m_p .

Free Node 1 (fr1)

1 In the **Physics** toolbar, click  **Global** and choose **Free Node**.

2 In the **Settings** window for **Free Node**, locate the **Node Connections** section.

3 In the table, enter the following settings:

Label	Node name
p1	2

Now define the road excitation for all four wheels of the vehicle.

Displacement Node: Front-Left

1 In the **Physics** toolbar, click  **Global** and choose **Displacement Node**.

2 In the **Settings** window for **Displacement Node**, type Displacement Node: Front-Left in the **Label** text field.

3 Locate the **Terminal Parameters** section. In the u_{p10} text field, type $hb/2+vw1(t[1/s])$.

Displacement Node: Front-Right

- 1 In the **Physics** toolbar, click  **Global** and choose **Displacement Node**.
- 2 In the **Settings** window for **Displacement Node**, type Displacement Node: Front-Right in the **Label** text field.
- 3 Locate the **Terminal Parameters** section. In the u_{p10} text field, type 0[mm].

Displacement Node: Rear-Left

- 1 In the **Physics** toolbar, click  **Global** and choose **Displacement Node**.
- 2 In the **Settings** window for **Displacement Node**, type Displacement Node: Rear-Left in the **Label** text field.
- 3 Locate the **Terminal Parameters** section. In the u_{p10} text field, type $hb/2+vw2(t[1/s])$.

Displacement Node: Rear-Right

- 1 In the **Physics** toolbar, click  **Global** and choose **Displacement Node**.
- 2 In the **Settings** window for **Displacement Node**, type Displacement Node: Rear-Right in the **Label** text field.
- 3 Locate the **Terminal Parameters** section. In the u_{p10} text field, type 0[mm].

Subsystem Instance X1: Front-Left Wheel

- 1 In the **Physics** toolbar, click  **Global** and choose **Subsystem Instance**.
- 2 In the **Settings** window for **Subsystem Instance**, type Subsystem Instance X1: Front-Left Wheel in the **Label** text field.
- 3 Locate the **Node Connections** section. From the **Name of subsystem link** list, choose **Subsystem Definition: Wheel (sub I)**.
- 4 In the table, enter the following settings:

Local node names	Node names
a	1
b	5

Subsystem Instances

Duplicate the node above and create more wheels using the information given in the table below:

Label	a	b
Subsystem Instance X2: Front-Right Wheel	2	6
Subsystem Instance X3: Rear-Left Wheel	3	7
Subsystem Instance X4: Rear-Right Wheel	4	8

Having defined the wheels, now define the vehicle body using an External Source node. The vehicle body has three degrees of freedom and is therefore defined in the **Multibody Dynamics** interface.

External Source E1: Front-Left

- 1 In the **Physics** toolbar, click  **Global** and choose **External Source**.
- 2 In the **Settings** window for **External Source**, type External Source E1: Front-Left in the **Label** text field.
- 3 Locate the **Node Connections** section. In the table, enter the following settings:

Label	Node names
p1	5
p2	9

- 4 Locate the **Component Parameters** section. From the **Input displacement** list, choose **From multiphysics coupling**.
- 5 Locate the **Results** section. Find the **Add the following to default results** subsection. Clear the **Force** check box.
- 6 Clear the **Displacement** check box.

External Sources

Duplicate the node above and create more external sources using the information given in the table below:

Label	p1	p2
External Source E2: Front-Right	6	10
External Source E3: Rear-Left	7	11
External Source E4: Rear-Right	8	12

Next, define the seats mounted on the body.

Subsystem Instance X5: Front-Left Seat

- 1 In the **Physics** toolbar, click  **Global** and choose **Subsystem Instance**.
- 2 In the **Settings** window for **Subsystem Instance**, type Subsystem Instance X5: Front-Left Seat in the **Label** text field.
- 3 Locate the **Node Connections** section. From the **Name of subsystem link** list, choose **Subsystem Definition: Seat (sub2)**.

4 In the table, enter the following settings:

Local node names	Node names
a	9

Subsystem Instances

Duplicate the node above and create more seats using the information given in the table below:

Label	a
Subsystem Instance X6: Front-Right Seat	10
Subsystem Instance X7: Rear-Left Seat	11
Subsystem Instance X8: Rear-Right Seat	12

Now define the vehicle body using a **Rigid Domain** node and apply wheel and seat reaction forces.

MULTIBODY DYNAMICS (MBD)

In the **Model Builder** window, under **Component 1 (comp1)** click **Multibody Dynamics (mbd)**.

Rigid Domain 1

- 1 In the **Physics** toolbar, click  **Domains** and choose **Rigid Domain**.
- 2 Select Domain 1 only.
- 3 In the **Settings** window for **Rigid Domain**, locate the **Density** section.
- 4 From the ρ list, choose **User defined**. Locate the **Center of Rotation** section. From the list, choose **User defined**.

Mass and Moment of Inertia 1

- 1 In the **Physics** toolbar, click  **Attributes** and choose **Mass and Moment of Inertia**.
- 2 In the **Settings** window for **Mass and Moment of Inertia**, locate the **Mass and Moment of Inertia** section.
- 3 In the m text field, type m_body .
- 4 From the list, choose **Diagonal**.
- 5 In the **I** table, enter the following settings:

I_roll	0	0
0	I_pitch	0
0	0	0

Rigid Domain 1



In the **Model Builder** window, click **Rigid Domain 1**.

Prescribed Displacement/Rotation 1



- 1 In the **Physics** toolbar, click  **Attributes** and choose **Prescribed Displacement/Rotation**.
- 2 In the **Settings** window for **Prescribed Displacement/Rotation**, locate the **Prescribed Displacement at Center of Rotation** section.
- 3 Select the **Prescribed in x direction** check box.
- 4 Select the **Prescribed in y direction** check box.
- 5 Locate the **Prescribed Rotation** section. From the **By** list, choose **Constrained rotation**.
- 6 Select the **Constrain rotation around z-axis** check box.

MULTIPHYSICS

Lumped-Structure Connection: Front-Left

- 1 In the **Physics** toolbar, click  **Multiphysics Couplings** and choose **Global>Lumped-Structure Connection**.
- 2 In the **Settings** window for **Lumped-Structure Connection**, type Lumped-Structure Connection: Front-Left in the **Label** text field.
- 3 Select Point 7 only.
- 4 Locate the **Point Selection, Port-2** section. Select the  **Activate Selection** toggle button.
- 5 Select Point 8 only.

Lumped-Structure Connection: Front-Right

- 1 In the **Physics** toolbar, click  **Multiphysics Couplings** and choose **Global>Lumped-Structure Connection**.
- 2 In the **Settings** window for **Lumped-Structure Connection**, type Lumped-Structure Connection: Front-Right in the **Label** text field.
- 3 Select Point 5 only.
- 4 Locate the **Point Selection, Port-2** section. Select the  **Activate Selection** toggle button.
- 5 Select Point 6 only.
- 6 Locate the **Connection Settings** section. From the list, choose **External Source E2: Front-Right**.

Lumped-Structure Connection: Rear-Left

- 1 In the **Physics** toolbar, click  **Multiphysics Couplings** and choose **Global>Lumped-Structure Connection**.
- 2 In the **Settings** window for **Lumped-Structure Connection**, type Lumped-Structure Connection: Rear-Left in the **Label** text field.
- 3 Select Point 3 only.
- 4 Locate the **Point Selection, Port-2** section. Select the **Activate Selection** toggle button.
- 5 Select Point 4 only.
- 6 Locate the **Connection Settings** section. From the list, choose **External Source E3: Rear-Left**.

Lumped-Structure Connection: Rear-Right

- 1 In the **Physics** toolbar, click  **Multiphysics Couplings** and choose **Global>Lumped-Structure Connection**.
- 2 In the **Settings** window for **Lumped-Structure Connection**, type Lumped-Structure Connection: Rear-Right in the **Label** text field.
- 3 Select Point 1 only.
- 4 Locate the **Point Selection, Port-2** section. Select the **Activate Selection** toggle button.
- 5 Select Point 2 only.
- 6 Locate the **Connection Settings** section. From the list, choose **External Source E4: Rear-Right**.

STUDY I

Step 1: Time Dependent

- 1 In the **Model Builder** window, under **Study I** click **Step 1: Time Dependent**.
- 2 In the **Settings** window for **Time Dependent**, locate the **Study Settings** section.
- 3 In the **Output times** text field, type range (0,0.0002,2).

Solution 1 (sol1)

- 1 In the **Study** toolbar, click  **Show Default Solver**.
- 2 In the **Model Builder** window, expand the **Solution I (sol1)** node.
- 3 In the **Model Builder** window, expand the **Study I>Solver Configurations>Solution I (sol1)>Time-Dependent Solver I** node.

- 4 Right-click **Time-Dependent Solver I** and choose **Fully Coupled**.
- 5 In the **Settings** window for **Fully Coupled**, click to expand the **Method and Termination** section.
- 6 From the **Jacobian update** list, choose **On every iteration**.
- 7 In the **Maximum number of iterations** text field, type 15.
- 8 In the **Study** toolbar, click  **Compute**.

Follow the instructions to plot the road excitation as shown in [Figure 3](#).

RESULTS

Road Excitation (Left Wheels)

- 1 In the **Home** toolbar, click  **Add Plot Group** and choose **ID Plot Group**.
- 2 In the **Settings** window for **ID Plot Group**, type **Road Excitation (Left Wheels)** in the **Label** text field.
- 3 Click to expand the **Title** section. From the **Title type** list, choose **Label**.
- 4 Locate the **Data** section. From the **Time selection** list, choose **Interpolated**.
- 5 In the **Times (s)** text field, type **range(0,0.0002,0.1)**.



Global I

- 1 Right-click **Road Excitation (Left Wheels)** and choose **Global**.
- 2 In the **Settings** window for **Global**, click **Replace Expression** in the upper-right corner of the **y-Axis Data** section. From the menu, choose **Component I (comp1)>Lumped Mechanical System>Node displacements>lms.u_1 - Displacement at node 1 - m**.
- 3 Click **Add Expression** in the upper-right corner of the **y-Axis Data** section. From the menu, choose **Component I (comp1)>Lumped Mechanical System>Node displacements>lms.u_3 - Displacement at node 3 - m**.
- 4 Locate the **y-Axis Data** section. In the table, enter the following settings:

Expression	Unit	Description
lms.u_1	m	Front-Left
lms.u_3	m	Rear-Left

Road Excitation (Left Wheels)

- 1 In the **Model Builder** window, click **Road Excitation (Left Wheels)**.
- 2 In the **Settings** window for **ID Plot Group**, locate the **Plot Settings** section.
- 3 Select the **y-axis label** check box.

- 4 In the associated text field, type Displacement (m).
- 5 In the **Road Excitation (Left Wheels)** toolbar, click  **Plot**.
- 6 Click the  **Zoom Extents** button in the **Graphics** toolbar.

Follow the instructions below to plot the vehicle motion and velocity as shown in [Figure 4](#) and [Figure 5](#) respectively.

Vehicle Motion (CG)

- 1 In the **Home** toolbar, click  **Add Plot Group** and choose **ID Plot Group**.
- 2 In the **Settings** window for **ID Plot Group**, type Vehicle Motion (CG) in the **Label** text field.
- 3 Locate the **Title** section. From the **Title type** list, choose **Label**.
- 4 Locate the **Plot Settings** section. Select the **Two y-axes** check box.

Global 1

- 1 Right-click **Vehicle Motion (CG)** and choose **Global**.
- 2 In the **Settings** window for **Global**, click **Replace Expression** in the upper-right corner of the **y-Axis Data** section. From the menu, choose **Component 1 (comp1)>Multibody Dynamics>Rigid domains>Rigid Domain 1>Rigid body rotation (spatial frame) - rad>mbd.rd1.thx - Rigid body rotation, x component**.
- 3 Click **Add Expression** in the upper-right corner of the **y-Axis Data** section. From the menu, choose **Component 1 (comp1)>Multibody Dynamics>Rigid domains>Rigid Domain 1>Rigid body rotation (spatial frame) - rad>mbd.rd1.thy - Rigid body rotation, y component**.
- 4 Locate the **y-Axis Data** section. In the table, enter the following settings:

Expression	Unit	Description
mbd.rd1.thx	deg	Roll
mbd.rd1.thy	deg	Pitch

Global 2



- 1 In the **Model Builder** window, right-click **Vehicle Motion (CG)** and choose **Global**.
- 2 In the **Settings** window for **Global**, click **Replace Expression** in the upper-right corner of the **y-Axis Data** section. From the menu, choose **Component 1 (comp1)>Multibody Dynamics>Rigid domains>Rigid Domain 1>Rigid body displacement (spatial frame) - m>mbd.rd1.w - Rigid body displacement, z component**.

3 Locate the **y-Axis Data** section. In the table, enter the following settings:

Expression	Unit	Description
mbd.rd1.w	m	Heave

4 Locate the **y-Axis** section. Select the **Plot on secondary y-axis** check box.

Vehicle Motion (CG)

- 1 In the **Model Builder** window, click **Vehicle Motion (CG)**.
- 2 In the **Settings** window for **ID Plot Group**, locate the **Plot Settings** section.
- 3 Select the **y-axis label** check box.
- 4 In the associated text field, type **Rotation (deg)**.
- 5 Select the **Secondary y-axis label** check box.
- 6 In the associated text field, type **Displacement (m)**.
- 7 In the **Vehicle Motion (CG)** toolbar, click  **Plot**.
- 8 Click the  **Zoom Extents** button in the **Graphics** toolbar.

Vehicle Velocity (CG)

- 1 Right-click **Vehicle Motion (CG)** and choose **Duplicate**.
- 2 In the **Settings** window for **ID Plot Group**, type **Vehicle Velocity (CG)** in the **Label** text field.
- 3 Locate the **Plot Settings** section. In the **y-axis label** text field, type **Angular velocity (rad/s)**.
- 4 In the **Secondary y-axis label** text field, type **Velocity (m/s)**.

Global 1

- 1 In the **Model Builder** window, expand the **Vehicle Velocity (CG)** node, then click **Global 1**.
- 2 In the **Settings** window for **Global**, locate the **y-Axis Data** section.
- 3 In the table, enter the following settings:

Expression	Unit	Description
mbd.rd1.th_tx	rad/s	Roll
mbd.rd1.th_ty	rad/s	Pitch



Global 2

- 1 In the **Model Builder** window, click **Global 2**.
- 2 In the **Settings** window for **Global**, locate the **y-Axis Data** section.

3 In the table, enter the following settings:

Expression	Unit	Description
mbd.rd1.wt	m/s	Heave

Vehicle Velocity (CG)

- 1 In the **Model Builder** window, click **Vehicle Velocity (CG)**.
- 2 In the **Vehicle Velocity (CG)** toolbar, click  **Plot**.
- 3 Click the  **Zoom Extents** button in the **Graphics** toolbar.

Follow the instructions below to plot the seat displacement and acceleration as shown in [Figure 6](#) and [Figure 7](#) respectively.

Seat Displacement

- 1 In the **Home** toolbar, click  **Add Plot Group** and choose **ID Plot Group**.
- 2 In the **Settings** window for **ID Plot Group**, type Seat Displacement in the **Label** text field.
- 3 Locate the **Title** section. From the **Title type** list, choose **Label**.



Global 1

- 1 Right-click **Seat Displacement** and choose **Global**.
- 2 In the **Settings** window for **Global**, click **Replace Expression** in the upper-right corner of the **y-Axis Data** section. From the menu, choose **Component 1 (comp1)>Lumped Mechanical System>Subsystem X5>Two port components>MI>lms.X5_MI_u - Displacement (M1) - m**.
- 3 Click **Add Expression** in the upper-right corner of the **y-Axis Data** section. From the menu, choose **Component 1 (comp1)>Lumped Mechanical System>Subsystem X6>Two port components>MI>lms.X6_MI_u - Displacement (M1) - m**.
- 4 Click **Add Expression** in the upper-right corner of the **y-Axis Data** section. From the menu, choose **Component 1 (comp1)>Lumped Mechanical System>Subsystem X7>Two port components>MI>lms.X7_MI_u - Displacement (M1) - m**.
- 5 Click **Add Expression** in the upper-right corner of the **y-Axis Data** section. From the menu, choose **Component 1 (comp1)>Lumped Mechanical System>Subsystem X8>Two port components>MI>lms.X8_MI_u - Displacement (M1) - m**.

6 Locate the **y-Axis Data** section. In the table, enter the following settings:

Expression	Unit	Description
lms.X5_M1_u	m	Front-Left
lms.X6_M1_u	m	Front-Right
lms.X7_M1_u	m	Rear-Left
lms.X8_M1_u	m	Rear-Right

Seat Displacement

- 1 In the **Model Builder** window, click **Seat Displacement**.
- 2 In the **Settings** window for **ID Plot Group**, locate the **Plot Settings** section.
- 3 Select the **y-axis label** check box.
- 4 In the associated text field, type Displacement (m).
- 5 In the **Seat Displacement** toolbar, click  **Plot**.
- 6 Click the  **Zoom Extents** button in the **Graphics** toolbar.

Seat Acceleration

- 1 Right-click **Seat Displacement** and choose **Duplicate**.
- 2 In the **Settings** window for **ID Plot Group**, type Seat Acceleration in the **Label** text field.
- 3 Locate the **Plot Settings** section. In the **y-axis label** text field, type Acceleration (m/s²).

Global I

- 1 In the **Model Builder** window, expand the **Seat Acceleration** node, then click **Global I**.
- 2 In the **Settings** window for **Global**, locate the **y-Axis Data** section.
- 3 In the table, enter the following settings:

Expression	Unit	Description
d(lms.X5_M1_dudt, t)	1/s	Front-Left
d(lms.X6_M1_dudt, t)	1/s	Front-Right
d(lms.X7_M1_dudt, t)	1/s	Rear-Left
d(lms.X8_M1_dudt, t)	1/s	Rear-Right

Seat Acceleration

- 1 In the **Model Builder** window, click **Seat Acceleration**.
- 2 In the **Seat Acceleration** toolbar, click  **Plot**.

- 3 Click the  **Zoom Extents** button in the **Graphics** toolbar.

Follow the instructions below to plot the forces in the front-left wheel and the seat as shown in [Figure 8](#) and [Figure 9](#) respectively.



Forces (Front-Left Wheel)

- 1 In the **Home** toolbar, click  **Add Plot Group** and choose **ID Plot Group**.
- 2 In the **Settings** window for **ID Plot Group**, type **Forces (Front-Left Wheel)** in the **Label** text field.
- 3 Locate the **Title** section. From the **Title type** list, choose **Label**.

Global I

- 1 Right-click **Forces (Front-Left Wheel)** and choose **Global**.
- 2 In the **Settings** window for **Global**, click **Replace Expression** in the upper-right corner of the **y-Axis Data** section. From the menu, choose **Component I (comp1)>Lumped Mechanical System>Subsystem XI>Two port components>K1>Ims.XI_K1_f - Spring force (K1) - N**.
- 3 Click **Add Expression** in the upper-right corner of the **y-Axis Data** section. From the menu, choose **Component I (comp1)>Lumped Mechanical System>Subsystem XI>Two port components>K2>Ims.XI_K2_f - Spring force (K2) - N**.
- 4 Click **Add Expression** in the upper-right corner of the **y-Axis Data** section. From the menu, choose **Component I (comp1)>Lumped Mechanical System>Subsystem XI>Two port components>CI>Ims.XI_CI_f - Damping force (CI) - N**.

Forces (Front-Left Wheel)

- 1 In the **Model Builder** window, click **Forces (Front-Left Wheel)**.
- 2 In the **Settings** window for **ID Plot Group**, locate the **Plot Settings** section.
- 3 Select the **y-axis label** check box.
- 4 In the associated text field, type **Force (N)**.
- 5 In the **Forces (Front-Left Wheel)** toolbar, click  **Plot**.
- 6 Click the  **Zoom Extents** button in the **Graphics** toolbar.



Forces (Front-Left Seat)

- 1 In the **Home** toolbar, click  **Add Plot Group** and choose **ID Plot Group**.
- 2 In the **Settings** window for **ID Plot Group**, type **Forces (Front-Left Seat)** in the **Label** text field.
- 3 Locate the **Title** section. From the **Title type** list, choose **Label**.

Global I

- 1 Right-click **Forces (Front-Left Seat)** and choose **Global**.
- 2 In the **Settings** window for **Global**, click **Replace Expression** in the upper-right corner of the **y-Axis Data** section. From the menu, choose **Component I (comp1)>Lumped Mechanical System>Subsystem X5>Two port components>KI>Ims.X5_KI_f - Spring force (KI) - N**.
- 3 Click **Add Expression** in the upper-right corner of the **y-Axis Data** section. From the menu, choose **Component I (comp1)>Lumped Mechanical System>Subsystem X5>Two port components>CI>Ims.X5_CI_f - Damping force (CI) - N**.

Forces (Front-Left Seat)

- 1 In the **Model Builder** window, click **Forces (Front-Left Seat)**.
- 2 In the **Settings** window for **ID Plot Group**, locate the **Plot Settings** section.
- 3 Select the **y-axis label** check box.
- 4 In the associated text field, type Force (N).
- 5 In the **Forces (Front-Left Seat)** toolbar, click  **Plot**.
- 6 Click the  **Zoom Extents** button in the **Graphics** toolbar.

