



Convection Cooling of Circuit Boards — 3D Forced Convection

Introduction

This example models the air cooling of circuit boards populated with multiple integrated circuits (ICs), which act as heat sources. Two possible cooling scenarios are shown in [Figure 1](#): vertically aligned boards using natural convection, and horizontal boards with forced convection (fan cooling). In this case, contributions caused by the induced (forced) flow of air dominate the cooling. To achieve high accuracy, the simulation models heat transport in combination with the fluid flow.

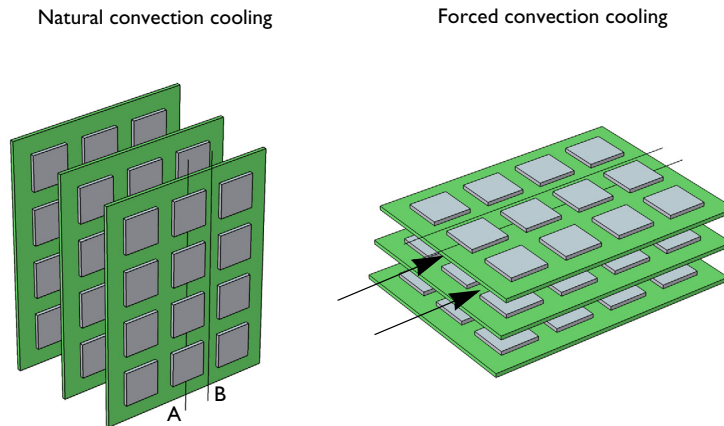

Figure 1: Stacked circuit boards with multiple in-line heat sources. Line A represents the centerline of the row of ICs, and the area between lines A-B on the board represents the symmetry.

A common technique is to describe convective heat flux with a film-resistance coefficient, h . The heat-transfer equations then become simple to solve. However, this simplification requires that the coefficient is well determined which is difficult for many systems and conditions.

An alternative way to thoroughly describe the convective heat transfer is to model the heat transfer in combination with the fluid-flow field. The results then accurately describe the heat transport and temperature changes. From such simulations it is also possible to derive accurate estimations of the film coefficients. Such models are somewhat more complex but they are useful for unusual geometries and complex flows. The following example models the heat transfer of a circuit-board assembly using the Heat Transfer Module's Conjugate

Heat Transfer predefined multiphysics coupling. The modeled scenario is based on work published by A. Ortega (Ref. 1).

FR4 circuit board material (Ref. 2) and silicon are used as the solid materials composing the circuit board system. The model treats air properties as temperature dependent.

The dimensions of the original geometry are:

- Board: length (in the flow direction) 130 mm, and the thickness is 2 mm
- ICs: length and width are both 20 mm, and thickness is 2 mm
- The distance of air between the boards is 10 mm

Model Definition

This example simulates the horizontal board with forced convection cooling as shown on the right side of the Figure 1. Due to symmetry, it is sufficient to model a unit cell, from the back side of a board to the next back side, covering the area between lines A and B. Figure 2 depicts the three-dimensional geometry.

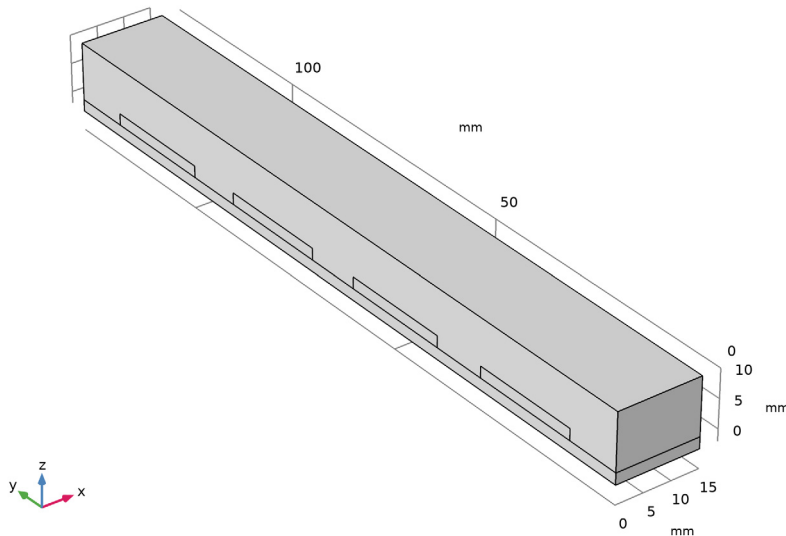

Figure 2: The modeled geometries in 3D.

The model makes use of the Conjugate Heat Transfer predefined multiphysics coupling with a stationary study to set up the simulation. The heat rate per unit volume is

1.25 MW/m³. To model forced convection, set up an inlet-velocity profile, u_y , that is uniform in the (horizontal) x direction and parabolic (similar to a fully developed laminar profile) in the (vertical) z direction. In terms of an equation this reads

$$u_y = 4\tilde{z}(1 - \tilde{z})(-u_{\max})$$

where $z = z/(10 \text{ mm})$ parameterizes the height above the board and u_{\max} , the maximal inlet speed, equals 1 m/s. At the outlet all the models use the normal flow, zero pressure boundary condition. In addition, no slip conditions at the surfaces of the board and the ICs are applied. You should also set the lateral boundaries periodic with respect to temperature, making the temperatures equal on both boundaries at every y value. Finally, the models apply continuity of temperature and heat flux at all interior boundaries.

Results and Discussion

In this example, a forced fluid inlet velocity represents the situation when a fan cools the ICs. [Figure 3](#) shows the resulting temperature distribution. The temperature rise in the ICs is approximately 20–35 K smaller compared to that for natural-convection case (see [Convection Cooling of Circuit Boards — 3D Natural Convection](#) for the model description and results). This is due to the higher average fluid velocity. In the forced

convection case, the temperature difference along the board is also less pronounced than for the natural convection.

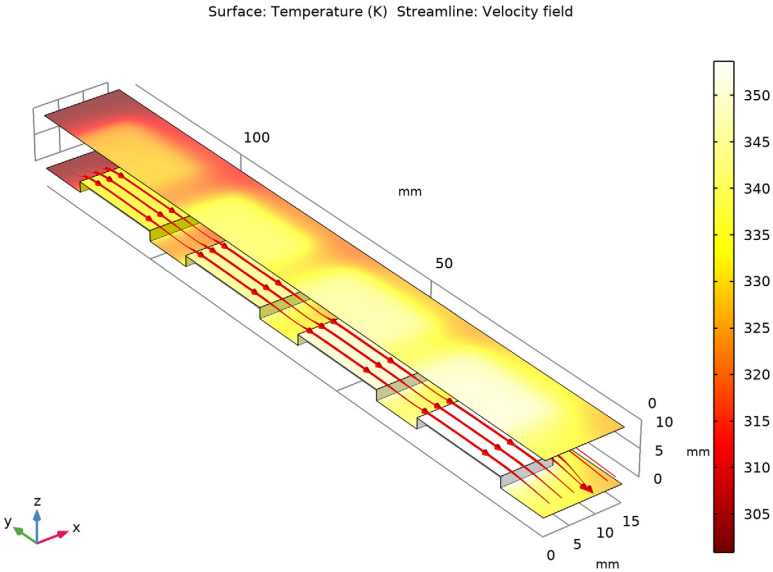

Figure 3: Temperature distribution in the case of forced convection cooling of horizontal boards.

Another interesting result, visible in [Figure 4](#), is that the channeling effect of the gap causes a reduction in the fluid's flow rate above the sources. The cooling of the ICs is therefore somewhat reduced compared to an ideal case with an even flow field.

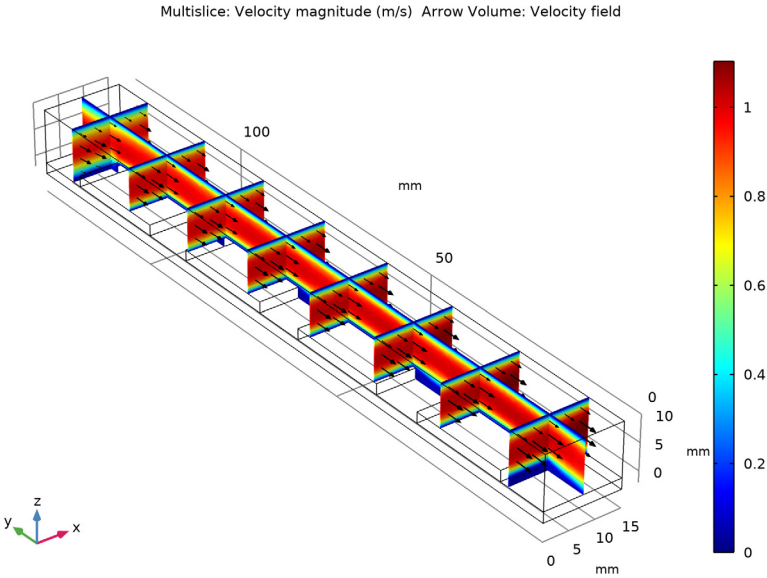

Figure 4: Velocity distribution for the case of forced convection.

The symmetry conditions used in the model indicate that the model accounts for multiple chips and boards corresponding to the boards configuration shown in [Figure 1](#). [Figure 5](#) shows the temperature profile on the stacked circuit boards and the streamlines in the surrounding air.

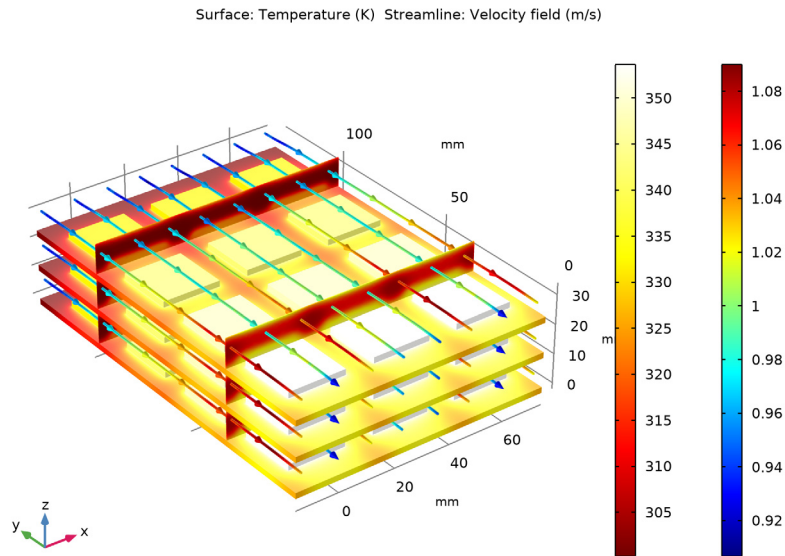

Figure 5: Temperature profile on the stacked circuit boards and streamlines.

References

1. A. Ortega, "Air Cooling of Electronics: A Personal Perspective 1981-2001," presentation material, *IEEE SMITHERM* Symposium, 2002.
2. C. Bailey, "Modeling the Effect of Temperature on Product Reliability," Proc. 19th *IEEE SMITHERM* Symposium, 2003.

Application Library path: Heat_Transfer_Module/
Power_Electronics_and_Electronic_Cooling/circuit_board_forced_3d



Modeling Instructions

From the **File** menu, choose **New**.

NEW

In the **New** window, click  **Model Wizard**.

MODEL WIZARD

- 1 In the **Model Wizard** window, click  **3D**.
- 2 In the **Select Physics** tree, select **Heat Transfer>Conjugate Heat Transfer>Laminar Flow**.
- 3 Click **Add**.
- 4 Click  **Study**.
- 5 In the **Select Study** tree, select **General Studies>Stationary**.
- 6 Click  **Done**.

GLOBAL DEFINITIONS

Parameters 1

- 1 In the **Model Builder** window, under **Global Definitions** click **Parameters 1**.
- 2 In the **Settings** window for **Parameters**, locate the **Parameters** section.
- 3 In the table, enter the following settings:

Name	Expression	Value	Description
q_source	$1[\text{W}] / (20 \times 20 \times 2[\text{mm}^3])$	1.25E6 W/m ³	Heating power per unit volume
T0	300[K]	300 K	External air temperature
patm	1[atm]	1.0133E5 Pa	Air pressure
umax	1[m/s]	1 m/s	Inlet velocity

GEOMETRY 1

- 1 In the **Model Builder** window, under **Component 1 (comp1)** click **Geometry 1**.
- 2 In the **Settings** window for **Geometry**, locate the **Units** section.
- 3 From the **Length unit** list, choose **mm**.

Block 1 (blk1)



- 1 In the **Geometry** toolbar, click  **Block**.
- 2 In the **Settings** window for **Block**, locate the **Size and Shape** section.
- 3 In the **Width** text field, type 15.
- 4 In the **Depth** text field, type 130.
- 5 In the **Height** text field, type 12.

- 6 Locate the **Position** section. In the **z** text field, type -2.
- 7 Click to expand the **Layers** section. In the table, enter the following settings:



Layer name	Thickness (mm)
Layer 1	2

- 8 In the **Geometry** toolbar, click  **Build All**.

Block 2 (blk2)

- 1 In the **Geometry** toolbar, click  **Block**.
- 2 In the **Settings** window for **Block**, locate the **Size and Shape** section.
- 3 In the **Width** text field, type 10.
- 4 In the **Depth** text field, type 20.
- 5 In the **Height** text field, type 2.
- 6 Locate the **Position** section. In the **y** text field, type 10.
- 7 In the **Geometry** toolbar, click  **Build All**.



Array 1 (arr1)

- 1 In the **Geometry** toolbar, click  **Transforms** and choose **Array**.
- 2 Select the object **blk2** only.
- 3 In the **Settings** window for **Array**, locate the **Size** section.
- 4 In the **y size** text field, type 4.
- 5 Locate the **Displacement** section. In the **y** text field, type 30.
- 6 In the **Geometry** toolbar, click  **Build All**.

DEFINITIONS

Create appropriate selections to simplify the model specification.

IC

- 1 In the **Definitions** toolbar, click  **Explicit**.
- 2 In the **Settings** window for **Explicit**, type IC in the **Label** text field.
- 3 Click the  **Wireframe Rendering** button in the **Graphics** toolbar to access the domains to select.

4 Select Domains 3–6 only.

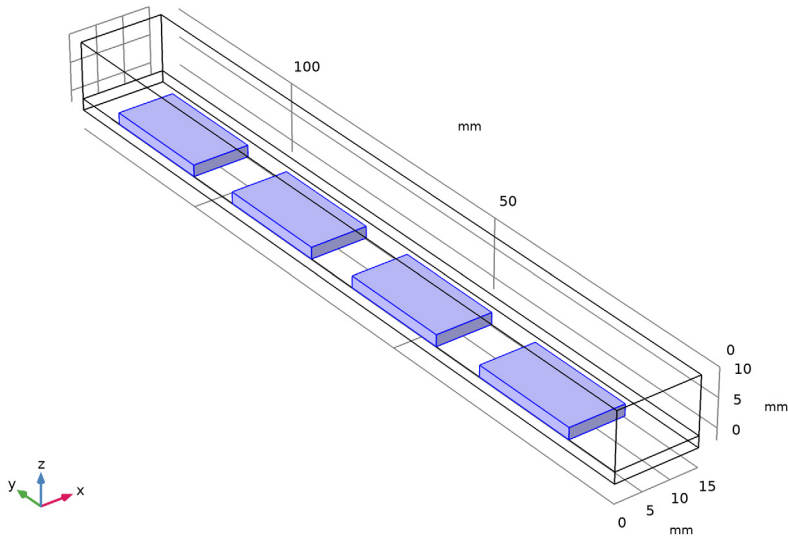



Solid Boundaries

- 1 In the **Definitions** toolbar, click  **Explicit**.
- 2 In the **Settings** window for **Explicit**, type Solid Boundaries in the **Label** text field.
- 3 Locate the **Input Entities** section. From the **Geometric entity level** list, choose **Boundary**.
- 4 Select Boundaries 6–9, 11–14, 16–19, 21–24, 26, 27, and 30–33 only.

For more convenience in selecting these boundaries, you can click the **Paste Selection** button and paste the above numbers.

ADD MATERIAL

- 1 In the **Home** toolbar, click  **Add Material** to open the **Add Material** window.
- 2 Go to the **Add Material** window.
- 3 In the tree, select **Built-in>Air**.
- 4 Click **Add to Component** in the window toolbar.
- 5 In the tree, select **Built-in>Silicon**.
- 6 Click **Add to Component** in the window toolbar.
- 7 In the tree, select **Built-in>FR4 (Circuit Board)**.

- 8 Click **Add to Component** in the window toolbar.
- 9 In the **Home** toolbar, click  **Add Material** to close the **Add Material** window.

MATERIALS

Air (mat1)

- 1 In the **Model Builder** window, under **Component 1 (comp1)>Materials** click **Air (mat1)**.
- 2 Select Domain 2 only.
- 3 In the **Settings** window for **Material**, locate the **Geometric Entity Selection** section.
- 4 Click  **Create Selection**.
- 5 In the **Create Selection** dialog box, type Air in the **Selection name** text field.
- 6 Click **OK**.

Silicon (mat2)

- 1 In the **Model Builder** window, click **Silicon (mat2)**.
- 2 In the **Settings** window for **Material**, locate the **Geometric Entity Selection** section.
- 3 From the **Selection** list, choose **IC**.

FR4 (Circuit Board) (mat3)

- 1 In the **Model Builder** window, click **FR4 (Circuit Board) (mat3)**.
- 2 Select Domain 1 only.

LAMINAR FLOW (SPF)

- 1 In the **Model Builder** window, under **Component 1 (comp1)** click **Laminar Flow (spf)**.
- 2 In the **Settings** window for **Laminar Flow**, locate the **Domain Selection** section.
- 3 From the **Selection** list, choose **Air**.

Symmetry 1

- 1 In the **Physics** toolbar, click  **Boundaries** and choose **Symmetry**.
- 2 Select Boundaries 4 and 35 only.

Open Boundary 1

- 1 In the **Physics** toolbar, click  **Boundaries** and choose **Open Boundary**.
- 2 Select Boundary 5 only.

Inlet 1

- 1 In the **Physics** toolbar, click  **Boundaries** and choose **Inlet**.
- 2 Select Boundary 29 only.

- 3 In the **Settings** window for **Inlet**, locate the **Velocity** section.
- 4 Click the **Velocity field** button.
- 5 Specify the \mathbf{u}_0 vector as

0	x
$-4e4*umax*z*(0.01-z) [1/m^2]$	y
0	z

HEAT TRANSFER IN SOLIDS AND FLUIDS (HT)

Fluid 1

- 1 In the **Model Builder** window, under **Component 1 (comp1)> Heat Transfer in Solids and Fluids (ht)** click **Fluid 1**.
- 2 In the **Settings** window for **Fluid**, locate the **Domain Selection** section.
- 3 From the **Selection** list, choose **Air**.

Initial Values 1

- 1 In the **Model Builder** window, click **Initial Values 1**.
- 2 In the **Settings** window for **Initial Values**, locate the **Initial Values** section.
- 3 In the T text field, type T_0 .

Heat Source 1

- 1 In the **Physics** toolbar, click  **Domains** and choose **Heat Source**.
- 2 In the **Settings** window for **Heat Source**, locate the **Domain Selection** section.
- 3 From the **Selection** list, choose **IC**.
- 4 Locate the **Heat Source** section. In the Q_0 text field, type q_source .

Open Boundary 1

- 1 In the **Physics** toolbar, click  **Boundaries** and choose **Open Boundary**.
- 2 Select Boundary 5 only.
- 3 In the **Settings** window for **Open Boundary**, locate the **Upstream Properties** section.
- 4 In the T_{ustr} text field, type T_0 .

Inflow 1

- 1 In the **Physics** toolbar, click  **Boundaries** and choose **Inflow**.
- 2 Select Boundary 29 only.
- 3 In the **Settings** window for **Inflow**, locate the **Upstream Properties** section.

4 In the T_{ustr} text field, type T0.

Periodic Condition 1

- 1 In the **Physics** toolbar, click  **Boundaries** and choose **Periodic Condition**.
- 2 Select Boundaries 3 and 7 only.

MESH 1

- 1 In the **Model Builder** window, under **Component 1 (comp1)** click **Mesh 1**.
- 2 In the **Settings** window for **Mesh**, locate the **Physics-Controlled Mesh** section.
- 3 From the **Element size** list, choose **Coarse**.
- 4 Click  **Build All**.

You should now see the following meshed geometry.

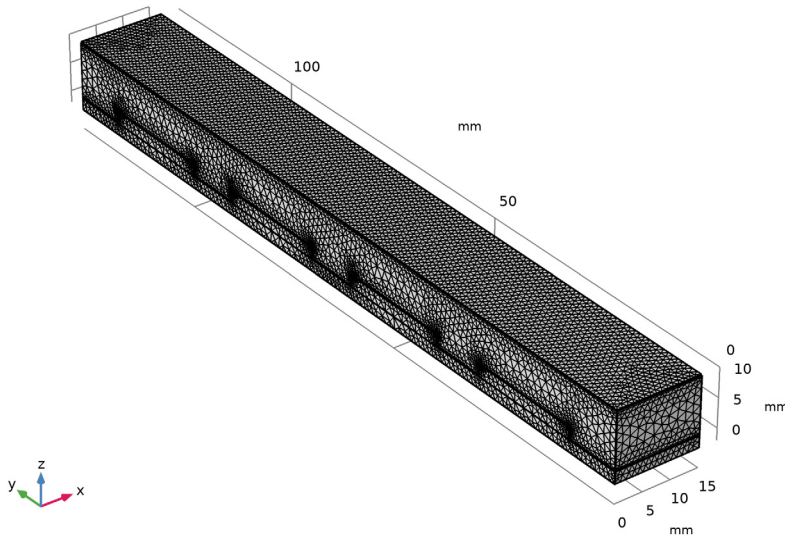

STUDY 1

The model is now ready for solving. Optionally, to avoid a warning message about an ill-conditioned preconditioner increase the factor in error estimate as follows.

Solution 1 (sol1)

- 1 In the **Study** toolbar, click  **Show Default Solver**.
- 2 In the **Model Builder** window, expand the **Solution 1 (sol1)** node.

- 3 In the **Model Builder** window, expand the **Study 1>Solver Configurations>Solution 1 (sol1)>Stationary Solver 1** node, then click **Segregated 1**.
- 4 In the **Settings** window for **Segregated**, locate the **General** section.
- 5 From the **Stabilization and acceleration** list, choose **Anderson acceleration**.
- 6 In the **Study** toolbar, click  **Compute**.



To reproduce [Figure 3](#) do as follows.

RESULTS

Temperature (ht)

- 1 In the **Settings** window for **3D Plot Group**, locate the **Data** section.
- 2 From the **Dataset** list, choose **Exterior Walls**.

Streamline 1

- 1 In the **Temperature (ht)** toolbar, click  **Streamline**.
- 2 In the **Settings** window for **Streamline**, locate the **Data** section.
- 3 From the **Dataset** list, choose **Study 1/Solution 1 (sol1)**.
- 4 Click **Replace Expression** in the upper-right corner of the **Expression** section. From the menu, choose **Component 1 (comp1)>Laminar Flow>Velocity and pressure>u,v,w - Velocity field**.
- 5 Locate the **Streamline Positioning** section. From the **Entry method** list, choose **Coordinates**.
- 6 In the **x** text field, type $1+2*\text{range}(0,6)$.
- 7 In the **y** text field, type 130.
- 8 In the **z** text field, type 1.6.
- 9 Locate the **Coloring and Style** section. Find the **Line style** subsection. From the **Type** list, choose **Tube**.
- 10 Find the **Point style** subsection. From the **Type** list, choose **Arrow**.
- 11 Find the **Line style** subsection. In the **Tube radius expression** text field, type $ht.\text{gradTmag}[m^2/K]$.
The streamlines tube radius would correspond to the magnitude of the temperature gradient.
- 12 Click to expand the **Inherit Style** section. From the **Plot** list, choose **Surface**.
- 13 In the **Temperature (ht)** toolbar, click  **Plot**.

Velocity (spf)

The third default plot shows the velocity field, the last one shows the pressure field.

To visualize the velocity field (Figure 4), follow the steps below.

Slice

- 1 In the **Model Builder** window, expand the **Velocity (spf)** node, then click **Slice**.
- 2 In the **Settings** window for **Slice**, locate the **Plane Data** section.
- 3 In the **Planes** text field, type 1.
- 4 Right-click **Slice** and choose **Delete**.
- 5 Click **Yes** to confirm.

Velocity (spf)

In the **Model Builder** window, click **Velocity (spf)**.



Multislice 1

- 1 In the **Velocity (spf)** toolbar, click  **More Plots** and choose **Multislice**.
- 2 In the **Settings** window for **Multislice**, click **Replace Expression** in the upper-right corner of the **Expression** section. From the menu, choose **Component 1 (comp1)>Laminar Flow>Velocity and pressure>spf.U - Velocity magnitude - m/s**.
- 3 Locate the **Multipane Data** section. Find the **y-planes** subsection. In the **Planes** text field, type 8.
- 4 Find the **z-planes** subsection. In the **Planes** text field, type 0.

Velocity (spf)

In the **Model Builder** window, click **Velocity (spf)**.

Arrow Volume 1

- 1 In the **Velocity (spf)** toolbar, click  **Arrow Volume**.
- 2 In the **Settings** window for **Arrow Volume**, click **Replace Expression** in the upper-right corner of the **Expression** section. From the menu, choose **Component 1 (comp1)>Laminar Flow>Velocity and pressure>u,v,w - Velocity field**.
- 3 Locate the **Arrow Positioning** section. Find the **x grid points** subsection. In the **Points** text field, type 5.
- 4 Find the **y grid points** subsection. In the **Points** text field, type 8.
- 5 Find the **z grid points** subsection. In the **Points** text field, type 5.
- 6 Locate the **Coloring and Style** section. From the **Color** list, choose **Black**.
- 7 In the **Velocity (spf)** toolbar, click  **Plot**.

To create a plot showing several layers of chips as in [Figure 5](#), follow the instructions below.

Exterior Walls

- 1 In the **Model Builder** window, expand the **Results>Datasets** node, then click **Exterior Walls**.
- 2 Select Boundaries 1–3, 6, 9, 11, 12, 14, 16, 17, 19, 21, 22, 24, 26–28, and 30–34 only.

Mirror 3D 1

In the **Results** toolbar, click  **More Datasets** and choose **Mirror 3D**.

Array 3D 1

- 1 In the **Results** toolbar, click  **More Datasets** and choose **Array 3D**.
- 2 In the **Settings** window for **Array 3D**, locate the **Data** section.
- 3 From the **Dataset** list, choose **Mirror 3D 1**.
- 4 Locate the **Array Size** section. In the **x size** text field, type 3.
- 5 In the **z size** text field, type 3.
- 6 Locate the **Displacement** section. From the **Method** list, choose **Manual**.
- 7 In the **x** text field, type 30.
- 8 In the **z** text field, type 12.

Array 3D 1, Mirror 3D 1

In the **Model Builder** window, under **Results>Datasets**, Ctrl-click to select **Mirror 3D 1** and **Array 3D 1**.

Mirror 3D 2

- 1 Right-click and choose **Duplicate**.
- 2 In the **Settings** window for **Mirror 3D**, locate the **Data** section.
- 3 From the **Dataset** list, choose **Exterior Walls**.

Array 3D 2

- 1 In the **Model Builder** window, click **Array 3D 2**.
- 2 In the **Settings** window for **Array 3D**, locate the **Data** section.
- 3 From the **Dataset** list, choose **Mirror 3D 2**.

Temperature (ht)

- 1 In the **Model Builder** window, click **Temperature (ht)**.
- 2 In the **Settings** window for **3D Plot Group**, locate the **Data** section.

- 3 From the **Dataset** list, choose **Array 3D 1**.
- 4 Locate the **Plot Settings** section. Clear the **Plot dataset edges** check box.

Surface

- 1 In the **Model Builder** window, click **Surface**.
- 2 In the **Settings** window for **Surface**, locate the **Data** section.
- 3 From the **Dataset** list, choose **Array 3D 2**.

Slice 1

- 1 In the **Model Builder** window, right-click **Temperature (ht)** and choose **Slice**.
- 2 In the **Settings** window for **Slice**, click to expand the **Title** section.
- 3 From the **Title type** list, choose **None**.
- 4 Locate the **Plane Data** section. From the **Plane** list, choose **zx-planes**.
- 5 In the **Planes** text field, type 2.
- 6 Click to expand the **Inherit Style** section. From the **Plot** list, choose **Surface**.

Streamline 1

- 1 In the **Model Builder** window, click **Streamline 1**.
- 2 In the **Settings** window for **Streamline**, locate the **Data** section.
- 3 From the **Dataset** list, choose **From parent**.
- 4 Click to expand the **Title** section. From the **Title type** list, choose **Custom**.
- 5 Find the **User** subsection. In the **Suffix** text field, type (m/s).
- 6 Locate the **Streamline Positioning** section. In the **x** text field, type range (-13, 12, 71) range (-13, 12, 71) range (-13, 12, 71).
- 7 In the **z** text field, type 6, 6, 6, 6, 6, 6, 6, 6, 18, 18, 18, 18, 18, 18, 18, 18, 30, 30, 30, 30, 30, 30, 30, 30.
- 8 Locate the **Coloring and Style** section. Find the **Line style** subsection. In the **Tube radius expression** text field, type 0.4.
- 9 Select the **Radius scale factor** check box.
- 10 In the associated text field, type 1.
- 11 Find the **Point style** subsection. Select the **Number of arrows** check box.
- 12 In the associated text field, type 150.
- 13 Locate the **Inherit Style** section. From the **Plot** list, choose **None**.

Color Expression 1

- 1 In the **Temperature (ht)** toolbar, click  **Color Expression**.

- 2 In the **Settings** window for **Color Expression**, click **Replace Expression** in the upper-right corner of the **Expression** section. From the menu, choose **Component I (comp1)> Laminar Flow>Velocity and pressure>spf.U - Velocity magnitude - m/s**.
- 3 In the **Temperature (ht)** toolbar, click  **Plot**.