



Solid Oxide Electrolyzer

Introduction

This example models a solid oxide electrolyzer cell wherein water vapor is reduced to form hydrogen gas on the cathode, and oxygen gas is evolved on the anode. The current distribution in the cell is coupled to the cathode mass transfer of hydrogen and water and momentum transport.

Model Definition

On the anode, oxygen ions are oxidized to form oxygen gas,

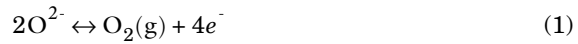

whereas on the cathode, water vapor is reduced to form hydrogen gas and oxygen ions:

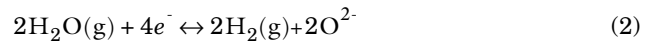

[Figure 1](#) shows the model geometry. Since the oxygen is the only gas present in the anode gas chamber, and isobaric conditions are assumed, there is no need to explicitly model the anode gas transport. Four computational domains are hence used in the model: the

cathode gas channels, the cathode gas diffusion electrode, the solid oxide electrolyte layer, and the anode gas diffusion electrode.

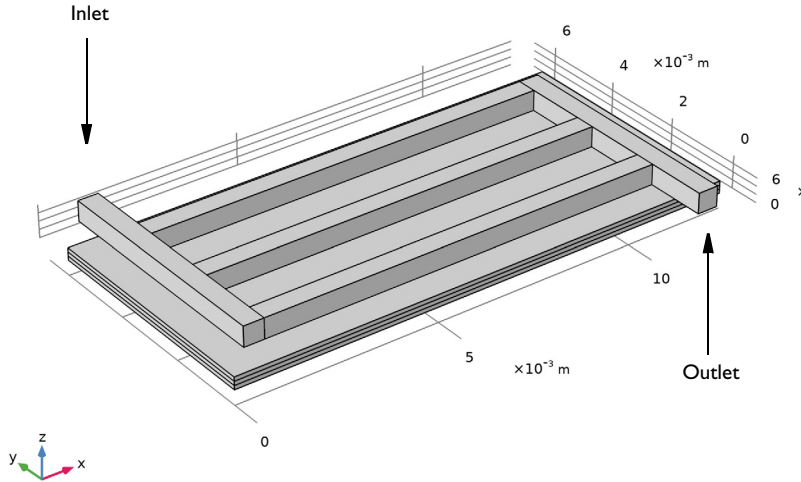

Figure 1: Model geometry. From top: Cathode gas channels, cathode gas diffusion electrode, solid oxide electrolyte layer, and anode gas diffusion layer. The positions of the inlet and outlet are indicated in the figure.

The composition of the hydrogen-water vapor mixture will change as a result of the electrochemical reactions. The mass transport of hydrogen and water vapor is modeled in the cathode gas channels and the gas diffusion electrode, coupled to the resulting (laminar) flow of the gas mixture.

The current distribution is defined assuming a constant conductivity of the solid electrolyte. The Water Electrolyzer interface is used to define the electrode reactions and the electrolyte charge transport in the porous gas diffusion electrodes and the electrolyte layer, as well as the mass transport of hydrogen and water. The momentum flow is defined in the model using the Free and Porous Media Flow interface. Brinkman equations are used for the porous gas diffusion electrodes and Navier-Stokes equations are used for the nonporous gas channels.

On the cathode side, the electrode kinetics depends on the local concentration of water and hydrogen according to the law of mass action (and Nernst equation). On the anode

side, and a uniform partial pressure of oxygen is assumed and a concentration-independent Butler-Volmer expression is hence used to define the electrode kinetics.

The properties of the cathode gas mixture, as well as the equilibrium potentials of the electrode reactions are automatically defined by the default built-in options of the Water Electrolyzer interface.

Results and Discussion

Figure 2 shows the velocity magnitude distribution in the cell. The highest velocities are located close to the inlet and outlet.

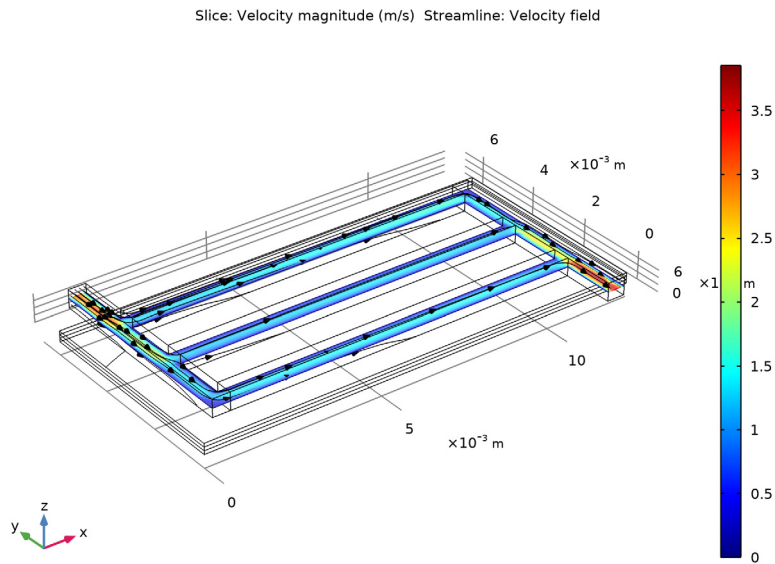

Figure 2: Velocity in the cell.

Figure 3 shows how the density and the dynamic viscosity of the gas relate to the hydrogen and water molar fractions shown in Figure 4. As the hydrogen content of the gas increases toward the outlet, the density and the viscosity both decrease.

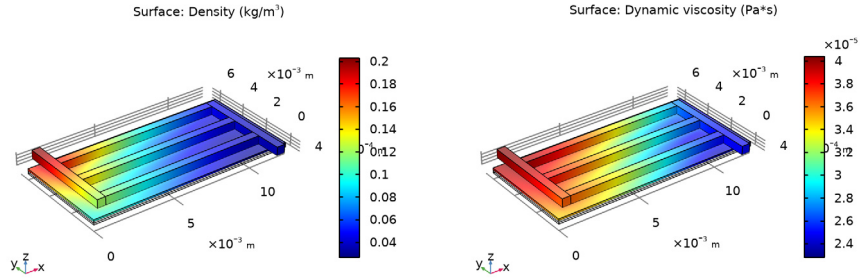

Figure 3: Density (left) and dynamic viscosity (right).

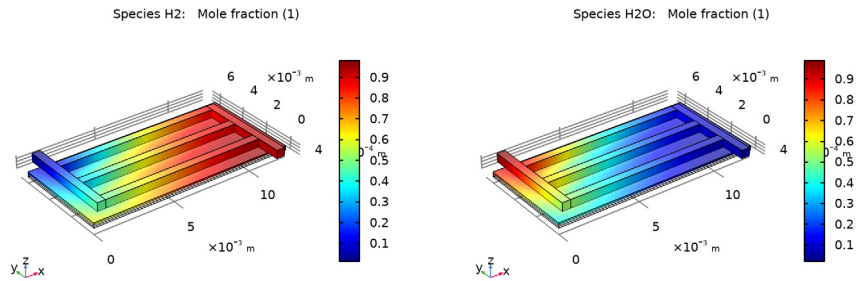

Figure 4: Hydrogen (left) and water vapor (right) molar fractions.

Figure 5 shows the molar fraction of hydrogen in the gas mixture, and the corresponding hydrogen flux streamlines. The molar fraction is close to zero at the inlet and almost 100% at the outlet.

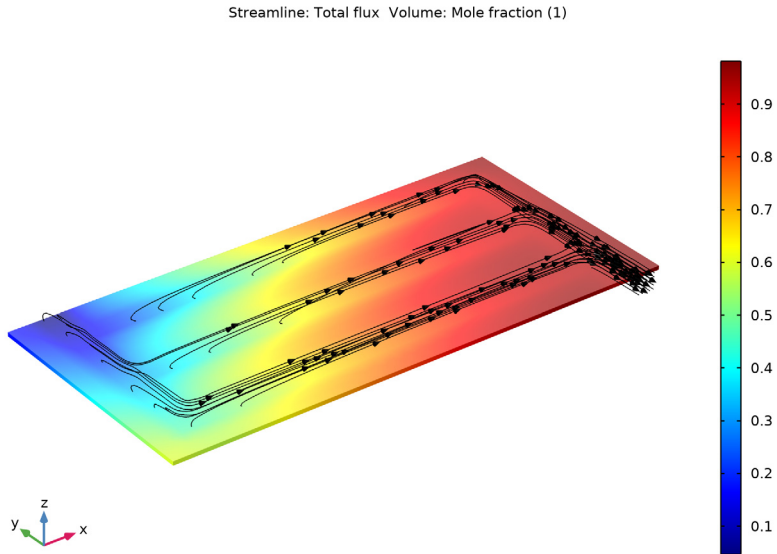

Figure 5: Hydrogen molar fraction (slice) and flux (streamlines).

Finally, Figure 6 shows the cross-sectional electrolyte current density in the middle of the electrolyte between the anode and the cathode. The current density is highest close to the inlet, where the water/hydrogen ratio is high, and decreases toward the outlet.

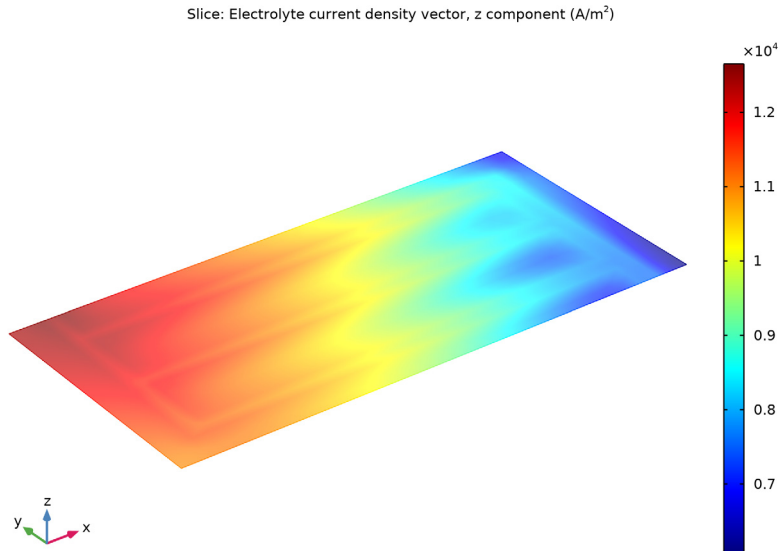

Figure 6: Electrolyte current density through electrolyte layer.

Application Library path: Fuel_Cell_and_Electrolyzer_Module/Electrolyzers/soec

Modeling Instructions



This tutorial models the current distribution in a solid oxide electrolyzer. The tutorial comprises two major parts. First, a secondary (not concentration dependent) current distribution is modeled. In the second part, mass and momentum transport are added to model a concentration-dependent current distribution of the cell, where the mixture properties of the anode gas depends on the molar fractions of water and hydrogen.

From the **File** menu, choose **New**.

NEW



In the **New** window, click  **Model Wizard**.

MODEL WIZARD

- 1 In the **Model Wizard** window, click  **3D**.
- 2 In the **Select Physics** tree, select **Electrochemistry>Water Electrolyzers>Solid Oxide (we)**.
- 3 Click **Add**.
- 4 Click  **Study**.
- 5 In the **Select Study** tree, select **Preset Studies for Selected Physics Interfaces>Stationary with Initialization**.
- 6 Click  **Done**.

GEOMETRY I

The model geometry is available as a parameterized geometry sequence in a separate MPH-file. If you want to build it from scratch, follow the instructions in the section [Appendix - Geometry Modeling Instructions](#). Otherwise load it from file using the following steps.

- 1 In the **Geometry** toolbar, click  **Insert Sequence**.
- 2 Browse to the model's Application Libraries folder and double-click the file `soec_geom_sequence.mph`.
- 3 In the **Geometry** toolbar, click  **Build All**.

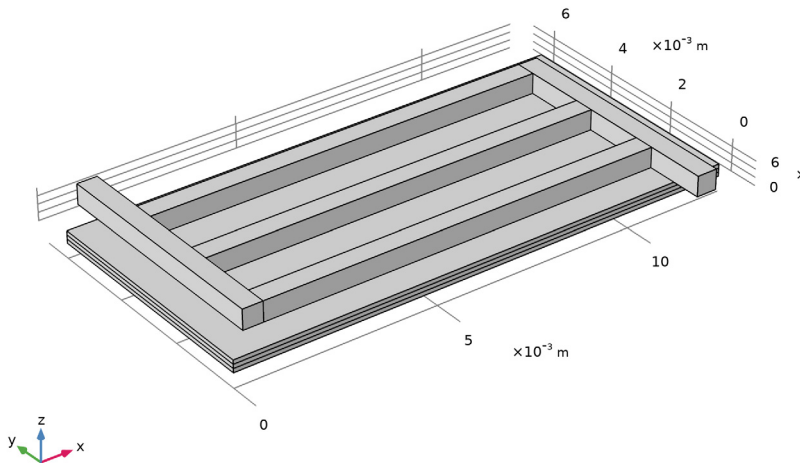



GLOBAL DEFINITIONS

Geometry Parameters

- 1 In the **Model Builder** window, under **Global Definitions** click **Parameters 1**.
- 2 In the **Settings** window for **Parameters**, type Geometry Parameters in the **Label** text field.

Physics Parameters

Some parameters were imported with the geometry sequence. Import some additional physics parameters from a text file.

- 1 In the **Home** toolbar, click  **Parameters** and choose **Add>Parameters**.
- 2 In the **Settings** window for **Parameters**, type Physics Parameters in the **Label** text field.
- 3 Locate the **Parameters** section. Click  **Load from File**.
- 4 Browse to the model's Application Libraries folder and double-click the file soec_physics_parameters.txt.

WATER ELECTROLYZER (WE)

Now define the current distribution in the gas diffusion electrodes and the electrolyte.

- 1 In the **Model Builder** window, under **Component 1 (comp1)** click **Water Electrolyzer (we)**.
- 2 In the **Settings** window for **Water Electrolyzer**, locate the **Domain Selection** section.
- 3 Click  **Clear Selection**.
- 4 Select Domains 1–3 only.
- 5 Locate the **H2 Gas Mixture** section. Find the **Transport mechanisms** subsection. Clear the **Include gas phase diffusion** check box.

Membrane 1

- 1 In the **Physics** toolbar, click  **Domains** and choose **Membrane**.
- 2 Select Domain 2 only.

Electrolyte Phase 1

Set up the electrolyte conductivity in the **Electrolyte Phase** node.

- 1 In the **Model Builder** window, click **Electrolyte Phase 1**.
- 2 In the **Settings** window for **Electrolyte Phase**, locate the **Electrolyte Charge Transport** section.
- 3 In the σ_1 text field, type sigma_1.

H2 Gas Diffusion Electrode I

Set up the properties of the **H2 Gas Diffusion Electrode** node. The details of electrode kinetics are set in the child node. Note that the reference equilibrium potential is calculated automatically when the default **Built in** option is used.

- 1 In the **Physics** toolbar, click  **Domains** and choose **H2 Gas Diffusion Electrode**.
- 2 In the **Settings** window for **H2 Gas Diffusion Electrode**, locate the **Domain Selection** section.
- 3 From the **Selection** list, choose **Cathode**.
- 4 Locate the **Electrode Charge Transport** section. In the σ_s text field, type `sigmaeff_s`.
- 5 Locate the **Effective Electrolyte Charge Transport** section. In the ϵ_1 text field, type `por_1`.

H2 Gas Diffusion Electrode Reaction I

- 1 In the **Model Builder** window, expand the **H2 Gas Diffusion Electrode I** node, then click **H2 Gas Diffusion Electrode Reaction I**.
- 2 In the **Settings** window for **H2 Gas Diffusion Electrode Reaction**, locate the **Electrode Kinetics** section.
- 3 In the $i_{0,\text{ref}}(T)$ text field, type `i0_H2`.
- 4 Locate the **Active Specific Surface Area** section. In the a_v text field, type `S`.

O2 Gas Diffusion Electrode I

Similarly, set up the properties of the **O2 Gas Diffusion Electrode** node. The details of electrode kinetics are set in the child node. Note that the reference equilibrium potential is calculated automatically when the default **Built in** option is used.

- 1 In the **Physics** toolbar, click  **Domains** and choose **O2 Gas Diffusion Electrode**.
- 2 In the **Settings** window for **O2 Gas Diffusion Electrode**, locate the **Domain Selection** section.
- 3 From the **Selection** list, choose **Anode**.
- 4 Locate the **Electrode Charge Transport** section. In the σ_s text field, type `sigmaeff_s`.
- 5 Locate the **Effective Electrolyte Charge Transport** section. In the ϵ_1 text field, type `por_1`.

O2 Gas Diffusion Electrode Reaction I

- 1 In the **Model Builder** window, expand the **O2 Gas Diffusion Electrode I** node, then click **O2 Gas Diffusion Electrode Reaction I**.
- 2 In the **Settings** window for **O2 Gas Diffusion Electrode Reaction**, locate the **Electrode Kinetics** section.
- 3 In the $i_{0,\text{ref}}(T)$ text field, type `i0_O2`.

- 4 In the α_a text field, type 3.5.
- 5 Locate the **Active Specific Surface Area** section. In the α_v text field, type S.

Electronic Conducting Phase I

Finally, set up the boundary conditions.

- 1 In the **Model Builder** window, click **Electronic Conducting Phase I**.

Electric Ground I

- 1 In the **Physics** toolbar, click  **Attributes** and choose **Electric Ground**.
- 2 In the **Settings** window for **Electric Ground**, locate the **Boundary Selection** section.
- 3 From the **Selection** list, choose **Cathode Current Collector**.

Electronic Conducting Phase I

In the **Model Builder** window, click **Electronic Conducting Phase I**.

Electrode Current I

- 1 In the **Physics** toolbar, click  **Attributes** and choose **Electrode Current**.
- 2 In the **Settings** window for **Electrode Current**, locate the **Electrode Current** section.
- 3 From the list, choose **Average current density**.
- 4 Locate the **Boundary Selection** section. From the **Selection** list, choose **Anode Current Collector**.
- 5 Locate the **Electrode Current** section. In the $i_{s,average}$ text field, type I_avg.

GLOBAL DEFINITIONS

Default Model Inputs

Default Model Inputs node can be used to set the **Temperature** for the entire model. This node may be accessed by multiple physics nodes.

- 1 In the **Model Builder** window, under **Global Definitions** click **Default Model Inputs**.
- 2 In the **Settings** window for **Default Model Inputs**, locate the **Browse Model Inputs** section.
- 3 In the tree, select **General>Temperature (K) - minput.T**.
- 4 Find the **Expression for remaining selection** subsection. In the **Temperature** text field, type T.



MESH I

The physics settings for the first part of the tutorial are now complete. Add a user-defined mesh.

Size 1

- 1 In the **Model Builder** window, under **Component 1 (comp1)** right-click **Mesh 1** and choose **Size**.
- 2 In the **Settings** window for **Size**, click to expand the **Element Size Parameters** section.
- 3 Locate the **Element Size** section. Click the **Custom** button.
- 4 Locate the **Element Size Parameters** section. Select the **Maximum element size** check box.
- 5 In the associated text field, type $H_{ch} \cdot 0.8$.

Swept 1

- 1 In the **Mesh** toolbar, click  **Swept**.
- 2 In the **Settings** window for **Swept**, locate the **Domain Selection** section.
- 3 From the **Geometric entity level** list, choose **Domain**.
- 4 Select Domains 5–7 only.
- 5 Click  **Build Selected**.

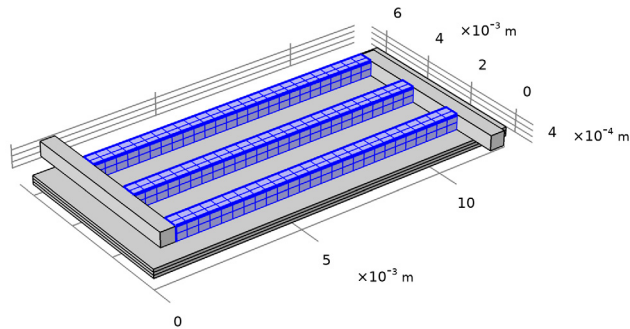



Boundary Layers 1

Also add boundary layer mesh nodes at this stage. These are actually not needed for the first calculation, but will improve the accuracy and convergence of the solution for the second part of the tutorial when mass transport and convection has been added.

- 1 In the **Mesh** toolbar, click  **Boundary Layers**.
- 2 In the **Settings** window for **Boundary Layers**, locate the **Geometric Entity Selection** section.
- 3 From the **Geometric entity level** list, choose **Domain**.
- 4 Select Domains 5–7 only.

Boundary Layer Properties

- 1 In the **Model Builder** window, click **Boundary Layer Properties**.
- 2 In the **Settings** window for **Boundary Layer Properties**, locate the **Boundary Selection** section.
- 3 Click  **Paste Selection**.
- 4 In the **Paste Selection** dialog box, type 21-23, 25, 28-30, 32, 35-37, 39 in the **Selection** text field.
- 5 Click **OK**.
- 6 In the **Settings** window for **Boundary Layer Properties**, locate the **Boundary Layer Properties** section.
- 7 In the **Number of boundary layers** text field, type 2.
- 8 In the **Boundary layer stretching factor** text field, type 1.3.
- 9 From the **Thickness of first layer** list, choose **Manual**.
- 10 In the **Thickness** text field, type $H_{ch}/10$.
- 11 Click  **Build Selected**.

Free Tetrahedral I

- 1 In the **Mesh** toolbar, click  **Free Tetrahedral**.
- 2 In the **Settings** window for **Free Tetrahedral**, locate the **Domain Selection** section.
- 3 From the **Geometric entity level** list, choose **Domain**.
- 4 Select Domains 4 and 8 only.

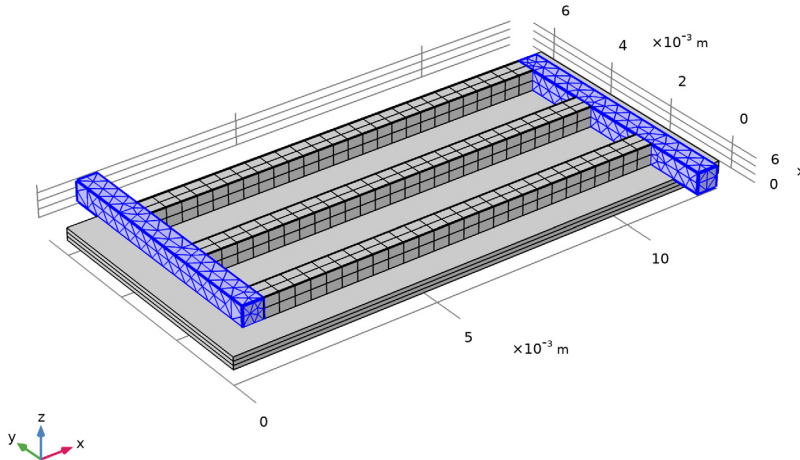

5 Click  **Build Selected**.



Boundary Layers 2

- 1 In the **Model Builder** window, under **Component 1 (comp1)**>**Mesh 1** right-click **Boundary Layers 1** and choose **Duplicate**.
- 2 In the **Settings** window for **Boundary Layers**, locate the **Geometric Entity Selection** section.
- 3 Click  **Clear Selection**.
- 4 Select Domains 4 and 8 only.



Boundary Layer Properties

- 1 In the **Model Builder** window, expand the **Boundary Layers 2** node, then click **Boundary Layer Properties**.
- 2 In the **Settings** window for **Boundary Layer Properties**, locate the **Boundary Selection** section.
- 3 Click  **Clear Selection**.
- 4 Click  **Paste Selection**.
- 5 In the **Paste Selection** dialog box, type 14-18, 24, 31, 38, 41, 43-45, 47, 49, 51, 52 in the **Selection** text field.
- 6 Click **OK**.

Boundary Layers 2

In the **Model Builder** window, right-click **Boundary Layers 2** and choose **Build Selected**.

Free Triangular 1

- 1 In the **Mesh** toolbar, click  **Boundary** and choose **Free Triangular**.
- 2 In the **Settings** window for **Free Triangular**, locate the **Boundary Selection** section.
- 3 From the **Selection** list, choose **Cathode Current Collector**.
- 4 Click  **Build Selected**.

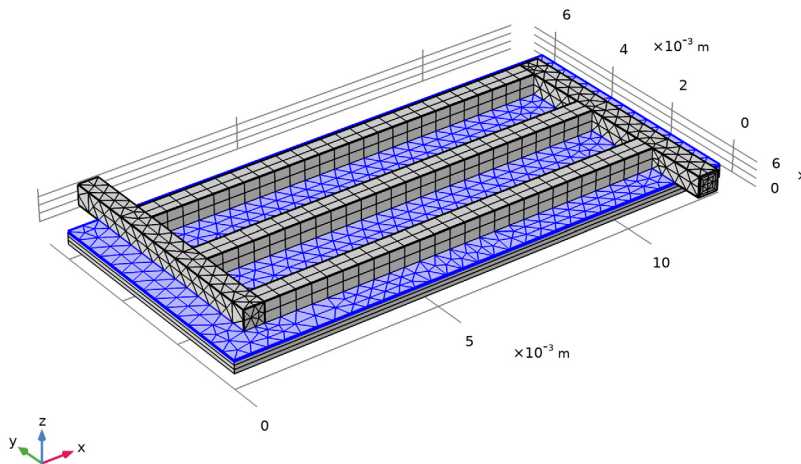

Swept 2

In the **Mesh** toolbar, click  **Swept**.



Distribution 1

- 1 Right-click **Swept 2** and choose **Distribution**.
- 2 In the **Settings** window for **Distribution**, locate the **Domain Selection** section.
- 3 Click  **Clear Selection**.
- 4 Select Domain 3 only.
- 5 Locate the **Distribution** section. From the **Distribution type** list, choose **Predefined**.
- 6 In the **Element ratio** text field, type 2.
- 7 Select the **Reverse direction** check box.

Distribution 2

- 1 In the **Model Builder** window, right-click **Swept 2** and choose **Distribution**.
- 2 In the **Settings** window for **Distribution**, locate the **Domain Selection** section.
- 3 Click  **Clear Selection**.
- 4 Select Domain 2 only.
- 5 Locate the **Distribution** section. In the **Number of elements** text field, type 2.

Distribution 3

- 1 In the **Model Builder** window, under **Component 1 (comp1)>Mesh 1>Swept 2** right-click **Distribution 1** and choose **Duplicate**.
- 2 In the **Settings** window for **Distribution**, locate the **Domain Selection** section.
- 3 Click  **Clear Selection**.
- 4 Select Domain 1 only.
- 5 Locate the **Distribution** section. Clear the **Reverse direction** check box.
- 6 Click  **Build All**.

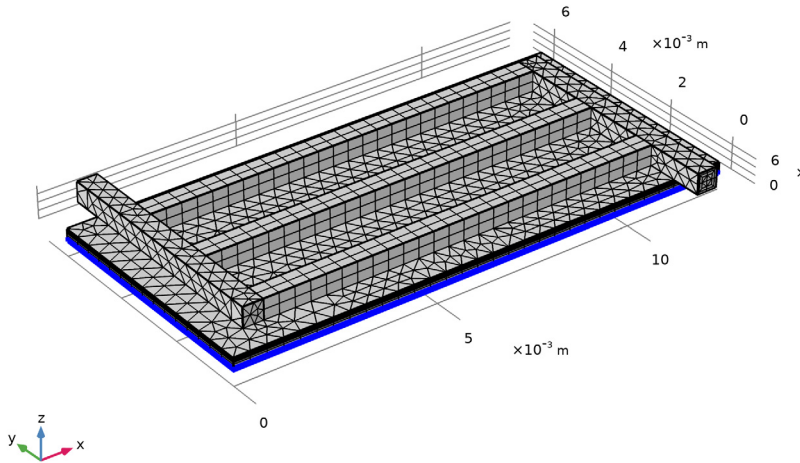

STUDY 1

The problem is now ready for solving.

1 In the **Home** toolbar, click  **Compute**.

RESULTS

Electrode Potential with Respect to Ground (we)

1 In the **Electrode Potential with Respect to Ground (we)** toolbar, click  **Plot**.

Inspect the potential plot. The plot should look as follows:

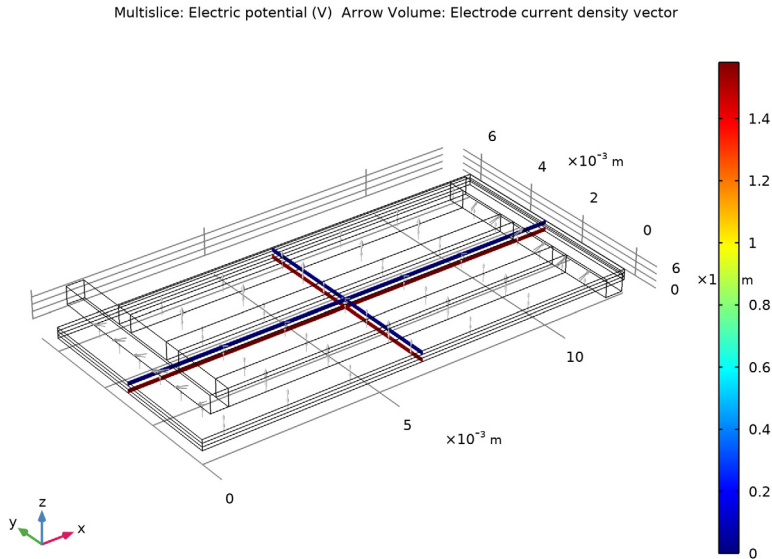

COMPONENT 1 (COMPI)

Now start with the second part of the tutorial which adds a **Free and Porous Media Flow** interface to the cathode side of the model, enables hydrogen gas phase diffusion in the **Water Electrolyzer** interface, and couples the distribution of hydrogen and water vapor to the electrochemistry.

ADD PHYSICS

1 In the **Home** toolbar, click  **Add Physics** to open the **Add Physics** window.

2 Go to the **Add Physics** window.

3 In the tree, select **Fluid Flow>Porous Media and Subsurface Flow>Free and Porous Media Flow (fp)**.

4 Click **Add to Component 1** in the window toolbar.

5 In the **Home** toolbar, click  **Add Physics** to close the **Add Physics** window.

FREE AND POROUS MEDIA FLOW (FP)

- 1 Select Domains 3–8 only.
- 2 In the **Settings** window for **Free and Porous Media Flow**, locate the **Domain Selection** section.
- 3 Click  **Create Selection**.
- 4 In the **Create Selection** dialog box, type Gas domains in the **Selection name** text field.
- 5 Click **OK**.
- 6 In the **Settings** window for **Free and Porous Media Flow**, locate the **Physical Model** section.
- 7 From the **Compressibility** list, choose **Compressible flow (Ma<0.3)**.
- 8 In the **Model Builder** window, click **Free and Porous Media Flow (fp)**.

Fluid and Matrix Properties 1

- 1 In the **Physics** toolbar, click  **Domains** and choose **Fluid and Matrix Properties**.
- 2 In the **Settings** window for **Fluid and Matrix Properties**, locate the **Domain Selection** section.
- 3 From the **Selection** list, choose **Cathode**.
- 4 Locate the **Porous Matrix Properties** section. From the ϵ_p list, choose **User defined**. In the associated text field, type por.
- 5 From the κ list, choose **User defined**. In the associated text field, type kappa.

Inlet 1

- 1 In the **Physics** toolbar, click  **Boundaries** and choose **Inlet**.
- 2 In the **Settings** window for **Inlet**, locate the **Boundary Selection** section.
- 3 From the **Selection** list, choose **Inlet**.
- 4 Locate the **Boundary Condition** section. From the list, choose **Mass flow**.
- 5 Locate the **Mass Flow** section. In the m text field, type Mflux_in.

Outlet 1

- 1 In the **Physics** toolbar, click  **Boundaries** and choose **Outlet**.
- 2 In the **Settings** window for **Outlet**, locate the **Boundary Selection** section.
- 3 From the **Selection** list, choose **Outlet**.
- 4 Locate the **Pressure Conditions** section. Select the **Normal flow** check box.

MULTIPHYSICS

Reacting Flow, H2 Gas Phase I (rfh1)

In the **Physics** toolbar, click  **Multiphysics Couplings** and choose **Domain>Reacting Flow, H2 Gas Phase**.

WATER ELECTROLYZER (WE)

- 1 In the **Model Builder** window, under **Component 1 (comp1)** click **Water Electrolyzer (we)**.
- 2 In the **Settings** window for **Water Electrolyzer**, locate the **Domain Selection** section.
- 3 From the **Selection** list, choose **All domains**.
- 4 Locate the **H2 Gas Mixture** section. Find the **Transport mechanisms** subsection. Select the **Include gas phase diffusion** check box.

H2 Flow Channel I

- 1 In the **Physics** toolbar, click  **Domains** and choose **H2 Flow Channel**.
- 2 In the **Settings** window for **H2 Flow Channel**, locate the **Domain Selection** section.
- 3 From the **Selection** list, choose **Channel Domains**.

H2 Gas Diffusion Electrode I

- 1 In the **Model Builder** window, click **H2 Gas Diffusion Electrode I**.
- 2 In the **Settings** window for **H2 Gas Diffusion Electrode**, locate the **Gas Transport** section.
- 3 In the ε_g text field, type por.

H2 Gas Phase I

Note that the settings on the **H2 Gas Phase** node are either the default option or automatically set by the multiphysics coupling node. Set up the required boundary conditions and initial values.

- 1 In the **Model Builder** window, click **H2 Gas Phase I**.

H2 Inlet I

- 1 In the **Physics** toolbar, click  **Attributes** and choose **H2 Inlet**.
- 2 In the **Settings** window for **H2 Inlet**, locate the **Boundary Selection** section.
- 3 From the **Selection** list, choose **Inlet**.
- 4 Locate the **Mixture Specification** section. From the list, choose **Mass flow rates**.
- 5 In the J_{0,H_2O} text field, type `Mflux_in`.

H2 Gas Phase I

In the **Model Builder** window, click **H2 Gas Phase I**.

H2 Outlet 1

- 1 In the **Physics** toolbar, click  **Attributes** and choose **H2 Outlet**.
- 2 In the **Settings** window for **H2 Outlet**, locate the **Boundary Selection** section.
- 3 From the **Selection** list, choose **Outlet**.

Initial Values 1

- 1 In the **Model Builder** window, click **Initial Values 1**.
- 2 In the **Settings** window for **Initial Values**, locate the **Initial Values** section.
- 3 In the x_{0,H_2O} text field, type $0.95*(1-x/(W_cell*stoich))$.

STUDY 1

The concentration-dependent model is now ready for solving. Use a sequence of study steps, solving first for the current distribution initialization, then the flow, and finally the fully coupled problem. By solving for only one set of physics at a time in individual steps, suitable initial values automatically propagate to the final study step where the complete problem is solved.

Step 1: Current Distribution Initialization

- 1 In the **Model Builder** window, under **Study 1** click **Step 1: Current Distribution Initialization**.
- 2 In the **Settings** window for **Current Distribution Initialization**, locate the **Physics and Variables Selection** section.
- 3 In the table, clear the **Solve for** check box for **Free and Porous Media Flow (fp)**.
- 4 In the table, clear the **Solve for** check box for **Reacting Flow, H2 Gas Phase 1 (rfh1)**.

Step 2: Stationary

- 1 In the **Model Builder** window, click **Step 2: Stationary**.
- 2 In the **Settings** window for **Stationary**, locate the **Physics and Variables Selection** section.
- 3 In the table, clear the **Solve for** check box for **Water Electrolyzer (we)**.
- 4 In the table, clear the **Solve for** check box for **Reacting Flow, H2 Gas Phase 1 (rfh1)**.



Stationary 2

- 1 In the **Study** toolbar, click  **Study Steps** and choose **Stationary>Stationary**.
Remove the old study sequence and generate a new one.

Solver Configurations

In the **Model Builder** window, under **Study 1** right-click **Solver Configurations** and choose **Delete Configurations**.

Solution 1 (sol1)

- 1 In the **Study** toolbar, click  **Show Default Solver**.
- 2 In the **Model Builder** window, expand the **Solution 1 (sol1)** node.
- 3 In the **Model Builder** window, expand the **Study 1>Solver Configurations>Solution 1 (sol1)>Stationary Solver 3** node.
- 4 Right-click **Stationary Solver 3** and choose **Fully Coupled**.
- 5 In the **Study** toolbar, click  **Compute**.

The problem should solve in about two minutes.

RESULTS

Start the postprocessing of the solution by inspecting and polishing the default plot for the velocity field.

Slice

- 1 In the **Model Builder** window, expand the **Results>Velocity (fp)** node, then click **Slice**.
- 2 In the **Settings** window for **Slice**, locate the **Plane Data** section.
- 3 From the **Plane** list, choose **xy-planes**.
- 4 From the **Entry method** list, choose **Coordinates**.
- 5 In the **z-coordinates** text field, type $H_{\text{cell}} - H_{\text{ch}}/2$.
- 6 In the **Velocity (fp)** toolbar, click  **Plot**.

Streamline 1

- 1 In the **Model Builder** window, right-click **Velocity (fp)** and choose **Streamline**.
- 2 In the **Settings** window for **Streamline**, click **Replace Expression** in the upper-right corner of the **Expression** section. From the menu, choose **Component 1 (comp1)>Free and Porous Media Flow>Velocity and pressure>u,v,w - Velocity field**.
- 3 Locate the **Selection** section. From the **Selection** list, choose **Inlet**.
- 4 Locate the **Coloring and Style** section. Find the **Point style** subsection. From the **Type** list, choose **Arrow**.
- 5 From the **Arrow distribution** list, choose **Equal inverse time**.
- 6 From the **Color** list, choose **Black**.

7 In the **Velocity (fp)** toolbar, click  **Plot**.

Slice: Velocity magnitude (m/s) Streamline: Velocity field

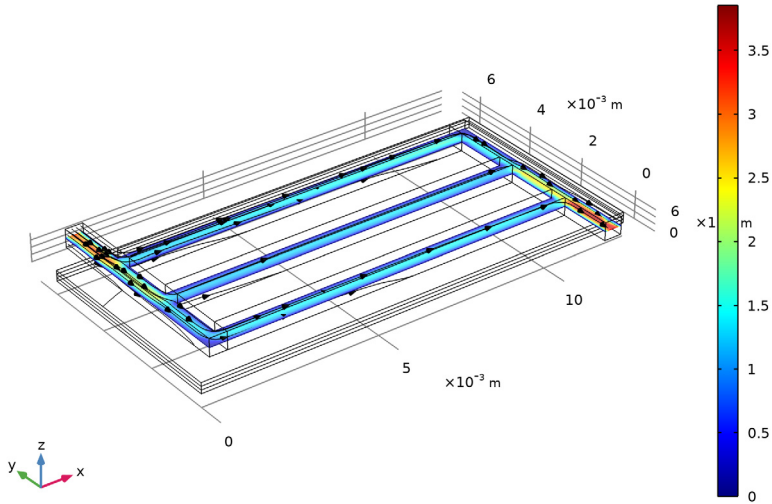

Density

The density of the gas mixture will change as water is replaced by hydrogen in the gas stream. Plot the density as follows:

- 1 In the **Home** toolbar, click  **Add Plot Group** and choose **3D Plot Group**.
- 2 In the **Settings** window for **3D Plot Group**, type **Density** in the **Label** text field.

Surface 1

- 1 Right-click **Density** and choose **Surface**.
- 2 In the **Settings** window for **Surface**, click **Replace Expression** in the upper-right corner of the **Expression** section. From the menu, choose **Component 1 (comp1) > Free and Porous Media Flow > Material properties > fp.rho - Density - kg/m³**.

3 In the **Density** toolbar, click  **Plot**.

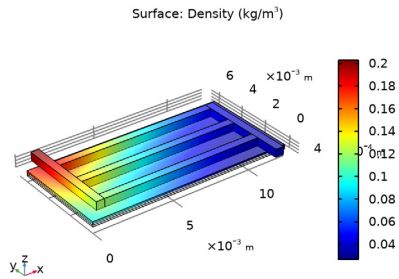

Viscosity

Also the viscosity will change in the gas stream.

- 1 In the **Home** toolbar, click  **Add Plot Group** and choose **3D Plot Group**.
- 2 In the **Settings** window for **3D Plot Group**, type *Viscosity* in the **Label** text field.

Surface 1

- 1 Right-click **Viscosity** and choose **Surface**.
- 2 In the **Settings** window for **Surface**, click **Replace Expression** in the upper-right corner of the **Expression** section. From the menu, choose **Component 1 (comp1) > Free and Porous Media Flow > Material properties > fp.mu - Dynamic viscosity - Pa*s**.
- 3 In the **Viscosity** toolbar, click  **Plot**.

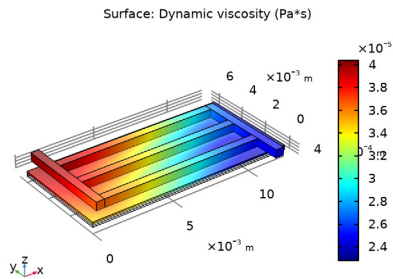

Mole Fraction, H₂, Surface (we)

Default plots are created for the hydrogen and water molar fractions.

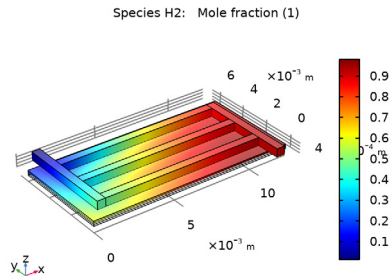

Mole Fraction, H₂O, Surface (we)

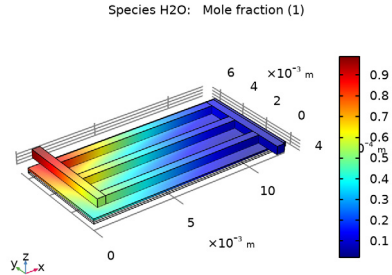

Molar Fraction and Flux, H₂

Create a plot for the hydrogen molar fraction and flux as follows:

- 1 In the **Home** toolbar, click  **Add Plot Group** and choose **3D Plot Group**.
- 2 In the **Settings** window for **3D Plot Group**, type Molar Fraction and Flux, H₂ in the **Label** text field.
- 3 Locate the **Plot Settings** section. Clear the **Plot dataset edges** check box.

Streamline 1

- 1 Right-click **Molar Fraction and Flux, H₂** and choose **Streamline**.
- 2 In the **Settings** window for **Streamline**, click **Replace Expression** in the upper-right corner of the **Expression** section. From the menu, choose **Component 1 (comp1) > Water Electrolyzer > Species H2 > we.tfluxH2x, ..., we.tfluxH2z - Total flux**.
- 3 Locate the **Streamline Positioning** section. In the **Number** text field, type 30.
- 4 Locate the **Selection** section. From the **Selection** list, choose **Outlet**.

- 5 Locate the **Coloring and Style** section. Find the **Point style** subsection. From the **Type** list, choose **Arrow**.
- 6 From the **Arrow distribution** list, choose **Equal inverse time**.
- 7 From the **Color** list, choose **Black**.

Selection 1

- 1 Right-click **Streamline 1** and choose **Selection**.
- 2 In the **Settings** window for **Selection**, locate the **Selection** section.
- 3 From the **Selection** list, choose **Channel Domains**.

Volume 1

- 1 In the **Model Builder** window, right-click **Molar Fraction and Flux, H2** and choose **Volume**.
- 2 In the **Settings** window for **Volume**, click **Replace Expression** in the upper-right corner of the **Expression** section. From the menu, choose **Component 1 (comp1)> Water Electrolyzer>Species H2>we.xH2 - Mole fraction**.

Selection 1

- 1 Right-click **Volume 1** and choose **Selection**.
- 2 In the **Settings** window for **Selection**, locate the **Selection** section.
- 3 From the **Selection** list, choose **Cathode**.
- 4 Click the  **Show Grid** button in the **Graphics** toolbar.

- 5 In the **Molar Fraction and Flux, H2** toolbar, click  **Plot**.

Streamline: Total flux Volume: Mole fraction (1)

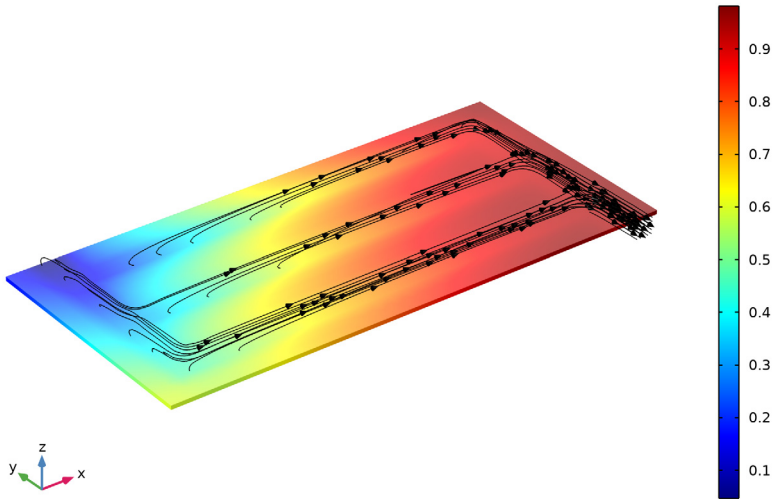

Cross-Sectional Electrolyte Current Density

Finally, plot the current distribution across the electrolyte layer as follows:

- 1 In the **Home** toolbar, click  **Add Plot Group** and choose **3D Plot Group**.
- 2 In the **Settings** window for **3D Plot Group**, type **Cross-Sectional Electrolyte Current Density** in the **Label** text field.
- 3 Locate the **Plot Settings** section. Clear the **Plot dataset edges** check box.

Slice 1

- 1 Right-click **Cross-Sectional Electrolyte Current Density** and choose **Slice**.
- 2 In the **Settings** window for **Slice**, click **Replace Expression** in the upper-right corner of the **Expression** section. From the menu, choose **Component 1 (comp1)>Water Electrolyzer>Electrolyte current density vector - A/m²>we.llz - Electrolyte current density vector, z component**.
- 3 Locate the **Plane Data** section. From the **Plane** list, choose **xy-planes**.
- 4 From the **Entry method** list, choose **Coordinates**.
- 5 In the **z-coordinates** text field, type $H_gde+H_e1/2$.

6 In the **Cross-Sectional Electrolyte Current Density** toolbar, click  **Plot**.

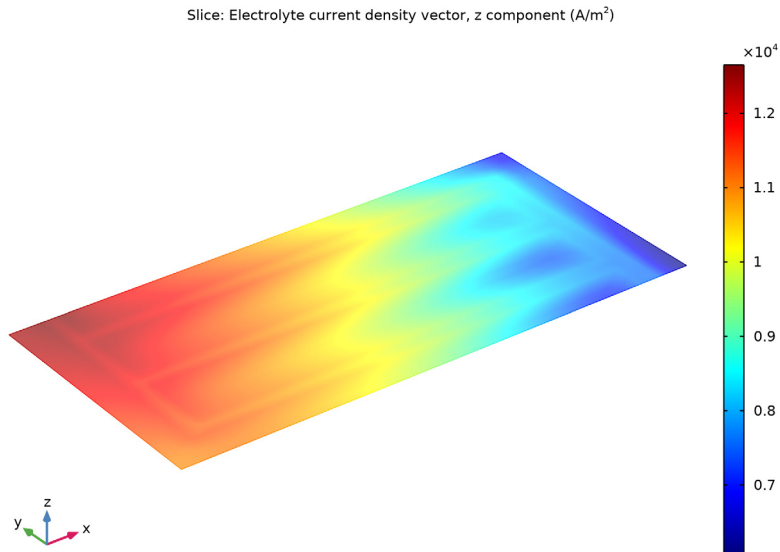

Appendix - Geometry Modeling Instructions

From the **File** menu, choose **New**.

NEW

In the **New** window, click  **Model Wizard**.

MODEL WIZARD

1 In the **Model Wizard** window, click  **3D**.

2 Click  **Done**.

GLOBAL DEFINITIONS

Geometry Parameters

1 In the **Model Builder** window, under **Global Definitions** click **Parameters I**.

2 In the **Settings** window for **Parameters**, type Geometry Parameters in the **Label** text field.

3 Locate the **Parameters** section. Click  **Load from File**.

- 4 Browse to the model's Application Libraries folder and double-click the file `soec_geom_parameters.txt`.

GEOMETRY I

Anode

- 1 In the **Geometry** toolbar, click  **Block**.
- 2 In the **Settings** window for **Block**, type Anode in the **Label** text field.
- 3 Locate the **Size and Shape** section. In the **Width** text field, type W_{cell} .
- 4 In the **Depth** text field, type D_{cell} .
- 5 In the **Height** text field, type H_{gde} .
- 6 Locate the **Selections of Resulting Entities** section. Select the **Resulting objects selection** check box.

Electrolyte

- 1 Right-click **Anode** and choose **Duplicate**.
- 2 In the **Settings** window for **Block**, type Electrolyte in the **Label** text field.
- 3 Locate the **Position** section. In the **z** text field, type H_{gde} .

Cathode

- 1 Right-click **Electrolyte** and choose **Duplicate**.
- 2 In the **Settings** window for **Block**, type Cathode in the **Label** text field.
- 3 Locate the **Position** section. In the **z** text field, type $H_{gde}+H_{e1}$.

Work Plane 1 (wp1)

- 1 In the **Geometry** toolbar, click  **Work Plane**.
- 2 In the **Settings** window for **Work Plane**, locate the **Plane Definition** section.
- 3 In the **z-coordinate** text field, type $H_{cell}-H_{ch}$.

Work Plane 1 (wp1)>Plane Geometry

In the **Model Builder** window, click **Plane Geometry**.

Work Plane 1 (wp1)>Rectangle 1 (r1)

- 1 In the **Work Plane** toolbar, click  **Rectangle**.
- 2 In the **Settings** window for **Rectangle**, locate the **Size and Shape** section.
- 3 In the **Width** text field, type W_{ch} .
- 4 In the **Height** text field, type $N_{ch}*(W_{ch}+W_{rib})$.
- 5 Locate the **Position** section. In the **xw** text field, type $W_{rib}/2$.

6 In the **yw** text field, type $W_{rib}/2$.

Work Plane 1 (wp1)>Rectangle 2 (r2)

1 Right-click **Component 1 (comp1)>Geometry 1>Work Plane 1 (wp1)>Plane Geometry>Rectangle 1 (r1)** and choose **Duplicate**.

2 In the **Settings** window for **Rectangle**, locate the **Position** section.

3 In the **xw** text field, type $W_{rib}/2+L_{ch}+W_{ch}$.

4 In the **yw** text field, type $-W_{rib}/2$.

Work Plane 1 (wp1)>Rectangle 3 (r3)

1 In the **Work Plane** toolbar, click  **Rectangle**.

2 In the **Settings** window for **Rectangle**, locate the **Size and Shape** section.

3 In the **Width** text field, type L_{ch} .

4 In the **Height** text field, type W_{ch} .

5 Locate the **Position** section. In the **xw** text field, type $W_{rib}/2+W_{ch}$.

6 In the **yw** text field, type $W_{rib}/2$.

Work Plane 1 (wp1)>Array 1 (arr1)

1 In the **Work Plane** toolbar, click  **Transforms** and choose **Array**.

2 Select the object **r3** only.

3 In the **Settings** window for **Array**, locate the **Size** section.

4 In the **yw size** text field, type N_{ch} .

5 Locate the **Displacement** section. In the **yw** text field, type $W_{ch}+W_{rib}$.

6 In the **Work Plane** toolbar, click  **Build All**.

Channel Domains

1 In the **Model Builder** window, right-click **Geometry 1** and choose **Extrude**.

2 In the **Settings** window for **Extrude**, type Channel Domains in the **Label** text field.

3 Locate the **Distances** section. In the table, enter the following settings:

Distances (m)

H_{ch}

4 Locate the **Selections of Resulting Entities** section. Select the **Resulting objects selection** check box.

Form Union (fin)

In the **Model Builder** window, right-click **Form Union (fin)** and choose **Build Selected**.

Inlet

- 1 In the **Geometry** toolbar, click  **Selections** and choose **Explicit Selection**.
- 2 In the **Settings** window for **Explicit Selection**, type Inlet in the **Label** text field.
- 3 Locate the **Entities to Select** section. From the **Geometric entity level** list, choose **Boundary**.
- 4 On the object **fin**, select Boundary 19 only.

Outlet

- 1 In the **Geometry** toolbar, click  **Selections** and choose **Explicit Selection**.
- 2 In the **Settings** window for **Explicit Selection**, type Outlet in the **Label** text field.
- 3 Locate the **Entities to Select** section. From the **Geometric entity level** list, choose **Boundary**.
- 4 On the object **fin**, select Boundary 42 only.

Cathode Current Collector

- 1 In the **Geometry** toolbar, click  **Selections** and choose **Explicit Selection**.
- 2 In the **Settings** window for **Explicit Selection**, type Cathode Current Collector in the **Label** text field.
- 3 Locate the **Entities to Select** section. From the **Geometric entity level** list, choose **Boundary**.
- 4 On the object **fin**, select Boundaries 10, 26, 33, and 40 only.

Anode Current Collector

- 1 In the **Geometry** toolbar, click  **Selections** and choose **Explicit Selection**.
- 2 In the **Settings** window for **Explicit Selection**, type Anode Current Collector in the **Label** text field.
- 3 Locate the **Entities to Select** section. From the **Geometric entity level** list, choose **Boundary**.
- 4 On the object **fin**, select Boundary 3 only.