

Solar Panel in Periodic Flow Template

Introduction

This model is a template MPH-file containing the geometry and mesh used by the *Solar Panel in Periodic Flow* model.

Application Library path: CFD_Module/Fluid-Structure_Interaction/
solar_panel_geom



Modeling Instructions

From the **File** menu, choose **New**.

NEW

In the **New** window, click  **Model Wizard**.

MODEL WIZARD

- 1 In the **Model Wizard** window, click  **3D**.
- 2 In the **Select Physics** tree, select **Fluid Flow>Single-Phase Flow>Turbulent Flow>Turbulent Flow, k- ϵ (spf)**.
- 3 Click **Add**.
- 4 Click  **Study**.
- 5 In the **Select Study** tree, select **General Studies>Stationary**.
- 6 Click  **Done**.

GLOBAL DEFINITIONS

Parameters 1

- 1 In the **Model Builder** window, under **Global Definitions** click **Parameters 1**.
- 2 In the **Settings** window for **Parameters**, locate the **Parameters** section.
- 3 In the table, enter the following settings:

Name	Expression	Value	Description
Utop	25[m/s]	25 m/s	Velocity at top, Couette flow
yLen	6[m]	6 m	Streamwise box length
yEnd	4[m]	4 m	Streamwise box end point

DEFINITIONS

In the **Model Builder** window, expand the **Component 1 (comp1)>Definitions** node.

GEOMETRY 1

Import the geometry of the solar panel.

Import 1 (imp1)



- 1 In the **Model Builder** window, expand the **Component 1 (comp1)>Geometry 1** node.
- 2 Right-click **Geometry 1** and choose **Import**.
- 3 In the **Settings** window for **Import**, locate the **Import** section.
- 4 Click **Browse**.
- 5 Browse to the model's Application Libraries folder and double-click the file `solar_panel_geom_solid.mphbin`.
- 6 Click **Import**.

Inscribe the solar panel in what will later become the fluid domains.

Block 1 (blk1)

- 1 In the **Geometry** toolbar, click  **Block**.
- 2 In the **Settings** window for **Block**, locate the **Size and Shape** section.
- 3 In the **Width** text field, type 3[m].
- 4 In the **Depth** text field, type yLen.
- 5 In the **Height** text field, type 6[m].
- 6 Locate the **Position** section. In the **y** text field, type -2[m].

Difference 1 (dif1)

- 1 In the **Geometry** toolbar, click  **Booleans and Partitions** and choose **Difference**.
- 2 Select the object **blk1** only.
- 3 In the **Settings** window for **Difference**, locate the **Difference** section.
- 4 Find the **Objects to subtract** subsection. Select the  **Activate Selection** toggle button.
- 5 Select the object **imp1** only.
- 6 Select the **Keep input objects** check box.

Delete the parts of the structure that will not be simulated.

Delete Entities 1 (del1)

- 1 Right-click **Geometry 1** and choose **Delete Entities**.
- 2 In the **Settings** window for **Delete Entities**, locate the **Entities or Objects to Delete** section.

- 3 From the **Geometric entity level** list, choose **Domain**.
- 4 On the object **blk1**, select Domain 1 only.
- 5 On the object **dif1**, select Domains 2 and 3 only.
- 6 On the object **impl**, select Domains 4 and 5 only.

Union 1 (un1)

- 1 In the **Geometry** toolbar, click  **Booleans and Partitions** and choose **Union**.
- 2 Select the objects **dell(2)** and **dell(3)** only.

Create a fluid domain tall enough to capture the boundary layer.

Extrude 1 (ext1)

- 1 In the **Geometry** toolbar, click  **Extrude**.
- 2 On the object **un1**, select Boundary 4 only.
- 3 In the **Settings** window for **Extrude**, locate the **Distances** section.
- 4 In the table, enter the following settings:

Distances (m)
19[m]

Next, partition the geometry in order to facilitate the creation of a mapped mesh.

Work Plane 1 (wp1)

- 1 In the **Geometry** toolbar, click  **Work Plane**.
- 2 In the **Settings** window for **Work Plane**, locate the **Plane Definition** section.
- 3 From the **Plane type** list, choose **Face parallel**.
- 4 On the object **ext1**, select Boundary 166 only.

Partition Domains 1 (pard1)

- 1 In the **Geometry** toolbar, click  **Booleans and Partitions** and choose **Partition Domains**.
- 2 On the object **ext1**, select Domains 6, 8, 15, and 16 only.

Work Plane 2 (wp2)

- 1 In the **Geometry** toolbar, click  **Work Plane**.
- 2 In the **Settings** window for **Work Plane**, locate the **Plane Definition** section.
- 3 From the **Plane type** list, choose **Face parallel**.
- 4 On the object **pard1**, select Boundary 189 only.

Partition Domains 2 (pard2)

- 1 In the **Geometry** toolbar, click  **Booleans and Partitions** and choose **Partition Domains**.
- 2 On the object **pard1**, select Domains 3, 17, and 23–29 only.

Delete Entities 2 (del2)

- 1 Right-click **Geometry I** and choose **Delete Entities**.
- 2 On the object **pard2**, select Boundaries 189, 192, 199, 203, 208, 215, 219, 223, and 230 only.

Partition Domains 3 (pard3)

- 1 In the **Geometry** toolbar, click  **Booleans and Partitions** and choose **Partition Domains**.
- 2 On the object **del2**, select Domain 7 only.
- 3 In the **Settings** window for **Partition Domains**, locate the **Partition Domains** section.
- 4 From the **Partition with** list, choose **Extended faces**.
- 5 On the object **del2**, select Boundary 37 only.

Extrude 2 (ext2)

- 1 In the **Geometry** toolbar, click  **Extrude**.
- 2 In the **Settings** window for **Extrude**, locate the **General** section.
- 3 From the **Extrude from** list, choose **Faces**.
- 4 On the object **pard3**, select Boundaries 34, 42, 81, 89, 167, 173, 182, and 188 only.
- 5 Locate the **Distances** section. In the table, enter the following settings:

Distances (m)

0.02[m]

Extrude 3 (ext3)

- 1 In the **Geometry** toolbar, click  **Extrude**.
- 2 In the **Settings** window for **Extrude**, locate the **General** section.
- 3 From the **Extrude from** list, choose **Faces**.
- 4 On the object **ext2**, select Boundary 13 only.
- 5 Locate the **Distances** section. In the table, enter the following settings:

Distances (m)

0.02[m]

6 Select the **Reverse direction** check box.

Extrude 4 (ext4)

- 1 In the **Geometry** toolbar, click  **Extrude**.
- 2 In the **Settings** window for **Extrude**, locate the **General** section.
- 3 From the **Extrude from** list, choose **Faces**.
- 4 On the object **ext3**, select Boundary 125 only.
- 5 Locate the **Distances** section. In the table, enter the following settings:

Distances (m)

0.06[m]

Partition Domains 4 (pard4)

- 1 In the **Geometry** toolbar, click  **Booleans and Partitions** and choose **Partition Domains**.
- 2 On the object **ext4**, select Domain 16 only.
- 3 In the **Settings** window for **Partition Domains**, locate the **Partition Domains** section.
- 4 From the **Partition with** list, choose **Extended faces**.
- 5 On the object **ext4**, select Boundary 76 only.

Partition Domains 5 (pard5)

- 1 In the **Geometry** toolbar, click  **Booleans and Partitions** and choose **Partition Domains**.
- 2 On the object **pard4**, select Domain 16 only.
- 3 In the **Settings** window for **Partition Domains**, locate the **Partition Domains** section.
- 4 From the **Partition with** list, choose **Extended faces**.
- 5 On the object **pard4**, select Boundary 78 only.

Partition Domains 6 (pard6)

- 1 In the **Geometry** toolbar, click  **Booleans and Partitions** and choose **Partition Domains**.
- 2 On the object **pard5**, select Domain 14 only.
- 3 In the **Settings** window for **Partition Domains**, locate the **Partition Domains** section.
- 4 From the **Partition with** list, choose **Extended faces**.
- 5 On the object **pard5**, select Boundary 78 only.

Partition Domains 7 (pard7)

- 1 In the **Geometry** toolbar, click  **Booleans and Partitions** and choose **Partition Domains**.
- 2 On the object **pard6**, select Domain 14 only.
- 3 In the **Settings** window for **Partition Domains**, locate the **Partition Domains** section.
- 4 From the **Partition with** list, choose **Extended faces**.
- 5 On the object **pard6**, select Boundary 79 only.

Next, add selections for the walls, supports, symmetry boundaries, and structural materials.

Walls

- 1 In the **Geometry** toolbar, click  **Selections** and choose **Explicit Selection**.
- 2 In the **Settings** window for **Explicit Selection**, type Walls in the **Label** text field.
- 3 Locate the **Entities to Select** section. From the **Geometric entity level** list, choose **Boundary**.
- 4 On the object **pard7**, select Boundaries 3, 9–11, 14, 17–19, 22–28, 30, 31, 33–35, 38, 41–43, 45–47, 53–55, 57, 60, 63, 66, 69, 99–102, 104–106, 112–114, 116, 117, 120–123, 127, 128, 130–133, 141–143, 146–148, 150, 152–154, 156, 157, 159–161, 163, 164, 166–174, 176, 177, 179–181, 183–185, 187, 189, 192, 194–198, 200, 202–212, 214–216, 218, 219, 222–226, 229, 231, 234–236, 241, 242, 245–249, 254, 257–259, 263–265, 267, 268, 270–274, 276–282, 284–290, 292–298, 300–305, and 307–318 only.

Supports

- 1 In the **Geometry** toolbar, click  **Selections** and choose **Explicit Selection**.
- 2 In the **Settings** window for **Explicit Selection**, type Supports in the **Label** text field.
- 3 Locate the **Entities to Select** section. From the **Geometric entity level** list, choose **Boundary**.
- 4 On the object **pard7**, select Boundaries 29, 58, 93, 175, and 182 only.

Symmetry

- 1 In the **Geometry** toolbar, click  **Selections** and choose **Explicit Selection**.
- 2 In the **Settings** window for **Explicit Selection**, type Symmetry in the **Label** text field.
- 3 Locate the **Entities to Select** section. From the **Geometric entity level** list, choose **Boundary**.

- 4 On the object **pard7**, select Boundaries 8, 12, 15, 20, 32, 36, 39, 44, 48, 51, 56, 59, 62, 65, 68, 78, 81, 84, 91, 95, 103, 107, 110, 115, 118, 124, and 129 only.

Structural steel

- 1 In the **Geometry** toolbar, click  **Selections** and choose **Explicit Selection**.
- 2 In the **Settings** window for **Explicit Selection**, type Structural steel in the **Label** text field.
- 3 On the object **pard7**, select Domains 4–6, 8, 9, 11–17, 21, 22, 24, 25, 27, 33–35, 40, 42, 45, and 47 only.

Aluminum

- 1 In the **Geometry** toolbar, click  **Selections** and choose **Explicit Selection**.
- 2 In the **Settings** window for **Explicit Selection**, type Aluminum in the **Label** text field.
- 3 On the object **pard7**, select Domains 3, 7, 10, 18–20, 23, 26, 28, 30, 36, 38, 41, 43, and 46 only.

Glass

- 1 In the **Geometry** toolbar, click  **Selections** and choose **Explicit Selection**.
- 2 In the **Settings** window for **Explicit Selection**, type Glass in the **Label** text field.
- 3 On the object **pard7**, select Domains 29, 31, 32, 37, 39, and 44 only.

Finally, use the **Remove Details** functionality to remove unnecessary vertices.

Remove Details I (rmdl)

- 1 In the **Geometry** toolbar, click  **Remove Details**.
- 2 In the **Settings** window for **Remove Details**, locate the **Details to Remove** section.
- 3 Clear the **Short edges** check box.
- 4 Clear the **Small faces** check box.
- 5 Clear the **Sliver faces** check box.
- 6 Clear the **Narrow face regions** check box.
- 7 Clear the **Thin domains** check box.
- 8 Right-click **Remove Details I (rmdl)** and choose **Build All Objects**.

9 Click the  **Zoom Extents** button in the **Graphics** toolbar.

The final geometry with boundaries 1, 2, 4, 5, 6, 7, 134, 135, 319 and 320 hidden is shown in the figure below.

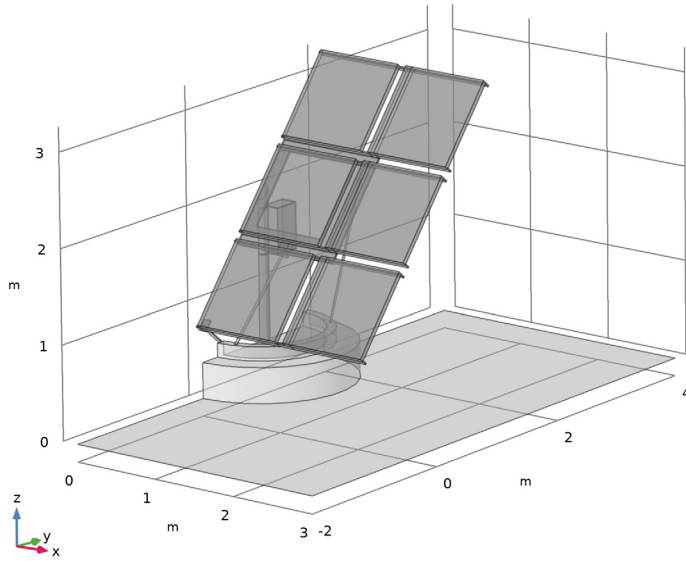

The geometry contains both the fluid and solid domains. Proceed with the mesh.

MESH 1

The following meshing instructions are rather long. In practice, advanced meshing requires several views, but to follow the instructions below, the best way is to use the selection list.

- 1 In the **Model Builder** window, under **Component 1 (comp1)** click **Mesh 1**.
- 2 In the **Settings** window for **Mesh**, locate the **Mesh Settings** section.
- 3 From the **Sequence type** list, choose **User-controlled mesh**.

Size

- 1 In the **Model Builder** window, under **Component 1 (comp1)>Mesh 1** click **Size**.
- 2 In the **Settings** window for **Size**, locate the **Element Size** section.
- 3 Click the **Custom** button.
- 4 Locate the **Element Size Parameters** section. In the **Minimum element size** text field, type 0.005.

5 Click  **Build Selected**.

Size 1

In the **Model Builder** window, right-click **Size 1** and choose **Delete**. Delete also **Corner Refinement 1** and **Free Tetrahedral 1**.

Mapped 1

- 1 In the **Model Builder** window, right-click **Mesh 1** and choose **More Operations>Mapped**.
- 2 Select Boundaries 162, 163, and 165 only.

Distribution 1

- 1 Right-click **Mapped 1** and choose **Distribution**.
- 2 Select Edges 249 and 366 only.
- 3 In the **Settings** window for **Distribution**, locate the **Distribution** section.
- 4 From the **Distribution type** list, choose **Predefined**.
- 5 In the **Number of elements** text field, type 26.
- 6 In the **Element ratio** text field, type 9.
- 7 Select the **Symmetric distribution** check box.

Distribution 2

- 1 In the **Model Builder** window, right-click **Mapped 1** and choose **Distribution**.
- 2 Select Edges 248, 250, 254, and 255 only.
- 3 In the **Settings** window for **Distribution**, locate the **Distribution** section.
- 4 From the **Distribution type** list, choose **Predefined**.
- 5 In the **Number of elements** text field, type 28.
- 6 In the **Element ratio** text field, type 3.
- 7 Select the **Symmetric distribution** check box.

Distribution 3

- 1 Right-click **Mapped 1** and choose **Distribution**.
- 2 Select Edges 247 and 253 only.
- 3 In the **Settings** window for **Distribution**, locate the **Distribution** section.
- 4 In the **Number of elements** text field, type 3.

Swept 1

- 1 In the **Model Builder** window, right-click **Mesh 1** and choose **Swept**.
- 2 In the **Settings** window for **Swept**, locate the **Domain Selection** section.

- 3 From the **Geometric entity level** list, choose **Domain**.
- 4 Select Domain 32 only.

Distribution 1

- 1 Right-click **Swept 1** and choose **Distribution**.
- 2 In the **Settings** window for **Distribution**, locate the **Distribution** section.
- 3 In the **Number of elements** text field, type 4.

Copy Domain 1

- 1 In the **Model Builder** window, right-click **Mesh 1** and choose **More Operations>Copy Domain**.
- 2 Select Domain 32 only.
- 3 In the **Settings** window for **Copy Domain**, locate the **Destination Domains** section.
- 4 Select the **Activate Selection** toggle button.
- 5 Select Domains 29 and 31 only.

Mapped 2

- 1 Right-click **Mesh 1** and choose **More Operations>Mapped**.
- 2 Select Boundaries 116 and 130 only.

Distribution 1

- 1 Right-click **Mapped 2** and choose **Distribution**.
- 2 Select Edges 161 and 190 only.
- 3 In the **Settings** window for **Distribution**, locate the **Distribution** section.
- 4 In the **Number of elements** text field, type 3.

Mapped 3

- 1 In the **Model Builder** window, right-click **Mesh 1** and choose **More Operations>Mapped**.
- 2 Select Boundaries 211 and 212 only.

Distribution 1

- 1 Right-click **Mapped 3** and choose **Distribution**.
- 2 Select Edges 367 and 370 only.
- 3 In the **Settings** window for **Distribution**, locate the **Distribution** section.
- 4 In the **Number of elements** text field, type 6.

Mapped 4

- 1 In the **Model Builder** window, right-click **Mesh 1** and choose **More Operations>Mapped**.

- 2 Select Boundaries 256, 259, and 266 only.
- 3 In the **Settings** window for **Mapped**, click to expand the **Reduce Element Skewness** section.
- 4 Select the **Adjust edge mesh** check box.

Distribution 1

- 1 Right-click **Mapped 4** and choose **Distribution**.
- 2 Select Edge 431 only.
- 3 In the **Settings** window for **Distribution**, locate the **Distribution** section.
- 4 In the **Number of elements** text field, type 3.

Distribution 2

- 1 In the **Model Builder** window, right-click **Mapped 4** and choose **Distribution**.
- 2 Select Edges 435 and 516 only.
- 3 In the **Settings** window for **Distribution**, locate the **Distribution** section.
- 4 From the **Distribution type** list, choose **Predefined**.
- 5 In the **Number of elements** text field, type 26.
- 6 In the **Element ratio** text field, type 9.
- 7 Select the **Symmetric distribution** check box.

Distribution 3

- 1 Right-click **Mapped 4** and choose **Distribution**.
- 2 Select Edge 436 only.
- 3 In the **Settings** window for **Distribution**, locate the **Distribution** section.
- 4 In the **Number of elements** text field, type 4.

Mapped 5

- 1 In the **Model Builder** window, right-click **Mesh 1** and choose **More Operations>Mapped**.
- 2 Select Boundaries 299, 302, and 306 only.
- 3 In the **Settings** window for **Mapped**, locate the **Reduce Element Skewness** section.
- 4 Select the **Adjust edge mesh** check box.

Distribution 1

- 1 Right-click **Mapped 5** and choose **Distribution**.
- 2 Select Edges 517 and 528 only.
- 3 In the **Settings** window for **Distribution**, locate the **Distribution** section.
- 4 From the **Distribution type** list, choose **Predefined**.

- 5 In the **Number of elements** text field, type 24.
- 6 In the **Element ratio** text field, type 2.5.
- 7 Select the **Symmetric distribution** check box.

Distribution 2

- 1 In the **Model Builder** window, right-click **Mapped 5** and choose **Distribution**.
- 2 Select Edge 563 only.
- 3 In the **Settings** window for **Distribution**, locate the **Distribution** section.
- 4 From the **Distribution type** list, choose **Predefined**.
- 5 In the **Number of elements** text field, type 26.
- 6 In the **Element ratio** text field, type 9.
- 7 Select the **Symmetric distribution** check box.

Swept 2

- 1 In the **Model Builder** window, right-click **Mesh 1** and choose **Swept**.
- 2 In the **Settings** window for **Swept**, locate the **Domain Selection** section.
- 3 From the **Geometric entity level** list, choose **Domain**.
- 4 Select Domain 44 only.

Distribution 1

- 1 Right-click **Swept 2** and choose **Distribution**.
- 2 In the **Settings** window for **Distribution**, locate the **Distribution** section.
- 3 In the **Number of elements** text field, type 4.

Copy Domain 2

- 1 In the **Model Builder** window, right-click **Mesh 1** and choose **More Operations> Copy Domain**.
- 2 Select Domain 44 only.
- 3 In the **Settings** window for **Copy Domain**, locate the **Destination Domains** section.
- 4 Select the **Activate Selection** toggle button.
- 5 Select Domains 37 and 39 only.

Swept 3

- 1 Right-click **Mesh 1** and choose **Swept**.
- 2 In the **Settings** window for **Swept**, locate the **Domain Selection** section.
- 3 From the **Geometric entity level** list, choose **Domain**.

4 Select Domains 26 and 46 only.

Distribution 1

- 1 Right-click **Swept 3** and choose **Distribution**.
- 2 In the **Settings** window for **Distribution**, locate the **Domain Selection** section.
- 3 In the list, select **46**.
- 4 Click  **Remove from Selection**.
- 5 Select Domain 26 only.
- 6 Locate the **Distribution** section. From the **Distribution type** list, choose **Predefined**.
- 7 In the **Number of elements** text field, type 6.
- 8 In the **Element ratio** text field, type 2.
- 9 Select the **Symmetric distribution** check box.

Copy Domain 3

- 1 In the **Model Builder** window, right-click **Mesh 1** and choose **More Operations>Copy Domain**.
- 2 Select Domains 26 and 46 only.
- 3 In the **Settings** window for **Copy Domain**, locate the **Destination Domains** section.
- 4 Select the  **Activate Selection** toggle button.
- 5 Select Domain 28 only.

Copy Domain 4

- 1 Right-click **Mesh 1** and choose **More Operations>Copy Domain**.
- 2 Select Domains 26 and 46 only.
- 3 In the **Settings** window for **Copy Domain**, locate the **Destination Domains** section.
- 4 Select the  **Activate Selection** toggle button.
- 5 Select Domains 10 and 41 only.

Copy Domain 5

- 1 Right-click **Mesh 1** and choose **More Operations>Copy Domain**.
- 2 Select Domains 10 and 41 only.
- 3 In the **Settings** window for **Copy Domain**, locate the **Destination Domains** section.
- 4 Select the  **Activate Selection** toggle button.
- 5 Select Domains 7 and 38 only.

Mapped 6

- 1 Right-click **Mesh 1** and choose **More Operations>Mapped**.
- 2 Select Boundary 104 only.

Distribution 1

- 1 Right-click **Mapped 6** and choose **Distribution**.
- 2 Select Edge 148 only.
- 3 In the **Settings** window for **Distribution**, locate the **Distribution** section.
- 4 In the **Number of elements** text field, type 3.

Mapped 7

- 1 In the **Model Builder** window, right-click **Mesh 1** and choose **More Operations>Mapped**.
- 2 Select Boundary 209 only.

Distribution 1

- 1 Right-click **Mapped 7** and choose **Distribution**.
- 2 Select Edge 360 only.
- 3 In the **Settings** window for **Distribution**, locate the **Distribution** section.
- 4 In the **Number of elements** text field, type 6.

Swept 4

- 1 In the **Model Builder** window, right-click **Mesh 1** and choose **Swept**.
- 2 In the **Settings** window for **Swept**, locate the **Domain Selection** section.
- 3 From the **Geometric entity level** list, choose **Domain**.
- 4 Select Domains 23 and 43 only.

Distribution 1

- 1 Right-click **Swept 4** and choose **Distribution**.

Mapped 8

- 1 In the **Model Builder** window, right-click **Mesh 1** and choose **More Operations>Mapped**.
- 2 Select Boundary 112 only.

Distribution 1

- 1 Right-click **Mapped 8** and choose **Distribution**.
- 2 Select Edges 153 and 508 only.
- 3 In the **Settings** window for **Distribution**, locate the **Distribution** section.
- 4 From the **Distribution type** list, choose **Predefined**.

- 5 In the **Number of elements** text field, type 7.
- 6 In the **Element ratio** text field, type 2.
- 7 Select the **Symmetric distribution** check box.

Swept 5

- 1 In the **Model Builder** window, right-click **Mesh 1** and choose **Swept**.
- 2 In the **Settings** window for **Swept**, locate the **Domain Selection** section.
- 3 From the **Geometric entity level** list, choose **Domain**.
- 4 Select Domains 24, 25, and 27 only.

Distribution 1

- 1 Right-click **Swept 5** and choose **Distribution**.
- 2 In the **Settings** window for **Distribution**, locate the **Distribution** section.
- 3 In the **Number of elements** text field, type 2.

Mapped 9

- 1 In the **Model Builder** window, right-click **Mesh 1** and choose **More Operations>Mapped**.
- 2 Select Boundaries 54, 190, and 197 only.

Distribution 1

- 1 Right-click **Mapped 9** and choose **Distribution**.
- 2 Select Edges 312 and 314 only.
- 3 In the **Settings** window for **Distribution**, locate the **Distribution** section.
- 4 In the **Number of elements** text field, type 2.

Distribution 2

- 1 In the **Model Builder** window, right-click **Mapped 9** and choose **Distribution**.
- 2 Select Edges 76 and 78 only.
- 3 In the **Settings** window for **Distribution**, locate the **Distribution** section.
- 4 From the **Distribution type** list, choose **Predefined**.
- 5 In the **Number of elements** text field, type 16.
- 6 In the **Element ratio** text field, type 3.
- 7 From the **Growth formula** list, choose **Geometric sequence**.
- 8 Select the **Reverse direction** check box.

Distribution 3

- 1 Right-click **Mapped 9** and choose **Distribution**.

- 2 Select Edges 327 and 329 only.
- 3 In the **Settings** window for **Distribution**, locate the **Distribution** section.
- 4 From the **Distribution type** list, choose **Predefined**.
- 5 In the **Number of elements** text field, type 19.
- 6 In the **Element ratio** text field, type 2.5.
- 7 From the **Growth formula** list, choose **Geometric sequence**.

Distribution 4

- 1 Right-click **Mapped 9** and choose **Distribution**.
- 2 Select Edge 75 only.
- 3 In the **Settings** window for **Distribution**, locate the **Distribution** section.
- 4 In the **Number of elements** text field, type 3.

Swept 6

- 1 In the **Model Builder** window, right-click **Mesh 1** and choose **Swept**.
- 2 In the **Settings** window for **Swept**, locate the **Domain Selection** section.
- 3 From the **Geometric entity level** list, choose **Domain**.
- 4 Select Domain 11 only.
- 5 Click to expand the **Source Faces** section. Select Boundaries 54, 190, and 197 only.
- 6 Click to expand the **Destination Faces** section. Select Boundary 49 only.

Distribution 1

- 1 Right-click **Swept 6** and choose **Distribution**.
- 2 In the **Settings** window for **Distribution**, locate the **Distribution** section.
- 3 In the **Number of elements** text field, type 2.

Copy Domain 6

- 1 In the **Model Builder** window, right-click **Mesh 1** and choose **More Operations> Copy Domain**.
- 2 Select Domain 11 only.
- 3 In the **Settings** window for **Copy Domain**, locate the **Destination Domains** section.
- 4 Select the **Activate Selection** toggle button.
- 5 Select Domain 8 only.

Swept 7

- 1 Right-click **Mesh 1** and choose **Swept**.

- 2 In the **Settings** window for **Swept**, locate the **Domain Selection** section.
- 3 From the **Geometric entity level** list, choose **Domain**.
- 4 Select Domains 40, 42, 45, and 47 only.

Distribution 1

- 1 Right-click **Swept 7** and choose **Distribution**.
- 2 In the **Settings** window for **Distribution**, locate the **Distribution** section.
- 3 In the **Number of elements** text field, type 2.

Mapped 10

- 1 In the **Model Builder** window, right-click **Mesh 1** and choose **More Operations>Mapped**.
- 2 Select Boundaries 43, 188, and 196 only.

Distribution 1

- 1 Right-click **Mapped 10** and choose **Distribution**.
- 2 Select Edges 62, 307, 323, and 479 only.
- 3 In the **Settings** window for **Distribution**, locate the **Distribution** section.
- 4 From the **Distribution type** list, choose **Predefined**.
- 5 In the **Number of elements** text field, type 7.
- 6 In the **Element ratio** text field, type 2.
- 7 Select the **Symmetric distribution** check box.

Swept 8

- 1 In the **Model Builder** window, right-click **Mesh 1** and choose **Swept**.
- 2 In the **Settings** window for **Swept**, locate the **Domain Selection** section.
- 3 From the **Geometric entity level** list, choose **Domain**.
- 4 Select Domain 9 only.

Distribution 1

- 1 Right-click **Swept 8** and choose **Distribution**.
- 2 In the **Settings** window for **Distribution**, locate the **Distribution** section.
- 3 In the **Number of elements** text field, type 2.

Free Triangular 1

- 1 In the **Model Builder** window, right-click **Mesh 1** and choose **More Operations>Free Triangular**.
- 2 Select Boundary 213 only.

Distribution 1

- 1 Right-click **Free Triangular 1** and choose **Distribution**.
- 2 Select Edges 372 and 373 only.
- 3 In the **Settings** window for **Distribution**, locate the **Distribution** section.
- 4 In the **Number of elements** text field, type 12.

Mapped 11

- 1 In the **Model Builder** window, right-click **Mesh 1** and choose **More Operations>Mapped**.
- 2 Select Boundaries 71 and 98 only.

Distribution 1

- 1 Right-click **Mapped 11** and choose **Distribution**.
- 2 Select Edges 133 and 143 only.
- 3 In the **Settings** window for **Distribution**, locate the **Distribution** section.
- 4 In the **Number of elements** text field, type 3.

Distribution 2

- 1 In the **Model Builder** window, right-click **Mapped 11** and choose **Distribution**.
- 2 Select Edges 95 and 107 only.
- 3 In the **Settings** window for **Distribution**, locate the **Distribution** section.
- 4 In the **Number of elements** text field, type 6.

Free Triangular 2

- 1 In the **Model Builder** window, right-click **Mesh 1** and choose **More Operations>Free Triangular**.
- 2 Select Boundary 77 only.

Free Quad 1

- 1 Right-click **Mesh 1** and choose **More Operations>Free Quad**.
- 2 Select Boundary 55 only.

Size 1

- 1 Right-click **Free Quad 1** and choose **Size**.
- 2 In the **Settings** window for **Size**, locate the **Element Size** section.
- 3 Click the **Custom** button.
- 4 Locate the **Element Size Parameters** section. Select the **Maximum element size** check box.
- 5 In the associated text field, type 0.05.

Distribution 1

- 1 In the **Model Builder** window, right-click **Free Quad 1** and choose **Distribution**.
- 2 Select Edge 493 only.
- 3 In the **Settings** window for **Distribution**, locate the **Distribution** section.
- 4 From the **Distribution type** list, choose **Predefined**.
- 5 In the **Number of elements** text field, type 32.
- 6 In the **Element ratio** text field, type 3.5.
- 7 Select the **Symmetric distribution** check box.

Distribution 2

- 1 Right-click **Free Quad 1** and choose **Distribution**.
- 2 Select Edge 333 only.
- 3 In the **Settings** window for **Distribution**, locate the **Distribution** section.
- 4 From the **Distribution type** list, choose **Predefined**.
- 5 In the **Number of elements** text field, type 28.
- 6 In the **Element ratio** text field, type 3.

Distribution 3

- 1 Right-click **Free Quad 1** and choose **Distribution**.
- 2 Select Edges 77 and 142 only.
- 3 In the **Settings** window for **Distribution**, locate the **Distribution** section.
- 4 From the **Distribution type** list, choose **Predefined**.
- 5 In the **Number of elements** text field, type 16.
- 6 In the **Element ratio** text field, type 3.
- 7 Select the **Symmetric distribution** check box.

Distribution 4

- 1 Right-click **Free Quad 1** and choose **Distribution**.
- 2 Select Edges 277 and 333 only.
- 3 In the **Settings** window for **Distribution**, locate the **Distribution** section.
- 4 From the **Distribution type** list, choose **Predefined**.
- 5 In the **Number of elements** text field, type 28.
- 6 In the **Element ratio** text field, type 3.
- 7 Select the **Reverse direction** check box.

Swept 9

- 1 In the **Model Builder** window, right-click **Mesh 1** and choose **Swept**.
- 2 In the **Settings** window for **Swept**, locate the **Domain Selection** section.
- 3 From the **Geometric entity level** list, choose **Domain**.
- 4 Select Domain 12 only.

Distribution 1

Right-click **Swept 9** and choose **Distribution**.

Swept 10

- 1 In the **Model Builder** window, right-click **Mesh 1** and choose **Swept**.
- 2 In the **Settings** window for **Swept**, locate the **Domain Selection** section.
- 3 From the **Geometric entity level** list, choose **Domain**.
- 4 Select Domain 34 only.

Distribution 1

- 1 Right-click **Swept 10** and choose **Distribution**.
- 2 In the **Settings** window for **Distribution**, locate the **Distribution** section.
- 3 From the **Distribution type** list, choose **Predefined**.
- 4 In the **Number of elements** text field, type 60.
- 5 In the **Element ratio** text field, type 3.
- 6 Select the **Symmetric distribution** check box.

Swept 11

- 1 In the **Model Builder** window, right-click **Mesh 1** and choose **Swept**.
- 2 In the **Settings** window for **Swept**, locate the **Domain Selection** section.
- 3 From the **Geometric entity level** list, choose **Domain**.
- 4 Select Domains 17 and 22 only.

Distribution 1

- 1 Right-click **Swept 11** and choose **Distribution**.
- 2 In the **Settings** window for **Distribution**, locate the **Distribution** section.
- 3 In the **Number of elements** text field, type 8.

Mapped 12

- 1 In the **Model Builder** window, right-click **Mesh 1** and choose **More Operations>Mapped**.
- 2 Select Boundary 9 only.

Distribution 1

- 1 Right-click **Mapped 12** and choose **Distribution**.
- 2 Select Edge 11 only.
- 3 In the **Settings** window for **Distribution**, locate the **Distribution** section.
- 4 In the **Number of elements** text field, type 3.

Mapped 13

- 1 In the **Model Builder** window, right-click **Mesh 1** and choose **More Operations>Mapped**.
- 2 Select Boundary 202 only.

Distribution 1

- 1 Right-click **Mapped 13** and choose **Distribution**.
- 2 Select Edge 341 only.
- 3 In the **Settings** window for **Distribution**, locate the **Distribution** section.
- 4 In the **Number of elements** text field, type 6.

Mapped 14

- 1 In the **Model Builder** window, right-click **Mesh 1** and choose **More Operations>Mapped**.
- 2 Select Boundaries 13 and 149 only.

Distribution 1

- 1 Right-click **Mapped 14** and choose **Distribution**.
- 2 Select Edge 16 only.
- 3 In the **Settings** window for **Distribution**, locate the **Distribution** section.
- 4 In the **Number of elements** text field, type 3.

Distribution 2

- 1 In the **Model Builder** window, right-click **Mapped 14** and choose **Distribution**.
- 2 Select Edge 14 only.
- 3 In the **Settings** window for **Distribution**, locate the **Distribution** section.
- 4 In the **Number of elements** text field, type 3.

Distribution 3

- 1 Right-click **Mapped 14** and choose **Distribution**.
- 2 Select Edge 225 only.
- 3 In the **Settings** window for **Distribution**, locate the **Distribution** section.
- 4 In the **Number of elements** text field, type 2.

Mapped 15

- 1 In the **Model Builder** window, right-click **Mesh 1** and choose **More Operations>Mapped**.
- 2 Select Boundary 170 only.

Distribution 1

- 1 Right-click **Mapped 15** and choose **Distribution**.
- 2 Select Edges 267 and 270 only.
- 3 In the **Settings** window for **Distribution**, locate the **Distribution** section.
- 4 From the **Distribution type** list, choose **Predefined**.
- 5 In the **Number of elements** text field, type 26.
- 6 In the **Element ratio** text field, type 3.
- 7 Select the **Symmetric distribution** check box.

Swept 12

- 1 In the **Model Builder** window, right-click **Mesh 1** and choose **Swept**.
- 2 In the **Settings** window for **Swept**, locate the **Domain Selection** section.
- 3 From the **Geometric entity level** list, choose **Domain**.
- 4 Select Domains 3 and 30 only.

Distribution 1

- 1 Right-click **Swept 12** and choose **Distribution**.
- 2 In the **Settings** window for **Distribution**, locate the **Distribution** section.
- 3 From the **Distribution type** list, choose **Predefined**.
- 4 In the **Number of elements** text field, type 6.
- 5 In the **Element ratio** text field, type 2.
- 6 Select the **Symmetric distribution** check box.

Swept 13

- 1 In the **Model Builder** window, right-click **Mesh 1** and choose **Swept**.
- 2 In the **Settings** window for **Swept**, locate the **Domain Selection** section.
- 3 From the **Geometric entity level** list, choose **Domain**.
- 4 Select Domain 36 only.

Swept 14

- 1 Right-click **Mesh 1** and choose **Swept**.
- 2 In the **Settings** window for **Swept**, locate the **Domain Selection** section.

3 From the **Geometric entity level** list, choose **Domain**.

4 Select Domain 4 only.

Distribution 1

1 Right-click **Swept 14** and choose **Distribution**.

2 In the **Settings** window for **Distribution**, locate the **Distribution** section.

3 In the **Number of elements** text field, type 2.

Free Triangular 3

1 In the **Model Builder** window, right-click **Mesh 1** and choose **More Operations> Free Triangular**.

2 Select Boundary 21 only.

Distribution 1

1 Right-click **Free Triangular 3** and choose **Distribution**.

2 Select Edges 26 and 33 only.

3 In the **Settings** window for **Distribution**, locate the **Distribution** section.

4 In the **Number of elements** text field, type 3.

Free Triangular 4

1 In the **Model Builder** window, right-click **Mesh 1** and choose **More Operations> Free Triangular**.

2 Select Boundary 19 only.

Size 1

1 Right-click **Free Triangular 4** and choose **Size**.

2 In the **Settings** window for **Size**, locate the **Element Size** section.

3 Click the **Custom** button.

4 Locate the **Element Size Parameters** section. Select the **Maximum element size** check box.

5 In the associated text field, type 0.02.

Swept 15

1 In the **Model Builder** window, right-click **Mesh 1** and choose **Swept**.

2 In the **Settings** window for **Swept**, locate the **Domain Selection** section.

3 From the **Geometric entity level** list, choose **Domain**.

4 Select Domain 5 only.

Free Triangular 5

- 1 Right-click **Mesh 1** and choose **More Operations>Free Triangular**.
- 2 Select Boundary 193 only.

Distribution 1

- 1 Right-click **Free Triangular 5** and choose **Distribution**.
- 2 Select Edges 318 and 319 only.

Swept 16

- 1 In the **Model Builder** window, right-click **Mesh 1** and choose **Swept**.
- 2 In the **Settings** window for **Swept**, locate the **Domain Selection** section.
- 3 From the **Geometric entity level** list, choose **Domain**.
- 4 Select Domain 6 only.

Distribution 1

- 1 Right-click **Swept 16** and choose **Distribution**.
- 2 In the **Settings** window for **Distribution**, locate the **Distribution** section.
- 3 From the **Distribution type** list, choose **Predefined**.
- 4 In the **Number of elements** text field, type 15.
- 5 In the **Element ratio** text field, type 2.
- 6 Select the **Symmetric distribution** check box.

Free Tetrahedral 1

- 1 In the **Model Builder** window, right-click **Mesh 1** and choose **Free Tetrahedral**.
- 2 In the **Settings** window for **Free Tetrahedral**, locate the **Domain Selection** section.
- 3 From the **Geometric entity level** list, choose **Domain**.
- 4 Select Domain 35 only.

Size 1

- 1 Right-click **Free Tetrahedral 1** and choose **Size**.
- 2 In the **Settings** window for **Size**, locate the **Element Size** section.
- 3 Click the **Custom** button.
- 4 Locate the **Element Size Parameters** section. Select the **Maximum element size** check box.
- 5 In the associated text field, type 0.033.

Swept 17

- 1 In the **Model Builder** window, right-click **Mesh 1** and choose **Swept**.

- 2 In the **Settings** window for **Swept**, locate the **Domain Selection** section.
- 3 From the **Geometric entity level** list, choose **Domain**.
- 4 Select Domain 33 only.

Distribution 1

- 1 Right-click **Swept 17** and choose **Distribution**.
- 2 In the **Settings** window for **Distribution**, locate the **Distribution** section.
- 3 From the **Distribution type** list, choose **Predefined**.
- 4 In the **Number of elements** text field, type 40.
- 5 In the **Element ratio** text field, type 3.
- 6 Select the **Symmetric distribution** check box.

Swept 18

- 1 In the **Model Builder** window, right-click **Mesh 1** and choose **Swept**.
- 2 In the **Settings** window for **Swept**, locate the **Domain Selection** section.
- 3 From the **Geometric entity level** list, choose **Domain**.
- 4 Select Domain 16 only.

Free Tetrahedral 2

- 1 Right-click **Mesh 1** and choose **Free Tetrahedral**.
- 2 In the **Settings** window for **Free Tetrahedral**, locate the **Domain Selection** section.
- 3 From the **Geometric entity level** list, choose **Domain**.
- 4 Select Domain 20 only.

Swept 19

- 1 Right-click **Mesh 1** and choose **Swept**.
- 2 In the **Settings** window for **Swept**, locate the **Domain Selection** section.
- 3 From the **Geometric entity level** list, choose **Domain**.
- 4 Select Domains 15 and 19 only.

Distribution 1

- 1 Right-click **Swept 19** and choose **Distribution**.
- 2 In the **Settings** window for **Distribution**, locate the **Distribution** section.
- 3 From the **Distribution type** list, choose **Predefined**.
- 4 In the **Number of elements** text field, type 20.
- 5 In the **Element ratio** text field, type 4.

6 Select the **Symmetric distribution** check box.

Swept 20

- 1** In the **Model Builder** window, right-click **Mesh 1** and choose **Swept**.
- 2** In the **Settings** window for **Swept**, locate the **Domain Selection** section.
- 3** From the **Geometric entity level** list, choose **Domain**.
- 4** Select Domain 14 only.

Distribution 1

- 1** Right-click **Swept 20** and choose **Distribution**.
- 2** In the **Settings** window for **Distribution**, locate the **Distribution** section.
- 3** In the **Number of elements** text field, type 2.

Mapped 16

- 1** In the **Model Builder** window, right-click **Mesh 1** and choose **More Operations>Mapped**.
- 2** Select Boundaries 58 and 93 only.

Distribution 1

- 1** Right-click **Mapped 16** and choose **Distribution**.
- 2** Select Edges 81 and 97 only.
- 3** In the **Settings** window for **Distribution**, locate the **Distribution** section.
- 4** In the **Number of elements** text field, type 6.

Distribution 2

- 1** In the **Model Builder** window, right-click **Mapped 16** and choose **Distribution**.
- 2** Select Edges 126 and 136 only.
- 3** In the **Settings** window for **Distribution**, locate the **Distribution** section.
- 4** In the **Number of elements** text field, type 3.

Swept 21

- 1** In the **Model Builder** window, right-click **Mesh 1** and choose **Swept**.
- 2** In the **Settings** window for **Swept**, locate the **Domain Selection** section.
- 3** From the **Geometric entity level** list, choose **Domain**.
- 4** Select Domains 13 and 21 only.

Distribution 1

- 1** Right-click **Swept 21** and choose **Distribution**.
- 2** In the **Settings** window for **Distribution**, locate the **Distribution** section.

- 3 From the **Distribution type** list, choose **Predefined**.
- 4 In the **Number of elements** text field, type 50.
- 5 In the **Element ratio** text field, type 6.
- 6 Select the **Symmetric distribution** check box.

Free Tetrahedral 3

- 1 In the **Model Builder** window, right-click **Mesh 1** and choose **Free Tetrahedral**.
- 2 In the **Settings** window for **Free Tetrahedral**, locate the **Domain Selection** section.
- 3 From the **Geometric entity level** list, choose **Domain**.
- 4 Select Domain 18 only.

Free Triangular 6

- 1 Right-click **Mesh 1** and choose **More Operations>Free Triangular**.
- 2 Select Boundary 28 only.

Size 1

- 1 Right-click **Free Triangular 6** and choose **Size**.
- 2 In the **Settings** window for **Size**, locate the **Element Size** section.
- 3 From the **Calibrate for** list, choose **Fluid dynamics**.
- 4 Click the **Custom** button.
- 5 Locate the **Element Size Parameters** section. Select the **Maximum element size** check box.
- 6 In the associated text field, type 0.05.
- 7 Select the **Minimum element size** check box.
- 8 In the associated text field, type 0.015.

Distribution 1

- 1 In the **Model Builder** window, right-click **Free Triangular 6** and choose **Distribution**.
- 2 Select Edges 40 and 48 only.
- 3 In the **Settings** window for **Distribution**, locate the **Distribution** section.
- 4 In the **Number of elements** text field, type 60.

Mapped 17

- 1 In the **Model Builder** window, right-click **Mesh 1** and choose **More Operations>Mapped**.
- 2 Select Boundaries 23, 24, 27, and 30 only.

Distribution 1

- 1 Right-click **Mapped 17** and choose **Distribution**.

- 2 Select Edge 193 only.
- 3 In the **Settings** window for **Distribution**, locate the **Distribution** section.
- 4 In the **Number of elements** text field, type 6.

Distribution 2

- 1 In the **Model Builder** window, right-click **Mapped 17** and choose **Distribution**.
- 2 Select Edges 184 and 186 only.

Distribution 3

- 1 Right-click **Mapped 17** and choose **Distribution**.
- 2 Select Edges 29 and 187 only.
- 3 In the **Settings** window for **Distribution**, locate the **Distribution** section.
- 4 In the **Number of elements** text field, type 7.

Mapped 17

- 1 Right-click **Mapped 17** and choose **Build Selected**.
- 2 Click the  **Wireframe Rendering** button in the **Graphics** toolbar.

The mesh should at this point look like the figure below. All the solid parts are now meshed and only volume mesh for the fluid domains remains.

Size 1

1 In the **Model Builder** window, right-click **Mesh 1** and choose **Size**.

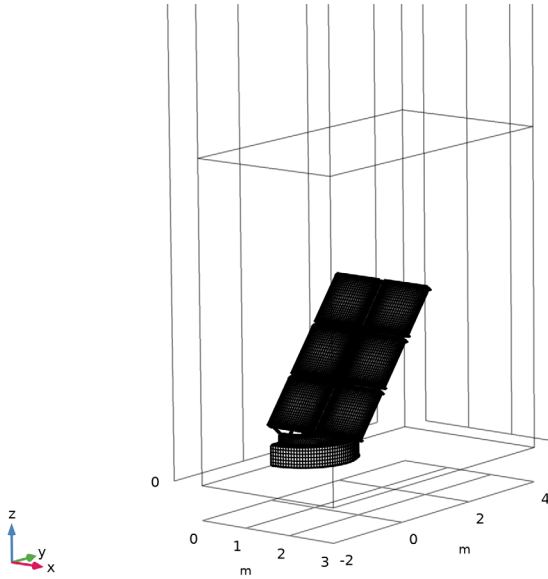

- 2 In the **Settings** window for **Size**, locate the **Geometric Entity Selection** section.
- 3 From the **Geometric entity level** list, choose **Boundary**.
- 4 Select Boundaries 3 and 74 only.
- 5 Locate the **Element Size** section. Click the **Custom** button.
- 6 Locate the **Element Size Parameters** section. Select the **Maximum element size** check box.
- 7 In the associated text field, type 0.15.

Free Tetrahedral 4

- 1 Right-click **Mesh 1** and choose **Free Tetrahedral**.
- 2 In the **Settings** window for **Free Tetrahedral**, locate the **Domain Selection** section.
- 3 From the **Geometric entity level** list, choose **Domain**.
- 4 Select Domain 1 only.
- 5 Click to expand the **Element Quality Optimization** section. From the **Optimization level** list, choose **High**.

Boundary Layers 1

- 1 In the **Model Builder** window, click **Boundary Layers 1**.

- 2 In the **Settings** window for **Boundary Layers**, locate the **Domain Selection** section.
- 3 In the list, select **2**.
- 4 Click  **Remove from Selection**.
- 5 Select Domain 1 only.
- 6 Click to expand the **Corner Settings** section. In the **Minimum angle for trimming** text field, type 280.

Boundary Layer Properties 1

- 1 In the **Model Builder** window, expand the **Boundary Layers 1** node, then click **Boundary Layer Properties 1**.
- 2 In the **Settings** window for **Boundary Layer Properties**, locate the **Boundary Selection** section.
- 3 From the **Selection** list, choose **Walls**.
- 4 Locate the **Boundary Layer Properties** section. In the **Thickness adjustment factor** text field, type 1.5.
- 5 In the **Number of boundary layers** text field, type 7.

Boundary Layers 1

In the **Model Builder** window, right-click **Boundary Layers 1** and choose **Build Selected**.

Swept 22

- 1 In the **Model Builder** window, right-click **Mesh 1** and choose **Swept**.
- 2 In the **Settings** window for **Swept**, locate the **Domain Selection** section.
- 3 From the **Geometric entity level** list, choose **Domain**.
- 4 Select Domain 2 only.

Distribution 1

- 1 Right-click **Swept 22** and choose **Distribution**.
- 2 In the **Settings** window for **Distribution**, locate the **Distribution** section.
- 3 From the **Distribution type** list, choose **Predefined**.
- 4 In the **Number of elements** text field, type 25.
- 5 In the **Element ratio** text field, type 5.
- 6 Click  **Build All**.

