



Absorptive Muffler

Introduction

This example describes the pressure-wave propagation in a muffler for an internal combustion engine. The approach used here is generally applicable to analyzing the damping of propagating pressure waves as well as determining the transmission properties of a given system. The model uses the port boundary conditions to model the inlet and outlet of the muffler. The model shows how to analyze both inductive and resistive damping in pressure acoustics. The main output is the transmission loss for the frequency range 50 Hz–1500 Hz. It is represented both as a continuous curve and given in 1/3 octave bands.

See also the application [Eigenmodes in a Muffler](#), which computes the propagating modes in the main chamber of the muffler.

Model Definition

The muffler—schematically shown in [Figure 1](#)—consists of a 24-liter resonator chamber with a section of the centered exhaust pipe included at each end. The model is first set up assuming that the chamber is empty. Secondly, it is lined with 15 mm of absorbing glass wool.

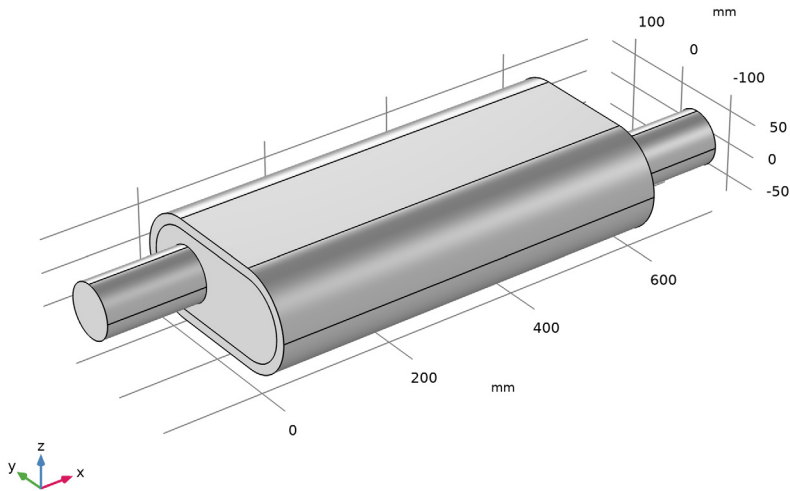

Figure 1: Geometry of the lined muffler; the liner is the outer layer in the main muffler volume. The exhaust fumes enter through the left pipe and exit through the right pipe.

DOMAIN EQUATIONS

This model solves the problem in the frequency domain using the Pressure Acoustics, Frequency Domain interface. The model equation is a slightly modified version of the Helmholtz equation

$$\nabla \cdot \left(-\frac{\nabla p}{\rho} \right) - \frac{\omega^2 p}{c^2 \rho} = 0$$

where p is the acoustic pressure, ρ is the density, c is the speed of sound, and ω is the angular frequency.

In the absorbing glass wool, modeled as a Poroacoustics domain, the damping enters the equation as a complex speed of sound, $c_c = \omega/k_c$, and a complex density, $\rho_c = k_c Z_c/\omega$, where k_c is the complex wave number and Z_c equals the complex impedance. This is an equivalent fluid model for the porous domain where the losses are modeled in a homogenized way.

For a highly porous material with a rigid skeleton, the well-known model of Delany and Bazley estimates these parameters as functions of frequency and flow resistivity. Using the original coefficients of Delany and Bazley (Ref. 1), the expressions are

$$k_c = k_a \cdot \left(1 + 0.098 \cdot \left(\frac{\rho_a f}{R_f} \right)^{-0.7} - i \cdot 0.189 \cdot \left(\frac{\rho_a f}{R_f} \right)^{-0.595} \right)$$
$$Z_c = Z_a \cdot \left(1 + 0.057 \cdot \left(\frac{\rho_a f}{R_f} \right)^{0.734} - i \cdot 0.087 \cdot \left(\frac{\rho_a f}{R_f} \right)^{-0.732} \right)$$

where R_f is the flow resistivity, and where $k_a = \omega/c_a$ and $Z_a = \rho_a c_a$ are the free-space wave number and characteristic impedance of air, respectively. This is the default selected porous model in the Poroacoustics domain feature. Several porous models can be selected here depending on the situation at hand. You can find flow resistivities in tables (see, for example, Ref. 3) or by measuring it. For glass-wool-like materials, Bies and Hansen (Ref. 2) give an empirical correlation

$$R_f = \frac{3.18 \cdot 10^{-9} \cdot \rho_{ap}^{1.53}}{d_{av}^2}$$

where ρ_{ap} is the apparent density of the material and d_{av} is the mean fiber diameter. This model uses a rather lightweight glass wool with $\rho_{ap} = 12 \text{ kg/m}^3$ and $d_{av} = 10 \text{ }\mu\text{m}$.

Note: The Delany-Bazley model is valid for values of $\frac{\rho_f f}{R_f}$ up to $\frac{\rho_f f}{R_f} \approx 1$, so the upper frequency limit of 1500 Hz ensures that the poroacoustics model applies. Other variants of the Delany-Bazley model are built into the Acoustics Module; these have different validity regions or are used for other fibrous materials. For example, the Miki parameters can be selected, they extend the region of applicability of the Delany-Bazley constants.

BOUNDARY CONDITIONS

- At the solid boundaries, which are the outer walls of the resonator chamber and the pipes, the model uses sound hard (wall) boundary conditions. The condition imposes that the normal velocity at the boundary is zero.
- The model uses port boundary conditions to model the inlet and outlet of the muffler. In waveguides, the port conditions are superior to radiation condition as they can capture complex wave fields that involve several propagating modes. The port uses a plane-wave (0,0) mode to excite the system. As the analysis is carried out above the cutoff frequency of the first non-plane mode (above 2514 Hz), then more port conditions at the inlet and outlet are required to capture these modes. Note that when including an azimuthal mode in a circular port, it is necessary to add both possible directions as different Port conditions (the modes are orthogonal). Note that each port condition generates a postprocessing variable that defined the cutoff frequency of its mode, for example, for **Port 2** the variable is `acpr.port2.fc`.

Results and Discussion

The pressure distribution in the absorptive muffler without the lining material is shown in [Figure 2](#) for the frequency $f = 2800$ Hz. From the figure, it is seen that at this frequency not only longitudinal standing waves exist but also transverse modes are present.

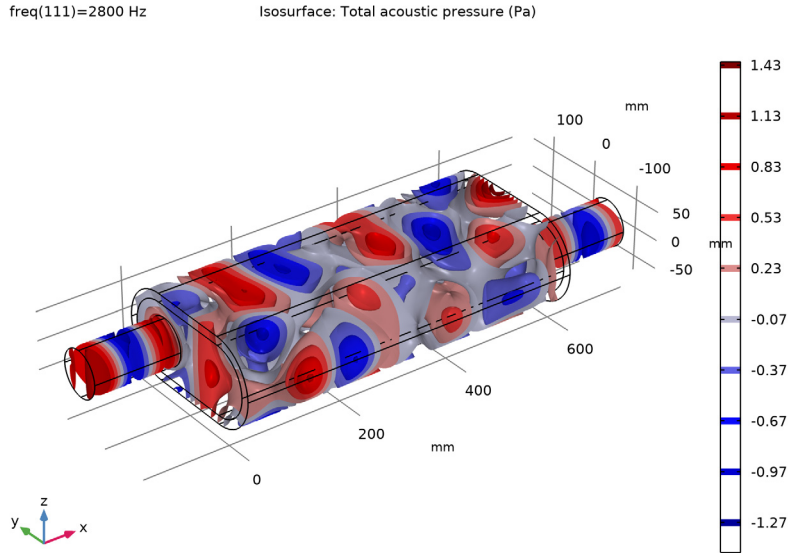

Figure 2: Pressure represented as an iso-barometric surface plot in the muffler.

An important parameter for a muffler is the transmission loss or attenuation. It is defined as the ratio between the incoming and outgoing acoustic energy. The attenuation or transmission loss L (in dB) of the acoustic energy is defined by

$$L = 10 \log \left(\frac{P_{\text{in}}}{P_{\text{out}}} \right)$$

Here P_{in} and P_{out} denote the incoming power at the inlet and the outgoing power at the outlet, respectively. These values are readily derived from the port boundary variables as `acpr.port1.P_in` and `acpr.port4.P_out`, `acpr.port5.P_out`, `acpr.port6.P_out` and can be directly used in postprocessing.

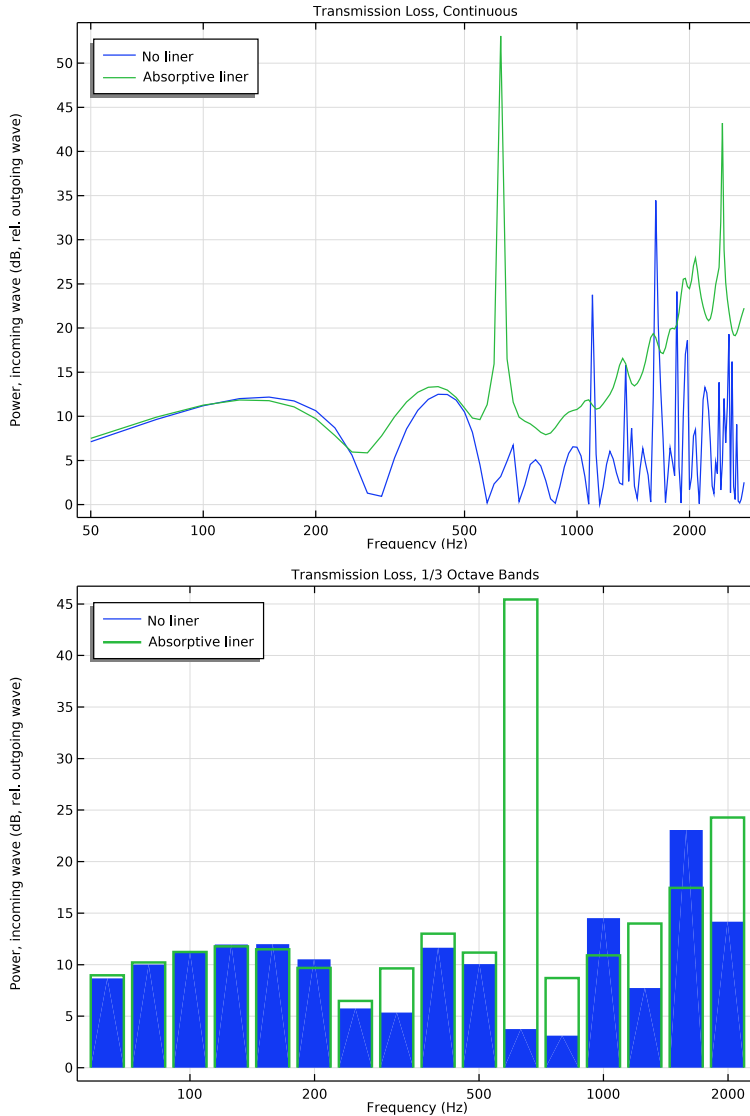

Figure 3: Comparison of the transmission loss as function of frequency for the empty muffler and the muffler with absorptive lining. (top) The transmission loss depicted as a continuous curve. The first four dips are due to longitudinal resonances. In the muffler with absorbing lining the dips are still present, but the general trend is that the higher the frequency, the better the damping. (bottom) The same data but depicted in 1/3 octave bands.

Figure 3 (top and bottom) shows the result of a parametric frequency study. The two graphs represent the case of an empty muffler without any absorbing lining material (blue lines) and the case with a layer of glass wool lining on the chamber's walls (green lines). In the top figure, the transmission loss is depicted as a continuous curve (pure tone sweep) while it is depicted in 1/3 octave bands in the bottom figure. Both graphs are created using the Octave Band plot of the Acoustics Module.

The graph for the undamped muffler shows that damping works rather well for most low frequencies. At frequencies higher than approximately 1000 Hz, the behavior is more complicated and there is generally less damping. Above this frequency a whole range of modes that are combinations of propagating mode and longitudinal modes become available, making the damping properties increasingly unpredictable. For an analysis of these modes, see the related model [Eigenmodes in a Muffler](#). The glass-wool lining improves attenuation at the resonance frequencies as well as at higher frequencies.

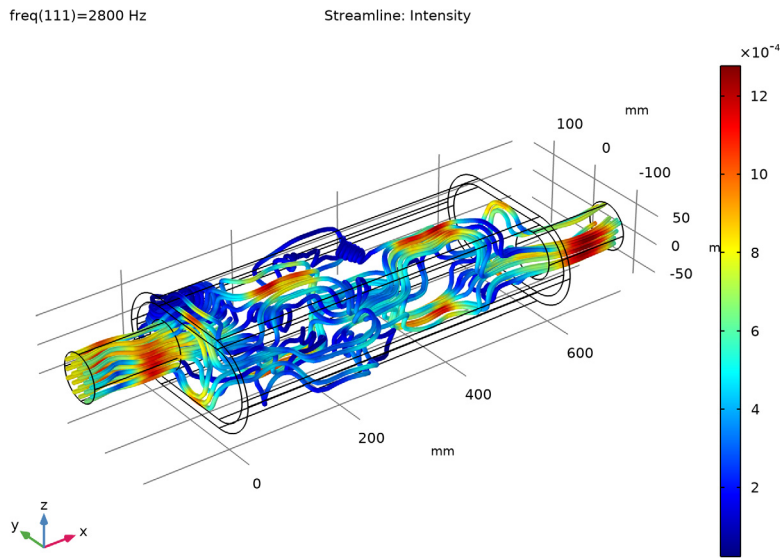

Figure 4: Intensity streamlines at 2800 Hz without the liner.

The flow of energy in the muffler without the liner is shown in Figure 4 at 2800 Hz. The plot represents the intensity field depicted as streamlines. The intensity is per definition the time average of the intensity and thus represents the average energy flow in the system.

Here from the inlet to the outlet. Change between solutions and frequencies to study and visualize the sound-absorbing properties of the muffler.

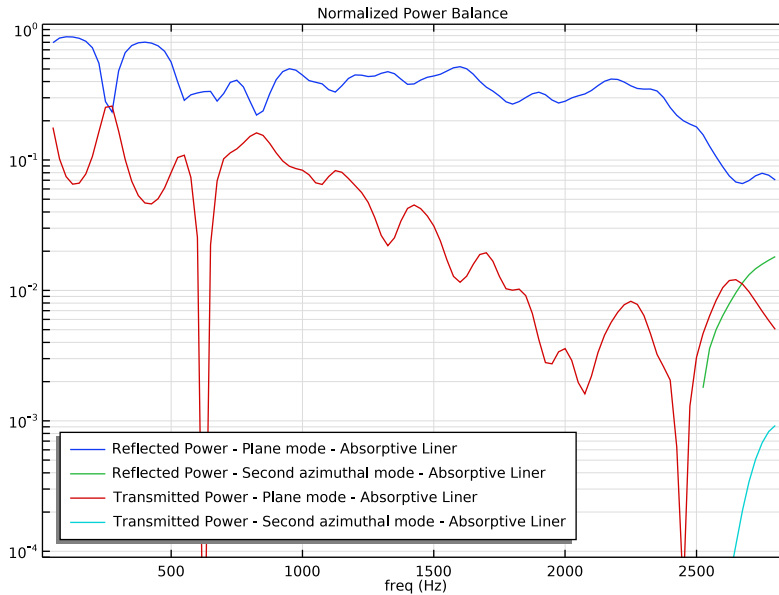

Figure 5: Normalized power balance for the muffler with absorptive lining.

The normalized power balance for the muffler with absorptive lining, shown in Figure 5, shows how plane modes are the main mechanisms for the transmitted and reflected power. Note how the azimuthal modes are only present above 2514 Hz, which is the cutoff frequency for this mode.

References

1. M.A. Delany and E.N. Bazley, "Acoustic Properties of Fibrous Absorbent Materials," *Appl. Acoust.*, vol. 3, pp. 105–116, 1970.
2. D.A. Bies and C.H. Hansen, "Flow Resistance Information for Acoustical Design," *Appl. Acoust.*, vol. 13, issue 5, Sept./Oct., pp. 357–391, 1980.
3. T.J. Cox and P.D'Antonio, *Acoustic Absorbers and Diffusers*, 2nd ed., Taylor and Francis, 2009.

Application Library path: Acoustics_Module/Automotive/absorptive_muffler

Modeling Instructions

This section contains the modeling instructions for the Absorptive Muffler model. They are followed by the [Geometry Sequence Instructions](#) section.



The instructions take you through two versions of the model, first one with a completely hollow chamber with rigid walls, then one where the chamber is lined with glass wool.

From the **File** menu, choose **New**.

NEW

In the **New** window, click  **Model Wizard**.

MODEL WIZARD

- 1 In the **Model Wizard** window, click  **3D**.
- 2 In the **Select Physics** tree, select **Acoustics>Pressure Acoustics>Pressure Acoustics, Frequency Domain (acpr)**.
- 3 Click **Add**.
- 4 Click  **Study**.
- 5 In the **Select Study** tree, select **General Studies>Frequency Domain**.
- 6 Click  **Done**.

GLOBAL DEFINITIONS

Parameters I

- 1 In the **Model Builder** window, under **Global Definitions** click **Parameters I**.
- 2 In the **Settings** window for **Parameters**, locate the **Parameters** section.
- 3 Click  **Load from File**.
- 4 Browse to the model's Application Libraries folder and double-click the file `absorptive_muffler_parameters.txt`.



The parameters define the physical values of the system.

GEOMETRY I

- 1 In the **Model Builder** window, under **Component 1 (comp1)** click **Geometry 1**.

- 2 In the **Settings** window for **Geometry**, locate the **Units** section.
- 3 From the **Length unit** list, choose **mm**.

To save some time import the geometry sequence from a file. The instructions for setting up the geometry can be found in the Geometry Sequence Instructions section at the bottom of this document.

- 4 In the **Geometry** toolbar, click  **Insert Sequence**.
- 5 Browse to the model's Application Libraries folder and double-click the file `absorptive_muffler_geom_sequence.mph`.
- 6 In the **Geometry** toolbar, click  **Build All**.

Having imported the geometry, it can be easily modified as it is parameterized. Simply change the value of a dimension in the parameters list: this will update the geometry automatically. The imported geometry parameters are automatically added to the **Parameters I** node.

The geometry should look like the one depicted in [Figure 1](#).

DEFINITIONS

Create selections for the inlet and outlet of the muffler.

Inlet

- 1 In the **Definitions** toolbar, click  **Explicit**.
- 2 In the **Settings** window for **Explicit**, type `Inlet` in the **Label** text field.
- 3 Locate the **Input Entities** section. From the **Geometric entity level** list, choose **Boundary**.
- 4 Select Boundary 1 only.

Outlet

- 1 In the **Definitions** toolbar, click  **Explicit**.
- 2 In the **Settings** window for **Explicit**, type `Outlet` in the **Label** text field.
- 3 Locate the **Input Entities** section. From the **Geometric entity level** list, choose **Boundary**.
- 4 Select Boundary 28 only.

ADD MATERIAL

- 1 In the **Home** toolbar, click  **Add Material** to open the **Add Material** window.
- 2 Go to the **Add Material** window.
- 3 In the tree, select **Built-in>Air**.
- 4 Click **Add to Component** in the window toolbar.

- 5 In the **Home** toolbar, click  **Add Material** to close the **Add Material** window.
By default, the first material you add applies on all domains so you do not need to alter the geometric scope settings.
In the second version of this model, you will use a lining material in Domain 2. Add such a material with an empty selection.

MATERIALS

Absorptive Liner

- 1 In the **Model Builder** window, under **Component 1 (comp1)** right-click **Materials** and choose **Blank Material**.
- 2 In the **Settings** window for **Material**, type Absorptive Liner in the **Label** text field.

PRESSURE ACOUSTICS, FREQUENCY DOMAIN (ACPR)

Pressure Acoustics 1



- 1 In the **Model Builder** window, under **Component 1 (comp1)**>**Pressure Acoustics, Frequency Domain (acpr)** click **Pressure Acoustics 1**.
- 2 In the **Settings** window for **Pressure Acoustics**, locate the **Model Input** section.
- 3 In the T text field, type T_0 .
- 4 In the p_A text field, type p_0 .

Use the **Port** boundary condition to define the inlet and outlet. The port condition is superior to the classical radiation condition in waveguide configurations. This is particularly the case when non-plane modes start to propagate. This happens above the first cutoff frequency. For the present model, the cutoff frequency for the first non-plane mode ($m = 1$ and $n = 0$) is at 2514 Hz so this mode should be included. Note that when including an azimuthal mode in a circular port, it is necessary to add both possible directions as different **Port** conditions (the modes are orthogonal). Note that the variable `acpr.port2.fc` gives the cutoff frequency of the mode (here for the mode defined on the **Port 2** condition).

Port 1

- 1 In the **Physics** toolbar, click  **Boundaries** and choose **Port**.
- 2 In the **Settings** window for **Port**, locate the **Boundary Selection** section.
- 3 From the **Selection** list, choose **Inlet**.
- 4 Locate the **Port Properties** section. From the **Type of port** list, choose **Circular**.
- 5 Locate the **Incident Mode Settings** section. In the A^{in} text field, type p_{in} .

Circular Port Reference Axis 1

- 1 In the **Physics** toolbar, click  **Attributes** and choose **Circular Port Reference Axis**.
- 2 In the **Settings** window for **Circular Port Reference Axis**, locate the **Point Selection** section.
- 3 Click  **Clear Selection**.
- 4 Select Points 1 and 4 only.

Select two points that define a reference axis for the azimuthal angle. The setting is in general necessary when higher order azimuthal modes are used and/or necessary.

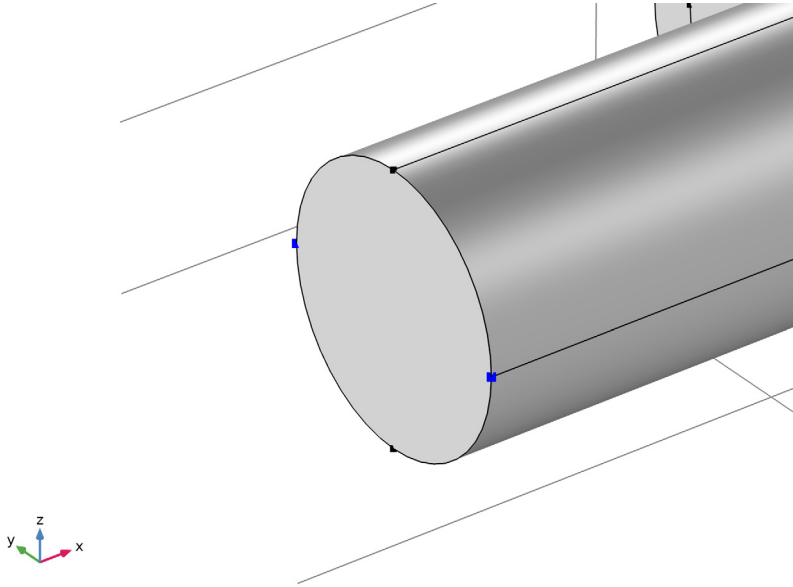

Port 2

- 1 In the **Model Builder** window, under **Component 1 (comp1)>Pressure Acoustics, Frequency Domain (acpr)** right-click **Port 1** and choose **Duplicate**.
- 2 In the **Settings** window for **Port**, locate the **Port Mode Settings** section.
- 3 In the m text field, type 1.
- 4 Locate the **Incident Mode Settings** section. From the **Incident wave excitation at this port** list, choose **Off**.

Port 3

Right-click **Port 2** and choose **Duplicate**.

Circular Port Reference Axis 1

- 1 In the **Model Builder** window, expand the **Port 3** node, then click **Circular Port Reference Axis 1**.
- 2 In the **Settings** window for **Circular Port Reference Axis**, locate the **Point Selection** section.
- 3 Click  **Clear Selection**.
- 4 Select Points 2 and 3 only.

Port 1, Port 2, Port 3

- 1 In the **Model Builder** window, under **Component 1 (comp1)>Pressure Acoustics, Frequency Domain (acpr)**, Ctrl-click to select **Port 1**, **Port 2**, and **Port 3**.
- 2 Right-click and choose **Group**.



Inlet Ports

In the **Settings** window for **Group**, type Inlet Ports in the **Label** text field.

Port 4

- 1 In the **Physics** toolbar, click  **Boundaries** and choose **Port**.
- 2 In the **Settings** window for **Port**, locate the **Boundary Selection** section.
- 3 From the **Selection** list, choose **Outlet**.
- 4 Locate the **Port Properties** section. From the **Type of port** list, choose **Circular**.

Circular Port Reference Axis 1

- 1 In the **Physics** toolbar, click  **Attributes** and choose **Circular Port Reference Axis**.
- 2 In the **Settings** window for **Circular Port Reference Axis**, locate the **Point Selection** section.
- 3 Click  **Clear Selection**.
Select two points at the outlet in the same way.
- 4 Select Points 37 and 40 only.

Port 5

- 1 In the **Model Builder** window, under **Component 1 (comp1)>Pressure Acoustics, Frequency Domain (acpr)** right-click **Port 4** and choose **Duplicate**.
- 2 In the **Settings** window for **Port**, locate the **Port Mode Settings** section.
- 3 In the *m* text field, type 1.

Port 6

Right-click **Port 5** and choose **Duplicate**.

Circular Port Reference Axis 1

- 1 In the **Model Builder** window, expand the **Port 6** node, then click **Circular Port Reference Axis 1**.
- 2 In the **Settings** window for **Circular Port Reference Axis**, locate the **Point Selection** section.
- 3 Click  **Clear Selection**.
- 4 Select Points 38 and 39 only.

Port 4, Port 5, Port 6

- 1 In the **Model Builder** window, under **Component 1 (comp1)>Pressure Acoustics, Frequency Domain (acpr)**, Ctrl-click to select **Port 4**, **Port 5**, and **Port 6**.
- 2 Right-click and choose **Group**.

Outlet Ports

- 1 In the **Settings** window for **Group**, type Outlet Ports in the **Label** text field.
Now, add a poroacoustics model for the absorptive liner domain. You will deactivate this domain when configuring the first study step.

Poroacoustics 1

- 1 In the **Physics** toolbar, click  **Domains** and choose **Poroacoustics**.
- 2 Select Domain 2 only.
- 3 In the **Settings** window for **Poroacoustics**, locate the **Model Input** section.
- 4 In the T text field, type T0.
- 5 Locate the **Porous Matrix Properties** section. From the **Porous elastic material** list, choose **Absorptive Liner (mat2)**.

The material data for the flow resistivity will now be picked up from the Absorptive Liner material. Enter the data in the material.

MATERIALS

Absorptive Liner (mat2)

- 1 In the **Model Builder** window, under **Component 1 (comp1)>Materials** click **Absorptive Liner (mat2)**.
- 2 In the **Settings** window for **Material**, locate the **Material Contents** section.
- 3 In the table, enter the following settings:

Property	Variable	Value	Unit	Property group
Flow resistivity	Rf	R_f	Pa·s/m ²	Poroacoustics model

MESH 1

- 1 In the **Model Builder** window, under **Component 1 (comp1)** click **Mesh 1**.
- 2 In the **Settings** window for **Mesh**, locate the **Mesh Settings** section.
- 3 From the **Sequence type** list, choose **User-controlled mesh**.

Size

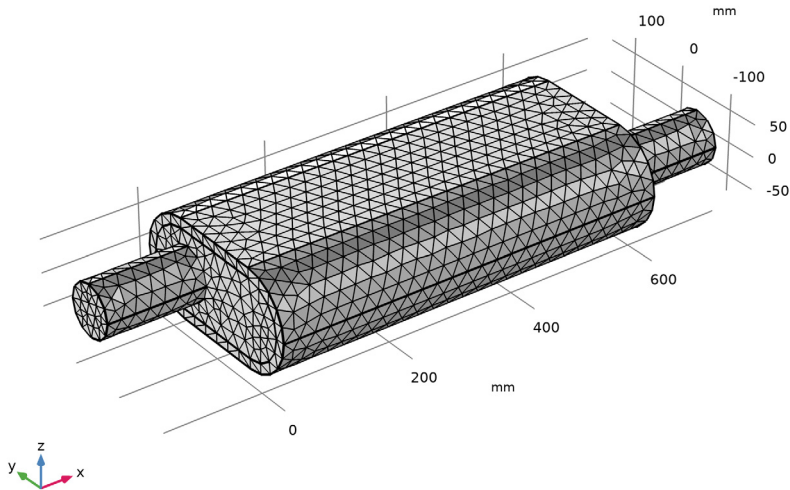

- 1 In the **Model Builder** window, under **Component 1 (comp1)>Mesh 1** click **Size**.
- 2 In the **Settings** window for **Size**, locate the **Element Size** section.
- 3 Click the **Custom** button.
- 4 Locate the **Element Size Parameters** section. In the **Maximum element size** text field, type $343[\text{m/s}]/2800[\text{Hz}]/5$.
- 5 In the **Minimum element size** text field, type $343[\text{m/s}]/2800[\text{Hz}]/6$.
The global maximum element size is set equal to the minimal wavelength divided by 5, that is, $\lambda_{\min}/5 = c/f_{\max}/5$, where c is the speed of sound.
- 6 Click  **Build All**.



STUDY 1 - NO LINER

- 1 In the **Model Builder** window, click **Study 1**.
- 2 In the **Settings** window for **Study**, type Study 1 - No Liner in the **Label** text field.

Step 1: Frequency Domain

- 1 In the **Model Builder** window, under **Study 1 - No Liner** click **Step 1: Frequency Domain**.
- 2 In the **Settings** window for **Frequency Domain**, locate the **Study Settings** section.
- 3 In the **Frequencies** text field, type range (50, 25, 2800).
- 4 Locate the **Physics and Variables Selection** section. Select the **Modify model configuration for study step** check box.
- 5 In the **Physics and variables selection tree**, select **Component 1 (comp1)> Pressure Acoustics, Frequency Domain (acpr)>Poroacoustics 1**.
- 6 Click  **Disable**.
- 7 In the **Home** toolbar, click  **Compute**.

RESULTS

Acoustic Pressure (*acpr*)

The first one of the default plots shows the pressure distribution on the walls of the muffler at the highest frequency, 2800 Hz.

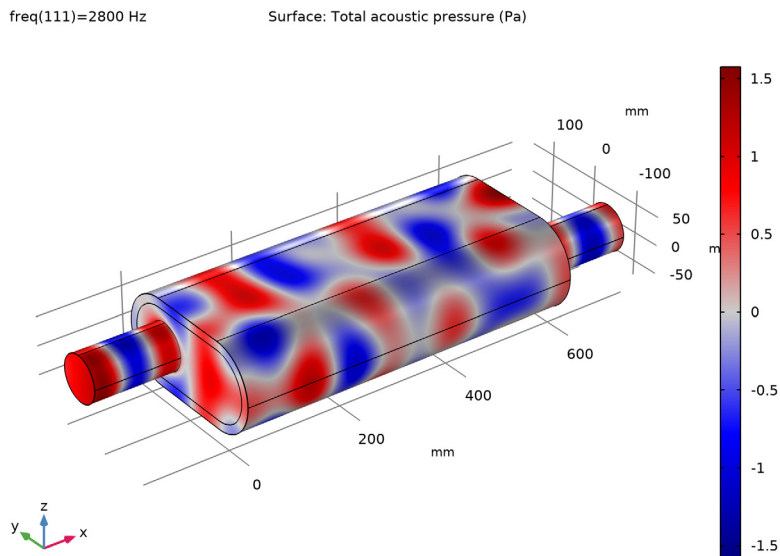

The two other default plot groups show the sound pressure level on the wall surface and the pressure inside the muffler as isosurfaces.

Acoustic Pressure, Isosurfaces (acpr)

freq(111)=2800 Hz

Isosurface: Total acoustic pressure (Pa)

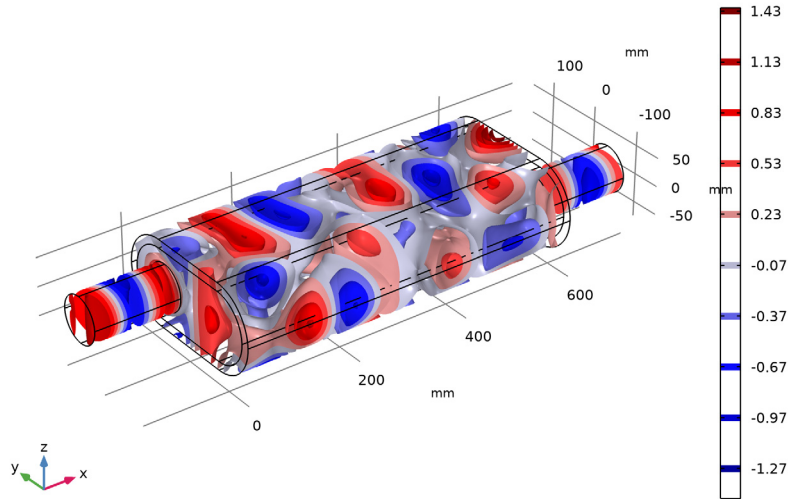

Proceed to plot the transmission loss of the muffler system. Use the Octave Band plot, which makes it possible to plot any transfer function both as band plots and as continuous curves (sweeps).

Transmission Loss, Continuous

- 1 In the **Home** toolbar, click  **Add Plot Group** and choose **ID Plot Group**.
- 2 In the **Settings** window for **ID Plot Group**, type Transmission Loss, Continuous in the **Label** text field.
- 3 Click to expand the **Title** section. From the **Title type** list, choose **Label**.
- 4 Locate the **Plot Settings** section. Select the **y-axis label** check box.
- 5 In the associated text field, type Power, incoming wave (dB, rel. outgoing wave).
- 6 Locate the **Legend** section. From the **Position** list, choose **Upper left**.

Octave Band 1

- 1 In the **Transmission Loss, Continuous** toolbar, click  **More Plots** and choose **Octave Band**.
- 2 In the **Settings** window for **Octave Band**, locate the **Selection** section.

3 From the **Geometric entity level** list, choose **Global**.

Start by locating and inspecting the postprocessing variables available for the port boundary conditions. Add the variable for the power of the incident mode at Port 1. Then modify the expression manually to get the ratio to the power of the outgoing wave at Port 2. This will give the transmission loss.

4 Click **Replace Expression** in the upper-right corner of the **y-Axis Data** section. From the menu, choose **Component 1 (comp1)>Pressure Acoustics, Frequency Domain>Ports>Port 1>acpr.port1.P_in - Power of incident mode - W**.

5 Locate the **y-Axis Data** section. In the **Expression** text field, type $acpr.port1.P_in / (acpr.port4.P_out + acpr.port5.P_out + acpr.port6.P_out)$.

6 From the **Expression type** list, choose **Transfer function**.

7 Locate the **Plot** section. From the **Style** list, choose **Continuous**.

8 Click to expand the **Legends** section. Select the **Show legends** check box.

9 From the **Legends** list, choose **Manual**.

10 In the table, enter the following settings:

Legends
No liner

11 In the **Transmission Loss, Continuous** toolbar, click  **Plot**.

The plot should be a reproduction of the blue curve in [Figure 3](#).

Proceed to solve the model including a layer of absorptive glass wool on the muffler line. Continue working from where you left off with the model developed thus far and add a second study to keep your existing results intact.

ADD STUDY

1 In the **Home** toolbar, click  **Add Study** to open the **Add Study** window.

2 Go to the **Add Study** window.

3 Find the **Studies** subsection. In the **Select Study** tree, select **General Studies>Frequency Domain**.

4 Click **Add Study** in the window toolbar.

5 In the **Home** toolbar, click  **Add Study** to close the **Add Study** window.

STUDY 2 - ABSORPTIVE LINER

1 In the **Model Builder** window, click **Study 2**.

- 2 In the **Settings** window for **Study**, type Study 2 - Absorptive Liner in the **Label** text field.
- 3 Locate the **Study Settings** section. Clear the **Generate default plots** check box.

Step 1: Frequency Domain

- 1 In the **Model Builder** window, under **Study 2 - Absorptive Liner** click **Step 1: Frequency Domain**.
- 2 In the **Settings** window for **Frequency Domain**, locate the **Study Settings** section.
- 3 In the **Frequencies** text field, type range (50,25,2800).
- 4 In the **Home** toolbar, click  **Compute**.

RESULTS

Acoustic Pressure, Isosurfaces (acpr)

You chose not to have new default plots generated. Once the solution process is finished you can use the existing plot groups and just switch the dataset to see how the damping material affects the solution.

- 1 In the **Model Builder** window, under **Results** click **Acoustic Pressure, Isosurfaces (acpr)**.
- 2 In the **Settings** window for **3D Plot Group**, locate the **Data** section.
- 3 From the **Dataset** list, choose **Study 2 - Absorptive Liner/Solution 2 (sol2)**.

4 In the **Acoustic Pressure, Isosurfaces (acpr)** toolbar, click  **Plot**.

freq(111)=2800 Hz

Isosurface: Total acoustic pressure (Pa)

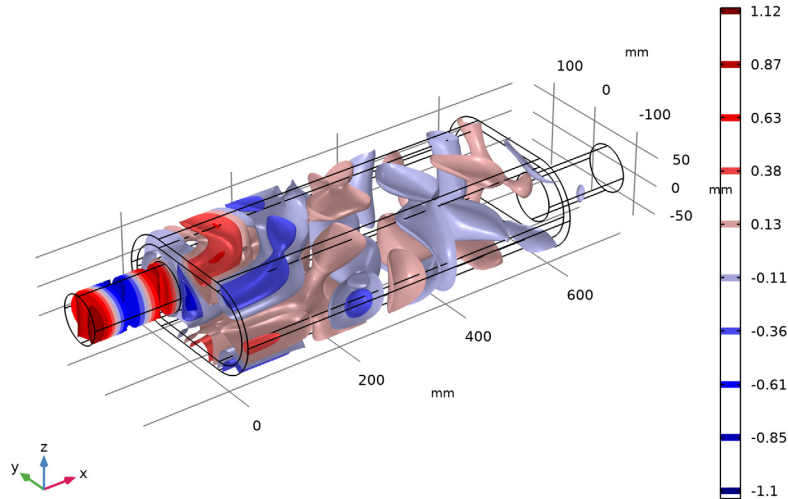

At 1500 Hz, the pressure in the chamber is much lower than before.

Proceed to study how the transmission loss has changed with the addition of the lining. First do a bit of formatting and then duplicate the first plot and select the new dataset.

Octave Band 2

- 1 In the **Model Builder** window, under **Results>Transmission Loss, Continuous** right-click **Octave Band 1** and choose **Duplicate**.
- 2 In the **Settings** window for **Octave Band**, locate the **Data** section.
- 3 From the **Dataset** list, choose **Study 2 - Absorptive Liner/Solution 2 (sol2)**.
- 4 Locate the **Legends** section. In the table, enter the following settings:

Legends

Absorptive liner

- 5 In the **Transmission Loss, Continuous** toolbar, click  **Plot**.

The plot should look like that in [Figure 3](#) top.

Duplicate the Transmission Loss plot and change the format to 1/3 octave bands.

Transmission Loss, 1/3 Octave Bands

- 1 In the **Model Builder** window, right-click **Transmission Loss, Continuous** and choose **Duplicate**.
- 2 In the **Settings** window for **ID Plot Group**, type **Transmission Loss, 1/3 Octave Bands** in the **Label** text field.

Octave Band 1

- 1 In the **Model Builder** window, expand the **Transmission Loss, 1/3 Octave Bands** node, then click **Octave Band 1**.
- 2 In the **Settings** window for **Octave Band**, locate the **Plot** section.
- 3 From the **Style** list, choose **1/3 octave bands**.

Octave Band 2

- 1 In the **Model Builder** window, click **Octave Band 2**.
- 2 In the **Settings** window for **Octave Band**, locate the **Plot** section.
- 3 From the **Style** list, choose **1/3 octave bands**.
- 4 Click to expand the **Coloring and Style** section. From the **Type** list, choose **Outline**.
- 5 In the **Width** text field, type 2.
- 6 In the **Transmission Loss, 1/3 Octave Bands** toolbar, click  **Plot**.
The plot should look like that in [Figure 3](#) bottom.

Now, create a plot that represents the energy flux through the muffler system. Use streamlines that follow the intensity vector. You can change between solutions and frequencies to study and visualize the sound-absorbing properties of the muffler.

Intensity

- 1 In the **Home** toolbar, click  **Add Plot Group** and choose **3D Plot Group**.
- 2 In the **Settings** window for **3D Plot Group**, type **Intensity** in the **Label** text field.

Streamline 1

- 1 Right-click **Intensity** and choose **Streamline**.
- 2 In the **Settings** window for **Streamline**, click **Replace Expression** in the upper-right corner of the **Expression** section. From the menu, choose **Component 1 (comp 1)> Pressure Acoustics, Frequency Domain>Intensity>acpr.lx,acpr.ly,acpr.lz - Intensity**.
- 3 Select **Boundary 1** only.
- 4 Locate the **Coloring and Style** section. Find the **Line style** subsection. From the **Type** list, choose **Tube**.

5 In the **Tube radius expression** text field, type 2.



Color Expression 1

- 1 Right-click **Streamline 1** and choose **Color Expression**.
- 2 In the **Settings** window for **Color Expression**, click **Replace Expression** in the upper-right corner of the **Expression** section. From the menu, choose **Component 1 (comp1)> Pressure Acoustics, Frequency Domain>Intensity>acpr.l_mag - Intensity magnitude - W/m²**.

3 In the **Intensity** toolbar, click  **Plot**.

This should reproduce [Figure 4](#).

Normalized Power Balance

- 1 In the **Home** toolbar, click  **Add Plot Group** and choose **ID Plot Group**.
- 2 In the **Settings** window for **ID Plot Group**, type Normalized Power Balance in the **Label** text field.
- 3 Locate the **Data** section. From the **Dataset** list, choose **Study 2 - Absorptive Liner/ Solution 2 (sol2)**.
- 4 Locate the **Title** section. From the **Title type** list, choose **Label**.
- 5 Locate the **Legend** section. From the **Position** list, choose **Lower left**.
- 6 Click the  **y-Axis Log Scale** button in the **Graphics** toolbar.
- 7 Locate the **Axis** section. Select the **Manual axis limits** check box.
- 8 In the **x minimum** text field, type 10.
- 9 In the **x maximum** text field, type 2850.
- 10 In the **y minimum** text field, type 9e-5.
- 11 In the **y maximum** text field, type 1.1.

Global 1

- 1 Right-click **Normalized Power Balance** and choose **Global**.
- 2 In the **Settings** window for **Global**, locate the **y-Axis Data** section.
- 3 In the table, enter the following settings:

Expression	Unit	Description
acpr.port1.P_out/ acpr.port1.P_in	1	Reflected Power - Plane mode
acpr.port3.P_out/ acpr.port1.P_in	1	Reflected Power - Second azimuthal mode

Expression	Unit	Description
acpr.port4.P_out/ acpr.port1.P_in	1	Transmitted Power - Plane mode
acpr.port6.P_out/ acpr.port1.P_in	1	Transmitted Power - Second azimuthal mode

4 Click to expand the **Legends** section. Find the **Include** subsection. In the **Suffix** text field, type - Absorptive Liner.

5 In the **Normalized Power Balance** toolbar, click  **Plot**.

This should reproduce [Figure 5](#).

Geometry Sequence Instructions

From the **File** menu, choose **New**.

NEW

In the **New** window, click  **Blank Model**.

GLOBAL DEFINITIONS

Parameters 1

1 In the **Model Builder** window, under **Global Definitions** click **Parameters 1**.

2 In the **Settings** window for **Parameters**, locate the **Parameters** section.

3 Click  **Load from File**.

4 Browse to the model's Application Libraries folder and double-click the file absorptive_muffler_geom_sequence_parameters.txt.

ADD COMPONENT

In the **Home** toolbar, click  **Add Component** and choose **3D**.

GEOMETRY 1

1 In the **Settings** window for **Geometry**, locate the **Units** section.

2 From the **Length unit** list, choose **mm**.

Work Plane 1 (wp1)

1 In the **Geometry** toolbar, click  **Work Plane**.

2 In the **Settings** window for **Work Plane**, locate the **Plane Definition** section.



3 From the **Plane** list, choose **yz-plane**.

4 Click  **Show Work Plane**.

Work Plane 1 (wp1)>Rectangle 1 (r1)

- 1 In the **Work Plane** toolbar, click  **Rectangle**.
- 2 In the **Settings** window for **Rectangle**, locate the **Size and Shape** section.
- 3 In the **Width** text field, type W.
- 4 In the **Height** text field, type H.
- 5 Locate the **Position** section. From the **Base** list, choose **Center**.

Work Plane 1 (wp1)>Fillet 1 (fil1)

- 1 In the **Work Plane** toolbar, click  **Fillet**.
- 2 Click the  **Zoom Extents** button in the **Graphics** toolbar.
- 3 On the object **r1**, select Points 1–4 only.

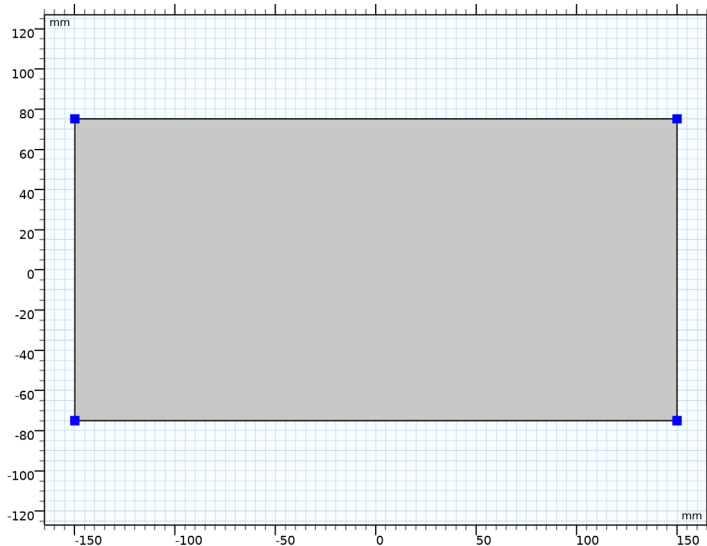

- 4 In the **Settings** window for **Fillet**, locate the **Radius** section.
- 5 In the **Radius** text field, type $H/2$.

Work Plane 1 (wp1)>Rectangle 2 (r2)

- 1 In the **Work Plane** toolbar, click  **Rectangle**.
- 2 In the **Settings** window for **Rectangle**, locate the **Size and Shape** section.
- 3 In the **Width** text field, type $W-2*D$.
- 4 In the **Height** text field, type $H-2*D$.

5 Locate the **Position** section. From the **Base** list, choose **Center**.

Work Plane 1 (wp1)>Fillet 2 (fil2)

1 In the **Work Plane** toolbar, click  **Fillet**.

2 On the object **r2**, select Points 1–4 only.

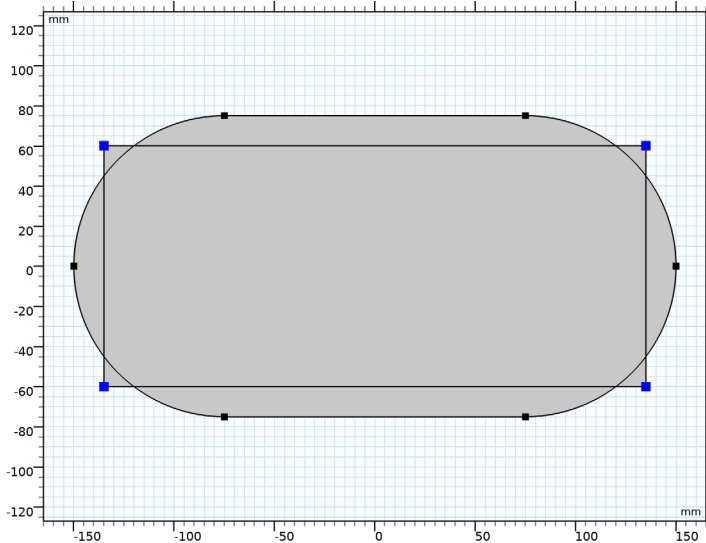

3 In the **Settings** window for **Fillet**, locate the **Radius** section.

4 In the **Radius** text field, type $(H-2*D)/2$.

5 In the **Work Plane** toolbar, click  **Build All**.

Work Plane 1 (wp1)

1 In the **Model Builder** window, click **Work Plane 1 (wp1)**.

2 In the **Work Plane** toolbar, click **Close**.

Extrude 1 (ext1)

1 In the **Geometry** toolbar, click  **Extrude**.

2 In the **Settings** window for **Extrude**, locate the **Distances** section.



3 In the table, enter the following settings:

Distances (mm)
L

Cylinder 1 (cyl1)

- 1 In the **Geometry** toolbar, click  **Cylinder**.
- 2 In the **Settings** window for **Cylinder**, locate the **Size and Shape** section.
- 3 In the **Radius** text field, type R_{io} .
- 4 In the **Height** text field, type L_{io} .
- 5 Locate the **Position** section. In the **x** text field, type $-L_{io}$.
- 6 In the **y** text field, type d_{center} .
- 7 Locate the **Axis** section. From the **Axis type** list, choose **Cartesian**.
- 8 In the **x** text field, type 1.
- 9 In the **z** text field, type 0.

Cylinder 2 (cyl2)

- 1 In the **Geometry** toolbar, click  **Cylinder**.
- 2 In the **Settings** window for **Cylinder**, locate the **Size and Shape** section.
- 3 In the **Radius** text field, type R_{io} .
- 4 In the **Height** text field, type L_{io} .
- 5 Locate the **Position** section. In the **x** text field, type L .
- 6 In the **y** text field, type $-d_{center}$.
- 7 Locate the **Axis** section. From the **Axis type** list, choose **Cartesian**.
- 8 In the **x** text field, type 1.
- 9 In the **z** text field, type 0.
- 10 Click  **Build All Objects**.

II Click the  **Zoom Extents** button in the **Graphics** toolbar.

