

INTRODUCTION TO
LiveLink™ *for* MATLAB®

Introduction to LiveLink™ for MATLAB®

© 2009–2020 COMSOL

Protected by patents listed on www.comsol.com/patents, and U.S. Patents 7,519,518; 7,596,474; 7,623,991; 8,457,932;; 9,098,106; 9,146,652; 9,323,503; 9,372,673; 9,454,625, 10,019,544, 10,650,177; and 10,776,541. Patents pending.

This Documentation and the Programs described herein are furnished under the COMSOL Software License Agreement (www.comsol.com/comsol-license-agreement) and may be used or copied only under the terms of the license agreement.

COMSOL, the COMSOL logo, COMSOL Multiphysics, COMSOL Desktop, COMSOL Compiler, COMSOL Server, and LiveLink are either registered trademarks or trademarks of COMSOL AB. MATLAB and Simulink are registered trademarks of The MathWorks, Inc. All other trademarks are the property of their respective owners, and COMSOL AB and its subsidiaries and products are not affiliated with, endorsed by, sponsored by, or supported by those or the above non-COMSOL trademark owners. For a list of such trademark owners, see www.comsol.com/trademarks.

Version: COMSOL 5.6

Contact Information

Visit the Contact COMSOL page at www.comsol.com/contact to submit general inquiries, contact Technical Support, or search for an address and phone number. You can also visit the Worldwide Sales Offices page at www.comsol.com/contact/offices for address and contact information.

If you need to contact Support, an online request form is located at the COMSOL Access page at www.comsol.com/support/case. Other useful links include:

- Support Center: www.comsol.com/support
- Product Download: www.comsol.com/product-download
- Product Updates: www.comsol.com/support/updates
- COMSOL Blog: www.comsol.com/blogs
- Discussion Forum: www.comsol.com/community
- Events: www.comsol.com/events
- COMSOL Video Gallery: www.comsol.com/video
- Support Knowledge Base: www.comsol.com/support/knowledgebase

Part number: CM020010

Contents

Introduction	5
Starting COMSOL Multiphysics® with MATLAB®	7
A Thorough Example: The Busbar	9
Sharing Applications with the COMSOL Desktop®.....	27
Extracting Results at the MATLAB® Command Line.....	32
Automating with MATLAB® Scripts.....	39
Using External MATLAB® Functions	49

Introduction

LiveLink™ *for* MATLAB® connects COMSOL Multiphysics® to the MATLAB scripting environment. Using this functionality, you can do the following:

- Set up models from a script. LiveLink™ *for* MATLAB® includes the COMSOL® API, which has all the necessary functions and methods to implement models from scratch. For each operation performed in the COMSOL Desktop® there is a corresponding command that is entered at the MATLAB prompt. It is a simplified syntax based on Java® and does not require any Java knowledge.
- Use MATLAB functions in model settings. Use LiveLink™ to set model properties with a MATLAB function. For example, define material properties or boundary conditions as a MATLAB routine that is evaluated while the model is solved.
- Interactive modeling between the COMSOL Desktop and MATLAB sharing the same model. Every modification performed at the MATLAB prompt is simultaneously updated in the COMSOL Desktop.
- Leverage MATLAB functionality for program flow. Use the API syntax together with MATLAB functionality to control the flow of your programs. For example, implement nested loops using `for` or `while` commands, implement conditional model settings with `if` or `switch` statements, or handle exceptions using `try` and `catch`.
- Analyze results in MATLAB. The API wrapper functions included make it easy to extract data at the command line. Functions are available to access results at node points or arbitrary locations. You can also get low-level information about the extended mesh, such as finite element mesh coordinates, and connection information between the elements and nodes. Extracted data are available as MATLAB variables ready to be used with any MATLAB function.
- Create custom interfaces for models. Use the *MATLAB Guide* or the *App Designer* functionality to create a user-defined graphical interface that is combined with a COMSOL model. Make your models available to others by creating graphical user interfaces tailored to expose the settings and parameters of your choice.
- LiveLink™ *for* MATLAB® has the ability to connect to COMSOL Server™ as well as COMSOL Multiphysics Server. This means that MATLAB scripts and GUIs that utilize COMSOL functionality can be distributed to and used by any user that have access to COMSOL Server™.

The examples in this guide take you through the process of setting up a COMSOL model and explain how to use COMSOL Multiphysics within the MATLAB scripting environment.

Starting COMSOL Multiphysics® with MATLAB®

Starting on Windows®

To start COMSOL Multiphysics with MATLAB, double-click the COMSOL with MATLAB icon available on the desktop.

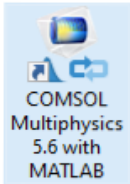

This opens the MATLAB desktop together with the COMSOL Multiphysics Server, which is represented by the command window appearing in the background.

Starting on Mac OS X

Navigate to Applications>COMSOL 5.6>COMSOL 5.6 with MATLAB.

Starting on Linux®

Start a terminal prompt and run the `comsol` command, which is located inside the `bin` folder in the COMSOL installation directory:

```
comsol mphserver matlab
```

The COMSOL Client Server Connection

LiveLink™ *for* MATLAB® provides an interface between COMSOL and MATLAB based on the COMSOL client/server architecture. A COMSOL thin client is running inside MATLAB and has access to the COMSOL API through the MATLAB Java interface. Model information is stored in a *model object* available on the COMSOL Multiphysics Server. The thin client communicates with the

COMSOL Multiphysics Server, enabling you to generate, modify, and solve COMSOL model objects at the MATLAB prompt.

When starting COMSOL with MATLAB, you open both a COMSOL Multiphysics Server and the MATLAB desktop. The first time you start a COMSOL Multiphysics Server you are required to enter a username and password. Once this information is entered, the client/server communication is established. The information is stored in the user preferences, so that subsequent starts do not require you to enter it again.

Both the COMSOL Multiphysics Server and the MATLAB desktop run on the same computer. For computations requiring more memory, you can connect to a remote COMSOL Multiphysics Server, but this configuration requires a floating network license.

Note that the COMSOL Desktop is not necessary when running COMSOL Multiphysics with MATLAB. However, you can connect a COMSOL Desktop to the COMSOL Multiphysics Server and import the model available in the latter. This way the model is updated simultaneously at the MATLAB prompt and in the COMSOL Desktop. See [Sharing Applications with the COMSOL Desktop®](#) for more information.

A Thorough Example: The Busbar

This tutorial familiarizes you with the COMSOL model object and the COMSOL API syntax. In this section, learn how to:

- Create a geometry
- Set up a mesh and apply physics properties
- Solve the problem
- Generate results for analysis
- Exchange the model between the scripting interface of MATLAB and the COMSOL desktop.

The model you are building at the MATLAB command line is the same model described in the *Introduction to COMSOL Multiphysics*. The difference is that, in this guide, you will use a COMSOL model object instead of the COMSOL Desktop.

This multiphysics example describes electrical heating in a busbar. The busbar is used to conduct direct current from a transformer to an electrical device and is made of copper with titanium bolts, as shown in the figure below.

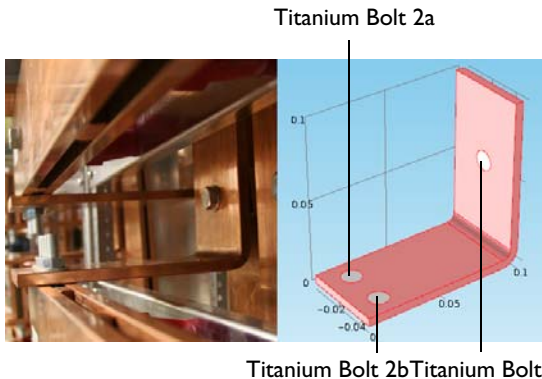

Note: The step-by-step instructions below are designed to be carried out in a sequence. Skipping any of the sections might result in data being unavailable for the following sections. Start with [About The Model Object](#) and work through the sections until reaching the last section, [Saving the Model](#).

About Compact Notation

This example uses *compact notation* to shorten the commands that are entered at the MATLAB command line. The compact notation uses MATLAB variables as links to provide direct access to COMSOL model object features.

For example, to create a block using the compact notation, enter:

```
blk = geom.feature.create('blk1', 'Block');
blk.setIndex('size', '2', 0);
blk.setIndex('size', '3', 1);
```

This creates a block, then changes its width to 2 and its depth to 3.

Compared to above, the commands using a full notation are:

```
geom.feature.create('blk1', 'Block');
geom.feature('blk1').setIndex('size', '2', 0);
geom.feature('blk1').setIndex('size', '3', 1);
```

When a model object is saved in the M-file format, the full notation is always used.

Note: 'blk1' the block geometry tag defined inside the COMSOL model object. The variable `blk`, defined only in MATLAB, is the link to the block feature. By linking MATLAB variables to features, you can directly access and modify features of a COMSOL model object in an efficient manner.

About The Model Object

The model object contains all the information about a model, from the geometry to the results. The model object is defined on the COMSOL Multiphysics Server and can be accessed at the MATLAB command line using a link in MATLAB.

- 1 Start COMSOL with MATLAB, as in the section, [Starting COMSOL Multiphysics® with MATLAB®](#).
- 2 Start modeling by creating a model object on the COMSOL Multiphysics Server. This is done by entering the following command on the MATLAB command line:

```
model = ModelUtil.create('Model');
```

The model object on the COMSOL Multiphysics Server has the tag `Model`, while the variable `model` is its link in MATLAB.

To access and modify the model object, use the COMSOL API syntax. You can get the documentation of a specific API command with the function `mphdoc`.

- 3 To get the documentation of the node `model` from the *COMSOL Programming Reference Manual* enter:

```
mphdoc(model)
```

- 4 To get the documentation of the geometry feature WorkPlane enter:

```
mphdoc(model.geom, 'WorkPlane')
```

Connecting the Model in the COMSOL Desktop®

It is possible to connect the model you are working with from the MATLAB prompt to a COMSOL Desktop. This is a convenient way to follow the modification of the model object while typing at the prompt. See the section, [Sharing Applications with the COMSOL Desktop®](#) for more information.

- 1 At the MATLAB prompt enter:

```
mphlaunch
```

The model is now accessible from both the MATLAB prompt and the COMSOL Desktop. Every command entered at the prompt updates the model on the COMSOL Multiphysics Server and in the COMSOL Desktop.

`mphlaunch` works without arguments if there is only one model loaded on the server. If there is more than one model loaded on the server you need to specify the tag of the model when using `mphlaunch` and the command will write a list of loaded models to choose from. You can use the command `mphtags -show` to get a list of loaded models before using `mphlaunch`.

About Global Parameters

If you plan to solve your model for several different parameter values, it is convenient to define them in the Parameters node and to take advantage of the COMSOL parametric sweep functionality. Global parameters can be used in expressions during all stages of model setup, for example, when creating geometry, applying physics, or defining the mesh.

- 1 Define the parameters for the busbar model:

```
model.param.set('L', '9[cm]', 'Length of the busbar');  
model.param.set('rad_1', '6[mm]', 'Radius of the fillet');  
model.param.set('tbb', '5[mm]', 'Thickness');  
model.param.set('wbb', '5[cm]', 'Width');  
model.param.set('mh', '6[mm]', 'Maximum element size');  
model.param.set('htc', '5[W/m^2/K]', 'Heat transfer coefficient');  
model.param.set('Vtot', '20[mV]', 'Applied electric potential');
```

Geometry

2 You need first to create a component for this model:

```
comp1 = model.component.create('comp1', true);
```

3 In this component, create a 3D geometry node:

```
geom1 = comp1.geom.create('geom1', 3);
```

The create method of the geometry node requires, as input, a tag for the geometry name ('geom1') and the geometry space dimension (3 for 3D).

4 The initial geometry is obtained by extruding a 2D drawing. Create a work plane tagged 'wp1', and set it as the *xz*-plane of the 3D geometry:

```
wp1 = geom1.feature.create('wp1', 'WorkPlane');  
wp1.set('quickplane', 'xz');
```

5 In this work plane, create a rectangle and set the width to $L+2*tbb$ and the height to 0.1:

```
r1 = wp1.geom.feature.create('r1', 'Rectangle');  
r1.set('size', {'L+2*tbb' '0.1'});
```

Note: When the size properties of the rectangle are enclosed within single quotes ' ', it indicates that the variables *L* and *tbb* are defined within the model object. In this case, they are defined in the Parameters node.

6 Create a second rectangle and set the width to $L+tbb$ and the height to $0.1-tbb$. Then change the rectangle position to $(0;tbb)$:

```
r2 = wp1.geom.feature.create('r2', 'Rectangle');  
r2.set('size', {'L+tbb' '0.1-tbb'});  
r2.set('pos', {'0' 'tbb'});
```

7 Subtract rectangle *r2* from rectangle *r1*, by creating a Difference feature with the 'input' property set to *r1* and the 'input2' property set to *r2*:

```
dif = wp1.geom.feature.create('dif', 'Difference');  
dif.selection('input').set({'r1'});  
dif.selection('input2').set({'r2'});
```

To display the current geometry in the COMSOL Desktop, you need to build the geometry node. Enter at the MATLAB prompt:

```
geom1.run;
```

In the COMSOL Desktop, you can visualize the current geometry built at the MATLAB prompt.

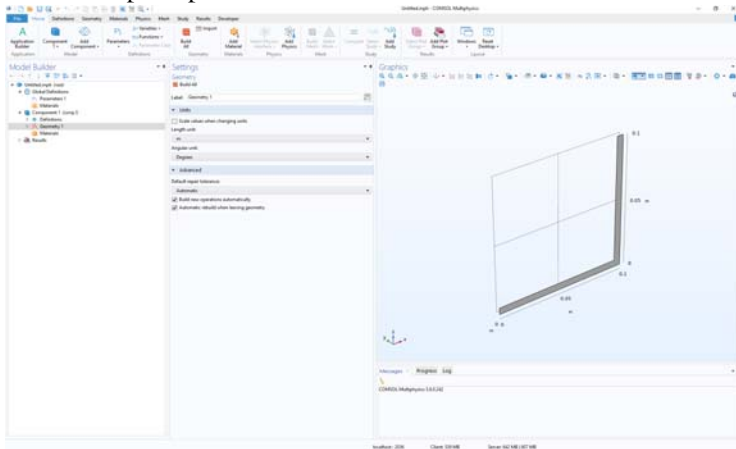

8 Round the inner corner by creating a Fillet feature and set point 3 in the selection property. Then set the radius to tbb :

```
fil1 = wp1.geom.feature.create('fil1', 'Fillet');
fil1.selection('point').set('dif(1)', 3);
fil1.set('radius', 'tbb');
```

9 Round the outer corner by creating a new Fillet feature, then select point 6 and set the radius to $2*tbb$:

```
fil2 = wp1.geom.feature.create('fil2', 'Fillet');
fil2.selection('point').set('fil1(1)', 6);
fil2.set('radius', '2*tbb');
```

For geometry operations, the names of the resulting geometry objects are formed by appending a numeral in parenthesis to the tag of the geometry operation.

Above, 'fil1(1)' is the result of the 'fil1' operation.

10 Extrude the geometry objects in the work plane. Create an Extrude feature, set the work plane $wp1$ as input and the distance to wbb :

```
ext1 = geom1.feature.create('ext1', 'Extrude');
ext1.selection('input').set({'wp1'});
ext1.set('distance', {'wbb'});
```

You can plot the current geometry in a MATLAB figure by entering the following command at the MATLAB prompt:

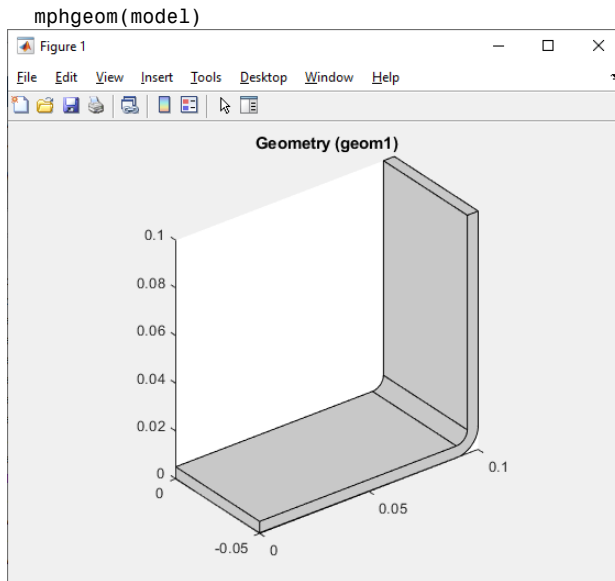

Note that mphgeom automatically builds the geometry node and also updates the COMSOL Desktop.

The busbar shape is now generated. Next, create the cylinders that represent the bolts connecting the busbar to the external frame (not represented in the model).

11 Create a new work plane and set the `planetype` property to `faceparallel`.

Then set the `selection` to boundary 8:

```
wp2 = geom1.feature.create('wp2', 'WorkPlane');
wp2.set('planetype', 'faceparallel');
wp2.selection('face').set('ext1(1)', 8);
```

12 Create a circle and set the radius to `rad_1`:

```
c1 = wp2.geom.feature.create('c1', 'Circle');
c1.set('r', 'rad_1');
```

13 Create an Extrude node, select the second work plane `wp2` as input, and then set the extrusion distance to `-2*tbb`:

```
ext2 = geom1.feature.create('ext2', 'Extrude');
ext2.selection('input').set({'wp2'});
ext2.set('distance', {'-2*tbb'});
```

14 Create a new workplane, set `planetype` to `faceparallel`, then set the `selection` to boundary 4:

```
wp3 = geom1.feature.create('wp3', 'WorkPlane');
wp3.set('planetype', 'faceparallel');
wp3.selection('face').set('ext1(1)', 4);
```

- 15 Create a circle, then set the radius to `rad_1` and set the position of the center to `(-L/2+1.5e-2; -wbb/4)`:

```
c2 = wp3.geom.feature.create('c2', 'Circle');
c2.set('r', 'rad_1');
c2.set('pos', {'-L/2+1.5e-2' '-wbb/4'});
```

- 16 Create a second circle in the work plane by copying the previous circle and displacing it a distance `wbb/2` in the *y* direction:

```
copy = wp3.geom.feature.create('copy', 'Copy');
copy.selection('input').set({'c2'});
copy.set('disply', 'wbb/2');
```

- 17 Extrude the circles `c2` and `copy1` from the work plane `wp3` a distance `-2*tbb`:

```
ext3 = geom1.feature.create('ext3', 'Extrude');
ext3.selection('input').set({'wp3.c2' 'wp3.copy'});
ext3.set('distance', {'-2*tbb'});
```

- 18 Build the entire geometry sequence, including the finalize node using the `run` method:

```
geom1.run;
```

Note: The `run` method only builds features which need rebuilding or have not yet been built, including the finalize node.

This ends the geometry building. In the COMSOL Desktop, you can now see the final model geometry.

Selections

You can create selections of geometric entities such as domains, boundaries, edges, or points. These selections can be accessed during the modeling process with the advantage of not having to select the same entities several times.

- 1 To create a domain selection corresponding to the titanium bolts, named `Ti bolts` enter:

```
sel1 = comp1.selection.create('sel1');
sel1.set([2 3 4 5 6 7]);
sel1.label('Ti bolts');
```

- 2 To visualize the selection in a MATLAB figure enter:

```
mphviewselection(model, 'sel1');
```

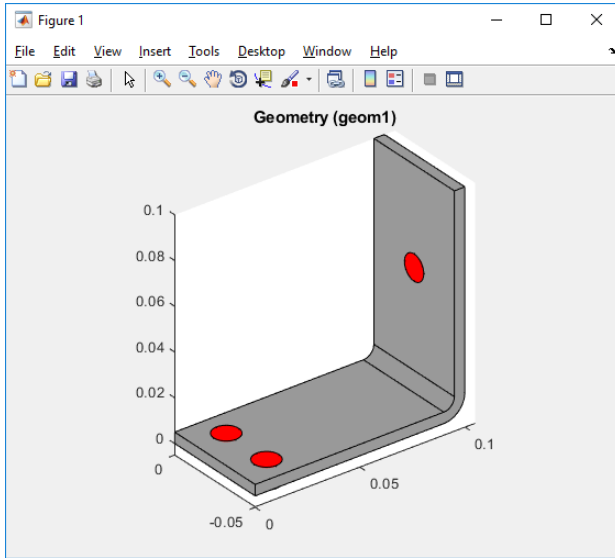

Material Properties

The Material node of the model object stores the material properties. In this example, the Joule Heating interface is used to include both an electric current and a heat balance. Thus, the electrical conductivity, heat capacity, relative permittivity, density, and thermal conductivity of the materials all need to be defined.

The busbar is made of copper and the bolts are made of titanium. The properties you need for these two materials are listed in the table below:

PROPERTY	COPPER	TITANIUM
Electrical conductivity	5.998e7 [S/m]	7.407e5 [S/m]
Heat capacity	385 [J / (kg*K)]	710 [J / (kg*K)]
Relative permittivity	1	1
Density	8700 [kg/m ³]	4940 [kg/m ³]
Thermal conductivity	400 [W / (m*K)]	7.5 [W / (m*K)]

To define material properties using the COMSOL API, you can either create the material from scratch or import the material data from another model MPH-file. In this example you will first create the Copper material node from scratch and then import the Titanium material data from an existing model from the Application library.

- 1 Create the first material, copper:

```
mat1 = comp1.material.create('mat1');
```

- 2 Set the properties for the 'electricconductivity', 'heatcapacity', 'relpermittivity', 'density' and 'thermalconductivity' according to the table above:

```
mat1.materialModel('def').set('electricconductivity', {'5.998e7[S/m]'});  
mat1.materialModel('def').set('heatcapacity', '385[J/(kg*K)]');  
mat1.materialModel('def').set('relpermittivity', {'1'});  
mat1.materialModel('def').set('density', '8700[kg/m^3]');  
mat1.materialModel('def').set('thermalconductivity', {'400[W/(m*K)]'});
```

- 3 Set the name of the material to 'Copper'. By default the first material is assigned to all domains:

```
mat1.label('Copper');
```

Now you will import Titanium material data from the busbar model MPH-file that is available in the COMSOL Multiphysics Application Library.

- 4 Get the list of the material nodes defined in the model busbar.mph:

```
modelRef =  
'<COMSOL_path>\applications\COMSOL_Multiphysics\Multiphysics\busbar.mph'  
';  
ModelUtil.scanModel(modelRef, 'Material', 'op')
```

where *<COMSOL_path>* is the path of your COMSOL installation root directory. From the output, one can see that the material node contains two materials. The second material mat2 is the one defining Titanium beta-21S data and that's the one you will import in the model in the steps below.

- 5 Import material mat2 from the model busbar.mph to the material node of the current model:

```
comp1.material.insert(modelRef, 'mat2', '');
```

- 6 Assign the newly created material to selection 'sel1' (corresponding to the bolt domains) created previously:

```
comp1.material('mat2').selection.named('sel1');
```

Only one material per domain can be assigned. This means that the last operation automatically removes the bolts from the selection of the copper material.

Physics Interface

The Physics node contains the settings of the physics interfaces, including the domain and the boundary settings. Settings are grouped together according to the physics interface they belong to. To model the electrothermal interaction of this example, add the `ConductiveMedia` and `HeatTransfer` interfaces to the model. Apply a fixed electric potential to the upper bolt and ground the two lower bolts. In addition, assume that the device is cooled by convection, approximated by a heat flux with a defined heat transfer coefficient on all outer faces, except where the bolts are connected.

- 1 Create the `Heat Transfer` interface on the `geom1` geometry:

```
ht = comp1.physics.create('ht', 'HeatTransfer', 'geom1');
```

- 2 Add to the physics interface a heat flux boundary condition and set the type to `InwardHeatFlux`:

```
hf1 = ht.feature.create('hf1', 'HeatFluxBoundary', 2);
```

Note: The third argument of the `create` method, the space dimension `sdim`, indicates at which geometry level (domain, boundary, edge, or point) the feature should be applied to. In the above commands, the `'HeatFluxBoundary'` feature applies to boundaries, which have the space dimension 2.

- 3 Now apply cooling to all exterior boundaries 1 to 43 except the bolt connection boundaries 8, 15, and 43. An `InwardHeatFlux` boundary condition requires a heat transfer coefficient. Set its value to the previously defined parameter `htc`:

```
hf1.set('HeatFluxType', 'InwardHeatFlux');  
hf1.selection.set([1:7 9:14 16:42]);  
hf1.set('h', 'htc');
```

- 4 As you may have noticed, defining selections requires you to know the entity indices. To view the boundary indices, display the geometry with the face labels:

```
mphgeom(model, 'geom1', 'facemode', 'off', 'faceLabels', 'on')
```

You can use the controls in the window to zoom and pan to read off the indices.

Note: Alternative methods for obtaining entity indices are described in the *LiveLink™ for MATLAB® User's Guide*. These include the use of point coordinates, selection boxes, or adjacency information.

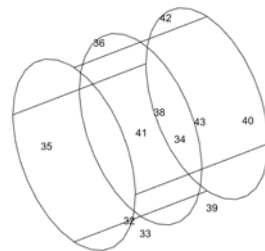

- 5 Create the `Conductive Media` interface on the `geom1` geometry:

```
ec = comp1.physics.create('ec', 'ConductiveMedia', 'geom1');
```

- 6 Now create an electric potential boundary condition and set the selection to boundary 43; then set the electric potential to V_{tot} :

```
pot1 = ec.feature.create('pot1', 'ElectricPotential', 2);  
pot1.selection.set(43);  
pot1.set('V0', 'Vtot');
```

- 7 Apply a ground boundary condition to boundaries 8 and 15:

```
gnd1 = ec.feature.create('gnd1', 'Ground', 2);  
gnd1.selection.set([8 15]);
```

The model object includes default properties so you do not need to set properties for all boundaries. For example, the **Conductive Media** interface uses a current insulation as a default boundary condition for the current balance.

Multiphysics Interface

The Multiphysics Couplings node contains the possible couplings between the physics interfaces used in the model. To model the electrothermal interaction in this example, add the **Electromagnetic Heating** coupling to the model. This node is included by default when modeling Electromagnetic heating in the COMSOL Desktop.

- 1 Create the **ElectromagneticHeating** coupling on the **comp1** component and set the selection to all domains:

```
comp1.multiphysics.create('emh', 'ElectromagneticHeating');
```

The **Heat Transfer** and the **Conductive Media** interfaces are automatically included in the coupling.

Mesh

The mesh sequence is stored in the Mesh node. Several mesh sequences, also called mesh cases, can be created in the same model object.

- 1 Create a new mesh case for **comp1**:

```
mesh = comp1.mesh.create('mesh');
```

- 2 By default, the mesh sequence contains at least a **size** feature, which applies to all the subsequent meshing operations. First create a link to the existing **size** feature. Then set the maximum element size **hmax** to **mh** and the minimum element size **hmin** to **mh-mh/3**. Set the curvature factor **hcurve** to **0.2**:

```
size = mesh.feature('size');  
size.set('hmax', 'mh');
```

```
size.set('hmin', 'mh-mh/3');  
size.set('hcurve', '0.2');
```

3 Create a free tetrahedron mesh:

```
mesh.feature.create('ftet', 'FreeTet');
```

4 Build the mesh:

```
mesh.run;
```

Now look in the COMSOL Desktop to see the resulting mesh in the graphics window.

5 To visualize the mesh in a MATLAB figure, use the command `mphmesh`:

```
mphmesh(model)
```

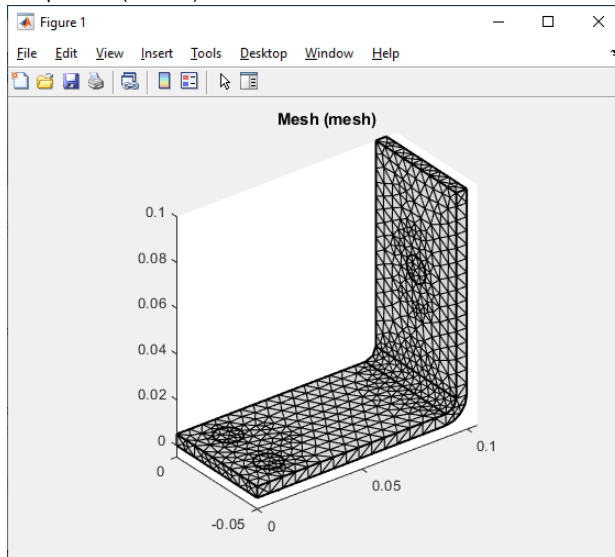

Study

In order to solve the model, you need to create a Study node where the analysis type is set for the solver.

1 Create a study node and add a stationary study step:

```
std = model.study.create('std');  
stat = std.feature.create('stat', 'Stationary');
```

2 By default, the progress bar for the solve and mesh operations is not displayed. To activate the progress bar enter:

```
ModelUtil.showProgress(true);
```

Once activated, the progress bar is displayed in a separate window during mesh or solver operations. The Progress window also contains log information.

Note: The progress bar is not available on Mac OS X.

3 Solve the model with the command:

```
std.run;
```

During the computation, a window opens to display the progress information and solver log.

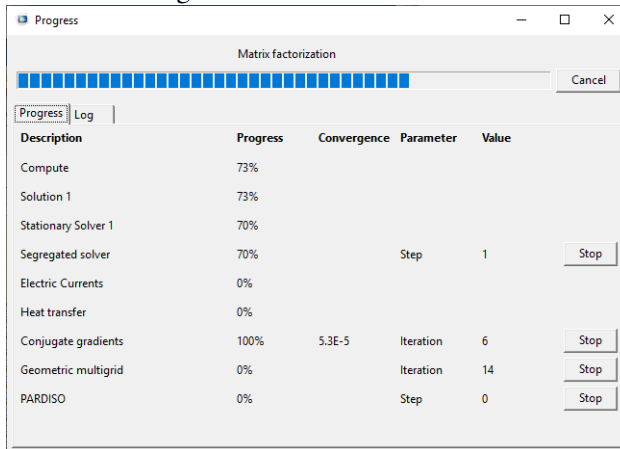

Note: In this example, no solver related settings were necessary since the study node automatically built the solver sequence based on the study type, physics interface, and the space dimension of the model.

Plotting The Results

Analyze the results by defining plot groups in the results node. To display the generated plots in a MATLAB figure, use the `mphp1ot` command.

1 Create a 3D plot group:

```
pg = model.result.create('pg', 'PlotGroup3D');
```

2 In the plot group, create a surface plot to display the busbar temperature:

```
surf = pg.feature.create('surf', 'Surface');  
surf.set('expr', 'T');
```

You can switch to the COMSOL Desktop. In the Model Builder, select the 3D Plot Group 1 node to visualize the results.

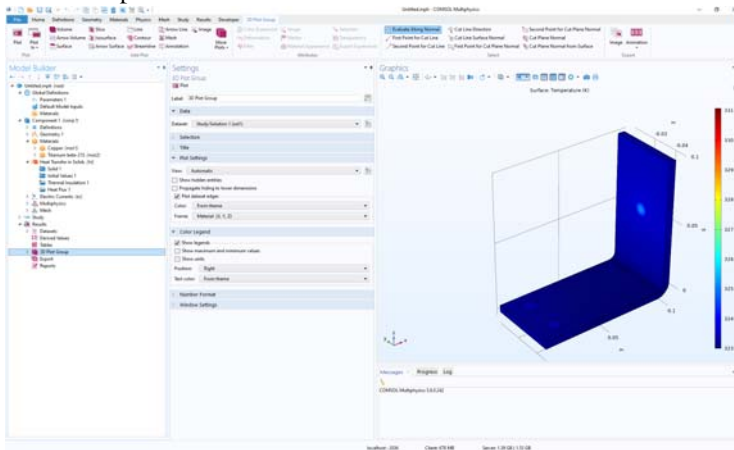

You may notice that the maximum temperature region is located in the bolt. To get a better rendering of the temperature distribution within the busbar, you need to change the color range.

3 Activate a manual color range; set the minimum color value to **322.9** and set the maximum color value to **323.5**:

```
surf.set('rangecoloractive', 'on');  
surf.set('rangecolormin', '322.9');  
surf.set('rangecolormax', '323.5');
```

4 To display the plot group, including a color bar, in a MATLAB figure:

```
mphplot(model, 'pg', 'rangenum', 1)
```

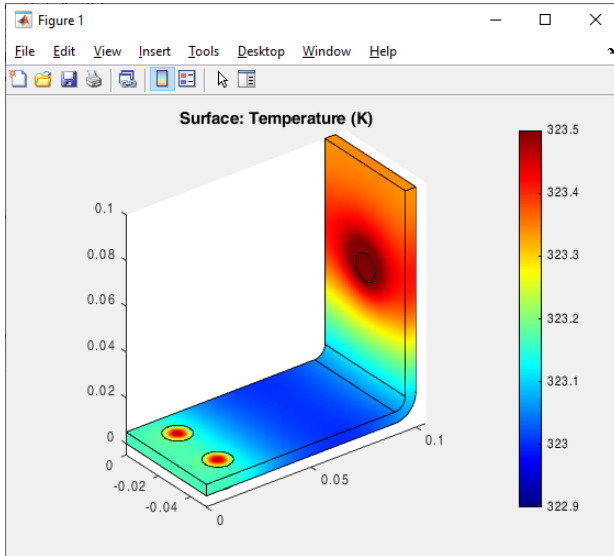

Note: If several plot types are available in the same plot group, you can define which color bar to display. The value of the rangenum property corresponds to the plot type number in the plot group sequence.

Exporting Results

Using LiveLink for MATLAB, you can export the data either to a text file using the Export feature available in the model, or you can export data directly to the MATLAB workspace using the COMSOL function suite available in MATLAB. See the section [Extracting Results at the MATLAB® Command Line](#) for more information on exporting data in MATLAB.

Using the Export node, results can be easily exported to a text file.

- | By entering the commands below, create a data export node to export the temperature variable T. Set the filename to `<filepath>\Temperature.txt` where `<filepath>` is replaced with the path to the directory where the file should be saved.

```
data = model.result.export.create('data', 'Data');
data.setIndex('expr', 'T', 0);
data.set('filename', '<filepath>\Temperature.txt');
```

```
data.run;
```

The above steps extract the temperature at each computational node of the geometry and store the data in a text file in the following format:

```
% Model:                Untitled.mph
% Version:              COMSOL 5.6.0.250
% Date:                 Oct 1 2020, 15:08
% Dimension:           3
% Nodes:                1312
% Expressions:          1
% Description:          Temperature
% Length unit:         m
% X                    Y                    Z                    T (K)
0.09999999             -0.02200000             0.06019615             323.68558476
0.09820196             -0.02200000             0.06019615             323.596789
0.09999999             -0.02297579             0.0644970              323.5223948
0.09999999             -0.01831402             0.06212975             323.51932098
```

Saving the Model

I To save the model using the `save` method enter:

```
mphysave(model, '<path>/busbar');
```

In the above command, replace `<path>` with the directory where you would like to save your model. If a path is not defined, the model is saved in MATLAB's current directory. You can use the command `pwd` to get the current directory in MATLAB.

The default save format is the COMSOL binary format with the `mph` extension. To save the model as an M-file use the command:

```
mphysave(model, '<path>/busbar.m');
```

Code for use with MATLAB®

```
model = ModelUtil.create('Model');
model.param.set('L', '9[cm]', 'Length of the busbar');
model.param.set('rad_1', '6[mm]', 'Radius of the fillet');
model.param.set('tbb', '5[mm]', 'Thickness');
model.param.set('wbb', '5[cm]', 'Width');
model.param.set('mh', '6[mm]', 'Maximum element size');
model.param.set('htc', '5[W/m^2/K]', 'Heat transfer coefficient');
model.param.set('Vtot', '20[mV]', 'Applied electric potential');
comp1 = model.component.create('comp1', true);
geom1 = comp1.geom.create('geom1', 3);
wp1 = geom1.feature.create('wp1', 'WorkPlane');
wp1.set('quickplane', 'xz');
r1 = wp1.geom.feature.create('r1', 'Rectangle');
r1.set('size', {'L+2*tbb' '0.1'});
r2 = wp1.geom.feature.create('r2', 'Rectangle');
```

```

r2.set('size', {'L+tbb' '0.1-tbb'});
r2.set('pos', {'0' 'tbb'});
dif = wp1.geom.feature.create('dif', 'Difference');
dif.selection('input').set({'r1'});
dif.selection('input2').set({'r2'});
geom1.run;
fil1 = wp1.geom.feature.create('fil1', 'Fillet');
fil1.selection('point').set('dif(1)', 3);
fil1.set('radius', 'tbb');
fil2 = wp1.geom.feature.create('fil2', 'Fillet');
fil2.selection('point').set('fil1(1)', 6);
fil2.set('radius', '2*tbb');
ext1 = geom1.feature.create('ext1', 'Extrude');
ext1.selection('input').set({'wp1'});
ext1.set('distance', {'wbb'});
mphgeom(model)
wp2 = geom1.feature.create('wp2', 'WorkPlane');
wp2.set('planetype', 'faceparallel');
wp2.selection('face').set('ext1(1)', 8);
c1 = wp2.geom.feature.create('c1', 'Circle');
c1.set('r', 'rad_1');
ext2 = geom1.feature.create('ext2', 'Extrude');
ext2.selection('input').set({'wp2'});
ext2.set('distance', {'-2*tbb'});
wp3 = geom1.feature.create('wp3', 'WorkPlane');
wp3.set('planetype', 'faceparallel');
wp3.selection('face').set('ext1(1)', 4);
c2 = wp3.geom.feature.create('c2', 'Circle');
c2.set('r', 'rad_1');
c2.set('pos', {'-L/2+1.5e-2' '-wbb/4'});
copy = wp3.geom.feature.create('copy', 'Copy');
copy.selection('input').set({'c2'});
copy.set('disply', 'wbb/2');
ext3 = geom1.feature.create('ext3', 'Extrude');
ext3.selection('input').set({'wp3.c2' 'wp3.copy'});
ext3.set('distance', {'-2*tbb'});
geom1.run;
sel1 = comp1.selection.create('sel1');
sel1.set([2 3 4 5 6 7]);
sel1.label('Ti bolts');
mphviewselection(model, 'sel1');
mat1 = comp1.material.create('mat1');
mat1Def = mat1.materialModel('def');
mat1.materialModel('def').set('electricconductivity', {'5.998e7[S/m]'});
mat1.materialModel('def').set('heatcapacity', '385[J/(kg*K)]');
mat1.materialModel('def').set('relpermittivity', {'1'});
mat1.materialModel('def').set('density', '8700[kg/m^3]');
mat1.materialModel('def').set('thermalconductivity', {'400[W/(m*K)]'});
mat1.label('Copper');
ModelUtil.scanModel('<COMSOL_path>\applications\COMSOL_Multiphysics\Multiphysics\busbar.mph', 'Material', 'op')
comp1.material.insert('<COMSOL_path>\applications\COMSOL_Multiphysics\Multiphysics\busbar.mph', 'mat2', '');

```

```

comp1.material('mat2').selection.named('sel1');
ht = comp1.physics.create('ht', 'HeatTransfer', 'geom1');
hf1 = ht.feature.create('hf1', 'HeatFluxBoundary', 2);
hf1.set('HeatFluxType', 'InwardHeatFlux');
hf1.selection.set([1:7 9:14 16:42]);
hf1.set('h', 'htc');
mphgeom(model, 'geom1', 'facemode', 'off', 'facelabels', 'on')
ec = comp1.physics.create('ec', 'ConductiveMedia', 'geom1');
pot1 = ec.feature.create('pot1', 'ElectricPotential', 2);
pot1.selection.set(43);
pot1.set('V0', 'Vtot');
gnd1 = ec.feature.create('gnd1', 'Ground', 2);
gnd1.selection.set([8 15]);
comp1.multiphysics.create('emh', 'ElectromagneticHeatSource');
mesh = comp1.mesh.create('mesh', 'geom1');
size = mesh.feature('size');
size.set('hmax', 'mh');
size.set('hmin', 'mh-mh/3');
size.set('hcurve', '0.2');
mesh.feature.create('ftet', 'FreeTet');
mesh.run;
mphmesh(model)
std = model.study.create('std');
stat = std.feature.create('stat', 'Stationary');
ModelUtil.showProgress(true);
std.run;
pg = model.result.create('pg', 'PlotGroup3D');
surf = pg.feature.create('surf', 'Surface');
surf.set('expr', 'T');
surf.set('rangecoloractive', 'on');
surf.set('rangecolormin', '322.9');
surf.set('rangecolormax', '323.5');
mphplot(model, 'pg', 'rangenum', 1)
data = model.result.export.create('data', 'Data');
data.setIndex('expr', 'T', 0);
data.set('filename', '<filepath>\Temperature.txt');
data.run;
mphsave(model, '<path>/busbar.m');

```



Sharing Applications with the COMSOL Desktop®

While building the busbar model in MATLAB you have learned how to save a model as an MPH-file, which then can be opened from the COMSOL Desktop. From the COMSOL Desktop you can also directly transfer applications to and from MATLAB, this way you can access it from either the MATLAB prompt or the COMSOL Desktop. For example see the modification of the model in the COMSOL Desktop while you are typing at the MATLAB prompt.

Note: On Linux you need to run COMSOL with MATLAB and the COMSOL desktop from the same terminal. Use the ampersand (&) command, for instance, `comsol &` or `comsol mphserver matlab &`.

Transferring a Model to MATLAB®

As described in [The COMSOL Client Server Connection](#), applications created in MATLAB exist on the COMSOL Multiphysics Server, which can be either on a local or remote machine. To transfer a model to MATLAB, export it from the COMSOL Desktop to the COMSOL Multiphysics Server and then create a link to the model in the MATLAB workspace.

- 1 If it is not already open, start a new COMSOL Desktop. From the Home toolbar, select Application Libraries (). In the Application Libraries window, choose COMSOL Multiphysics>Multiphysics>busbar and click Open.
- 2 Start COMSOL with MATLAB (see [Starting COMSOL Multiphysics® with MATLAB®](#)).
- 3 In COMSOL Desktop, from the File menu (Windows users) or from the Options menu (Mac and Linux users), select Client Server>Connect to Server ().

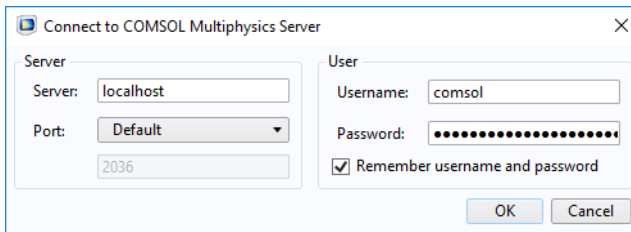

- 4 Confirm that the correct export information is used:
 - In the Server area, define the Server name and the Port number in the fields. The default Server name is localhost, which indicates that the COMSOL

Multiphysics Server is on the same machine. Check the port number by looking at the first line of the text displayed in the COMSOL Multiphysics Server window, the default value is 2036:

COMSOL Multiphysics server 5.6 started listening on port 2036

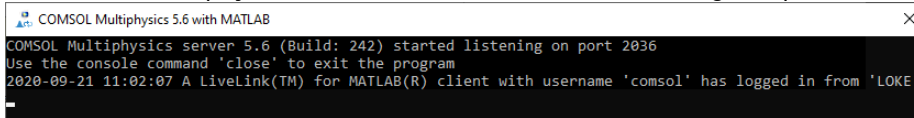

```
COMSOL Multiphysics 5.6 with MATLAB
COMSOL Multiphysics server 5.6 (Build: 242) started listening on port 2036
Use the console command 'close' to exit the program
2020-09-21 11:02:07 A LiveLink(TM) for MATLAB(R) client with username 'comsol' has logged in from 'LOKE'
```

- The User area contains the user login information. The Username and Password fields are set by default based on settings in the user preferences, defined the first time a COMSOL Multiphysics Server is started.

5 Click OK.

Now that the model object is stored in the COMSOL Multiphysics Server, create a link in MATLAB to gain access to it.

6 Once the Export model to server window has closed, you need to create a link in MATLAB to the model exported to the COMSOL Multiphysics Server. At the MATLAB prompt enter:

```
model = mphload('Model1');
```

where 'Model1' is the model object tag in the COMSOL Multiphysics Server. An alternative way to get the list of models available on the COMSOL Multiphysics Server is to enter:

```
mphtags -show
```

7 All features of the model can now be accessed. For example, plot the mesh in a MATLAB figure:

```
mphmesh(model)
```

8 The model can also be modified, for example, by removing the second plot group from the results node:

```
model.result.remove('pg2');
```

You can see in the COMSOL Desktop that the model has been automatically updated while typing at the MATLAB prompt.

Transferring a Model to the COMSOL Desktop®

In addition to transferring your model to MATLAB, a model edited at the MATLAB command line can be accessed from the COMSOL Desktop. It only requires loading the model object from the COMSOL Multiphysics Server to the COMSOL Desktop.

1 Start COMSOL with MATLAB.

2 Create a model object, then create a 3D geometry and draw a block:

```
model = ModelUtil.create('ImportExample');  
model.geom.create('geom1', 3);  
model.geom('geom1').feature.create('blk1', 'Block');  
model.geom('geom1').run;
```

3 To start a COMSOL Desktop, connect it with the COMSOL Multiphysics Server and load the model automatically, enter the command:

```
mphlaunch
```

An alternative to the command `mphlaunch`, you can perform the same operation manually. To connect the COMSOL Desktop, from the File menu (Windows users) or from the Options menu (Mac and Linux users), select COMSOL Multiphysics Server>Connect to Server ().

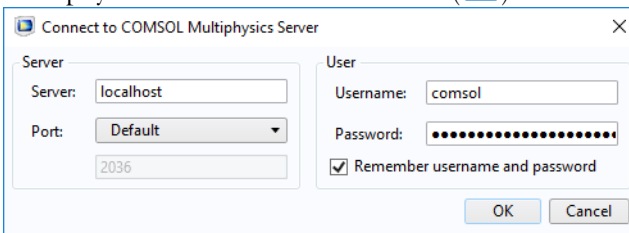

Now that the COMSOL Desktop is connected to the COMSOL Multiphysics Server, you can import the model. From the File menu (Windows users) or from the Options menu (Mac and Linux users), select COMSOL Multiphysics Server>Import Application from Server (). In the Import Application from Server window, select Untitled.mph {ImportExample} which corresponds to the model created previously from the MATLAB prompt.

Saving and Running a Model M-File

The easiest way to learn the commands of the COMSOL API is to save a model from the COMSOL Desktop as an M-file. The M-file contains the sequence of commands that create the model. You can open the M-file in a text editor and make modifications to it, as shown in the following example.

Note: By default, the M-file contains the entire command history of the model following the operation done to the model, this means that the model M-file may include settings that are no longer part of the model. In order to include only settings that are part of the current model, you need to compact the model history before saving the M-file. But if you want to get the command corresponding to the last operation, do not compact the model history

- 1 Start COMSOL with MATLAB and a COMSOL Desktop.
- 2 In the COMSOL Desktop go to the Application Libraries window.
- 3 In the Application Libraries window, expand the COMSOL Multiphysics folder and then the Multiphysics folder. Select the busbar model and click Open.
- 4 A good practice includes compacting the model history in order to get only the command corresponding to the current state of the model. In the COMSOL Desktop, choose File>Compact History ().
- 5 Go to File>Save As. In the Save window, locate Save as type list and select Model file for MATLAB (*.m). Name the file busbar and choose the directory to save it to. Click OK.

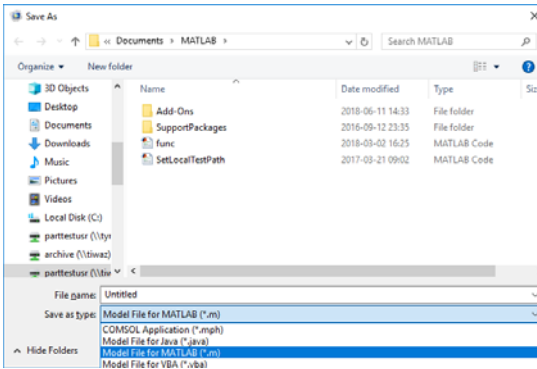

- 6 Open the saved M-file with the MATLAB editor or any text editor and search for the lines below:

```
model.result('pg4').feature('surf1').set('expr', 'ec.normJ');
model.result('pg4').feature('surf1').set('descr', 'Current density norm');
model.result('pg4').feature('surf1').set('rangecolormax', '1e6');
```

The commands above define the plot group **pg4**, it includes a surface plot of the expression for **ec.normJ** and the maximum color range is set to **1e6**.

- 7 Modify the plot group **pg4** so that it displays the total heat **ht.Qtot** and set the maximum color range to **1e4**, append the following to the M-file just before the last command line (output of the function):

```
model.result('pg4').feature('surf1').set('expr', 'ht.Qtot');
model.result('pg4').feature('surf1').set('descr', 'Total heat source');
model.result('pg4').feature('surf1').set('rangecolormax', '1e4');
```

These commands modify plot group **pg4** so that it displays the total heat **ht.Qtot** with a new setting for the maximum value for the color range. You can also directly modify the original lines corresponding to the plot settings to achieve the same thing, but this way you can easily revert to the old version.

- 8 Save the modified M-file.

9 Run the model at the MATLAB prompt with the command:

```
model = busbar;
```

10 Display the plot group pg4:

```
mhplot(model, 'pg4', 'rangenum', 1)
```

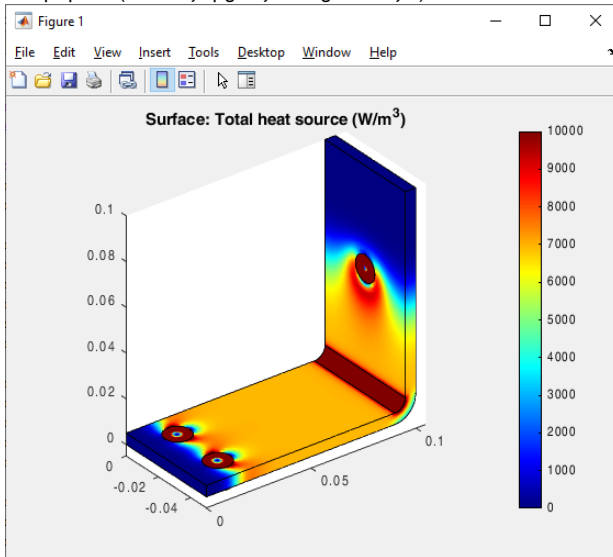

Another way to modify a model object in MATLAB is to load the model in MATLAB, and then enter the commands in step 7 directly at the MATLAB command line. The benefit of this latter approach is that it does not require running the entire model. See [An Example Using Nested Loops](#), where this technique is applied.

Extracting Results at the MATLAB® Command Line

LiveLink™ *for* MATLAB® packages several functions to make it easy to access results directly from the MATLAB command line. The most commonly used functions are:

- `mphinterp`, to evaluate expressions at arbitrary location.
- `mpheval`, to evaluate expressions on all node points of a given domain selection.
- `mphglobal`, to evaluate global expressions.
- `mphint2`, to integrate the value of expressions on selected domains.
- `mphmax`, `mphmin`, and `mphmean`, to evaluate the maximum, minimum and average, respectively, of an expression.
- `mphgetexpressions`, to get the model variables and model parameters expressions.
- `mphevaluate`, to evaluate parameter expressions (constants) in models.

Note: For a complete list of the available functions see the section [Summary of Commands](#) in the *LiveLink for MATLAB User's Guide*.

Load the `busbar` model from the application library directly at the MATLAB command line.

1 Start COMSOL with MATLAB.

2 Load the `busbar` example model from the application library. Enter the command:

```
model = mphopen('busbar');
```

The `mphopen` command automatically searches the MATLAB path as well as the path for the application libraries to find the requested file. You can also specify the path in the filename.

Evaluating Data at Arbitrary Points

If you want to get data at a specific location not necessarily defined by node points, use the command `mphinterp` to interpolate the results. The interpolation method uses the shape function of the elements.

1 To extract the total heat source at `[5e-2; -2e-2; 1e-3]` enter:

```
Qtot = mphinterp(model, 'ht.Qtot', 'coord', [5e-2; -2e-2; 1e-3])
```

This returns:

```
Qtot =  
6.9445e+003
```

- 2 You can specify the unit for evaluation, for instance extract the temperature in Fahrenheit with the command:

```
[Temp, unit]= mphinterp(model,'T','coord',[5e-2;-2e-2;1e-3],'unit','degF')
```

This returns:

```
Temp =  
120.6938
```

```
unit =  
'degF'
```

- 3 A grid of points can also be evaluated. Enter the following lines:

```
x0=0:5e-2/4:5e-2;  
y0=0:-2.5e-2/4:-2.5e-2;  
z0=[0 5e-3];  
[x,y,z]=meshgrid(x0,y0,z0);  
xx=[x(:),y(:),z(:)]';  
Qtot = mphinterp(model,'ht.Qtot','coord',xx);
```

- 4 Reshape the variable `Qtot` for a better visualization:

```
Qtot = reshape(Qtot,length(x0),length(y0),length(z0))
```

This results in:

```
Qtot(:,:,1) =  
1.0e+05 *  
    0.0000    0.0279    0.0738    0.0697    0.0694  
    0.0007    0.3655    0.0735    0.0694    0.0694  
    0.0000    3.2047    0.0672    0.0692    0.0694  
    0.0006    0.2725    0.0734    0.0694    0.0694  
    0.0000    0.0279    0.0738    0.0697    0.0695
```

```
Qtot(:,:,2) =  
1.0e+03 *  
    0.0000    2.8349    7.3450    6.9693    6.9449  
    0.0688    5.3128    6.9927    6.9420    6.9438  
    0.0000    8.8773    5.6019    6.9168    6.9428  
    0.0631    5.2979    7.0218    6.9432    6.9441  
    0.0000    2.8325    7.3530    6.9703    6.9455
```

Evaluating Data at Node Points

Use the `mpheval` function to evaluate the electric potential, which is one of the dependent variables in the busbar model. `mpheval` returns the value of the expression evaluated using the nodes of a simplex mesh. By default, the simplex mesh corresponds to the active mesh in the model object.

1 Enter at the command line:

```
data = mpheval(model, 'V')
```

A MATLAB structure is returned according to:

```
data =  
  expr: {'V'}  
  d1: [1x7373 double]  
  p: [3x7373 double]  
  t: [4x31114 int32]  
  ve: [7373x1 int32]  
  unit: {'V'}
```

`mpheval` returns a MATLAB structure defined with the following fields:

- `expr` contains the list of the evaluated expression,
- `d1` contains the data of the evaluated expression,
- `p` contains the coordinates of the evaluation points,
- `t` contains the indices to columns in the `p` field. Each column in the `t` field corresponds to an element of the mesh used for the evaluation,
- `ve` contains the indices of the mesh elements at each evaluation point,
- `unit` contains the unit of the evaluated expression.

2 Multiple variables can be evaluated at once, for example, both the temperature and the electric potential. Enter:

```
data2 = mpheval(model, {'T' 'V'})
```

This command returns this structure:

```
data2 =  
  expr: {'T' 'V'}  
  d1: [1x7373 double]  
  d2: [1x7373 double]  
  p: [3x7373 double]  
  t: [4x31114 int32]  
  ve: [7373x1 int32]  
  unit: {'K' 'V'}
```

The fields `data2.d1` and `data2.d2` contain the values for the temperature and electric potential, respectively.

3 Now evaluate the temperature `T`, including at the element midpoints as defined by a quadratic shape function. Use the `refine` property and set the property value to 2, which corresponds to the discretization order:

```
data3 = mpheval(model, 'T', 'refine', 2)
```

This command returns this structure:

```
data3 =  
  expr: {'T'}  
  d1: [1x50077 double]
```

```

p: [3x50077 double]
t: [4x248912 int32]
ve: [50077x1 int32]
unit: {'K'}

```

To visualize the evaluation location for both data and data3 together with the mesh, enter the commands:

```

mphmesh(model)
hold on;
plot3(data3.p(1,:),data3.p(2,:),data3.p(3,:),'.');
plot3(data2.p(1,:),data2.p(2,:),data2.p(3,:),'.r');

```

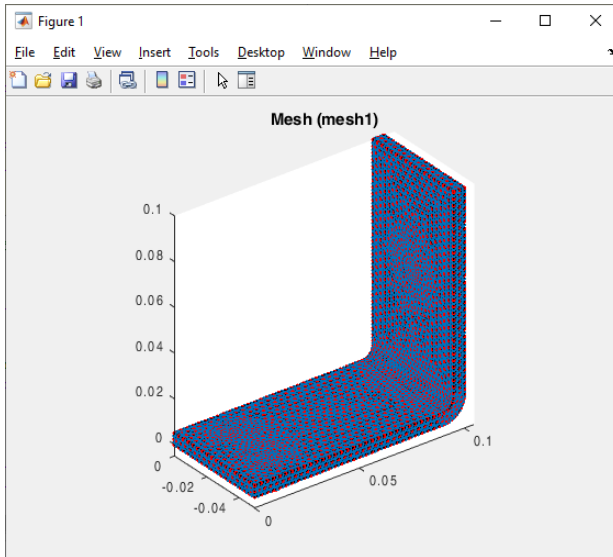

- 4 This step tests how to use the `edim` property in combination with the `selection` property. `edim` allows you to determine the space dimension of the evaluation and `selection` allows you to set the entity number indicating where to evaluate the expression.

Evaluate data on a specific domain, for example, the normal current density at boundary number 43:

```

data4 = mpheval(model,'ec.normJ',...
    'edim','boundary','selection',43)

```

This command returns this structure:

```

data4 =
  expr: {'ec.normJ'}
    d1: [1x65 double]
    p: [3x65 double]
    t: [3x108 int32]
    ve: [65x1 int32]

```

unit: {'A/m^2'}

Global Evaluation and Integration

To get the value of an expression defined with a global scope, use the function `mphglobal`.

- 1 Evaluate the total applied voltage, defined with the parameter `Vtot`:

```
Vtot = mphglobal(model,'Vtot')
```

```
Vtot =  
0.0200
```

- 2 To calculate the total heat produced in the busbar, you can integrate the total heat source using the command `mphint2`. Enter:

```
Q = mphint2(model,'ec.Qh','volume','selection',1)
```

The total heat is:

```
Q =  
0.2420
```

- 3 Evaluate the total current passing through boundary 43 and retrieve the unit of the integral:

```
[I,unit] = mphint2(model,'ec.normJ','surface','selection',43)
```

```
I =  
161.5075
```

```
unit =  
'A'
```

- 4 Evaluate the maximum of the temperature in the busbar:

```
maxT = mphmax(model,'T','volume','selection',1)
```

```
maxT =  
323.0888
```

- 5 Evaluate the maximum of the temperature on boundary 43:

```
maxT = mphmax(model,'T','surface','selection',43)
```

```
maxT =  
330.4131
```

Evaluating Expressions

If you want to evaluate the parameter, or variables, expressions in model use the function `mphgetexpressions`.

- 1 Evaluate the expressions of the parameters defined in the model:

```
expr = mphgetexpressions(model.param)
expr =
    {'L'      } {'9[cm]'      } {'Length'      } {[0.0900]} {'m'}
    {'rad_1'} {'6[mm]'      } {'Bolt radius' } {[0.0060]} {'m'}
    {'tbb'   } {'5[mm]'      } {'Thickness'   } {[0.0050]} {'m'}
    {'wbb'   } {'5[cm]'      } {'Width'       } {[0.0500]} {'m'}
    {'mh'    } {'6[mm]'      } {'Maximum eleme...'} {[0.0060]} {'m'}
    {'htc'   } {'5[W/m^2/K]'} {'Heat transfer...'} {[ 5]} {'W/(m^2*K)'}
    {'Vtot'  } {'20[mV]'     } {'Applied volta...'} {[0.0200]} {'V'}
```

- 2 You can evaluate a specific parameter expression using the function `mpheval`. To evaluate the length of the busbar, L , in inches:

```
L = mpheval(model, 'L', 'in')
L =
    3.5433
```

Note: The evaluation does not require an existing solution dataset in the model.

Code for use with MATLAB®

```
model = mphopen('busbar');

% Evaluating Data at Arbitrary Points
Qtot = mphinterp(model, 'ht.Qtot', 'coord', [5e-2; -2e-2; 1e-3])
[Temp, unit] = mphinterp(model, 'T', 'coord', [5e-2; -2e-2; 1e-3], 'unit', 'degF')
x0=0:5e-2/4:5e-2;
y0=0:-2.5e-2/4:-2.5e-2;
z0=[0 5e-3];
[x,y,z]=meshgrid(x0,y0,z0);
xx=[x(:),y(:),z(:)]';
Qtot = mphinterp(model, 'ht.Qtot', 'coord', xx);
Qtot = reshape(Qtot,length(x0),length(y0),length(z0))

% Evaluating Data at Node Points
data = mpheval(model, 'V')
data2 = mpheval(model, {'T' 'V'})
data3 = mpheval(model, 'T', 'refine', 2)
hold on;
plot3(data3.p(1,:), data3.p(2,:), data3.p(3,:), 'r');
plot3(data2.p(1,:), data2.p(2,:), data2.p(3,:), 'r');
mphmesh(model)

data4 = mpheval(model, {'ec.normJ'}, ...
    'edim', 2, 'selection', 43)

% Global Evaluation and Integration
```

```
Vtot = mphglobal(model,'Vtot')
Q = mphint2(model,'ec.Qh','volume','selection',1)
[I unit] = mphint2(model,'ec.normJ','surface','selection',43)
maxT = mphmax(model,'T','volume','selection',1)
maxT = mphmax(model,'T','surface','selection',43)
```

Automating with MATLAB® Scripts

LiveLink™ *for* MATLAB® enables you to combine the MATLAB programming tools with a COMSOL model object. A benefit of this integration is to access results from the MATLAB workspace. Another benefit is that you can integrate COMSOL modeling commands into MATLAB scripts, taking full advantage of all available tools for controlling the flow of your code. This section explains how to do this efficiently, by introducing MATLAB variables into your COMSOL model and updating only the affected parts of your model object.

Obtaining Model Information

Modifying an existing model object requires you to know how the model is set up. Some functions help you to access this information so that you can add or remove a model feature, or modify the value of an existing property. The function `mphnavigator` helps you to retrieve model object information. Calling `mphnavigator` at the MATLAB prompt displays a summary of the features and their properties for the model object available in the MATLAB workspace.

- 1 Start COMSOL with MATLAB.
- 2 Load the busbar example model:

```
model = mphopen('busbar');
```

or alternative use this simpler form that does the same thing:

```
mphopen busbar
```

- 3 To access the model information, enter the following command at the MATLAB prompt:

```
mphnavigator
```

In the `mphnavigator` graphical user interface, the model features are listed under the Model Tree section. The nodes can be expanded to access the subfeatures. When selecting a feature from the Model Tree, its properties are listed under the Properties section. The Methods section lists the methods available for the selected feature. Just above the Methods section, you can see the COMSOL API syntax that lead to the feature. You can copy the command to the clipboard and easily paste it at the MATLAB prompt — just click the Copy button to copy the syntax.

- 4 In the Model Tree, expand the model feature nodes down to `geom>geom1>wpl>r1` and select the node `r1`.

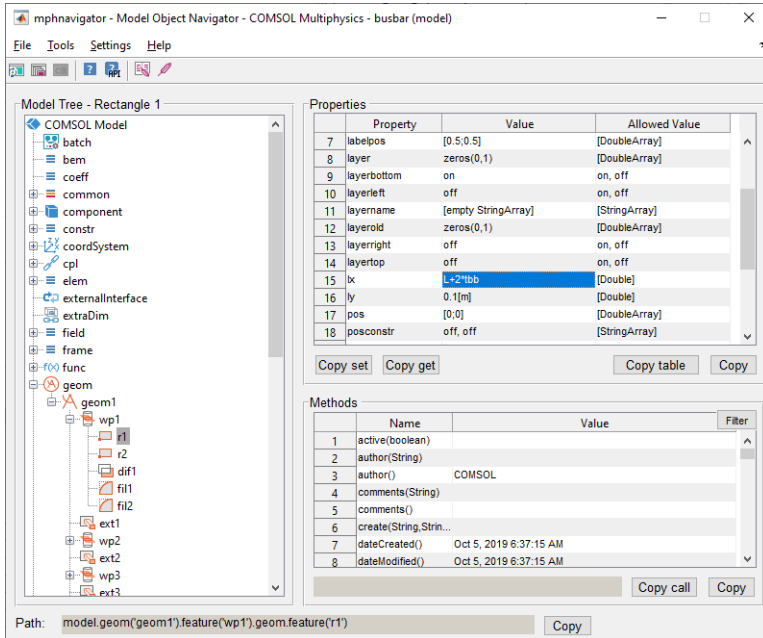

5 In the Properties section, you can see that the lx property of the geometry feature $r1$ is set to $L+2 \cdot t_{bb}$, this represents the length of the rectangle. The width of the rectangle, represented with the property ly is set to 0.1 .

Updating Model Settings

The COMSOL model object allows you to modify parameters, features, or feature properties, using the `set` method. Once a property value is updated, you can run the appropriate sequence, depending on where the changes were introduced into the model — for example, in the geometry or the mesh sequence. Running the solver sequence automatically runs all sequences where modified settings are detected.

Starting with the busbar model described in [A Thorough Example: The Busbar](#), this section modifies a parameter value and resolves the model. For this purpose, the geometry of the model is prepared using parameters such as L for the length of the busbar, and t_{bb} for the thickness of the busbar.

- 1 Start COMSOL with MATLAB (if you have not done so already).
- 2 Load the model from the COMSOL application library:

mphen busbar

3 Plot the current solution with this command:

```
mphplot(model, 'pg4', 'rangenum', 1);
```

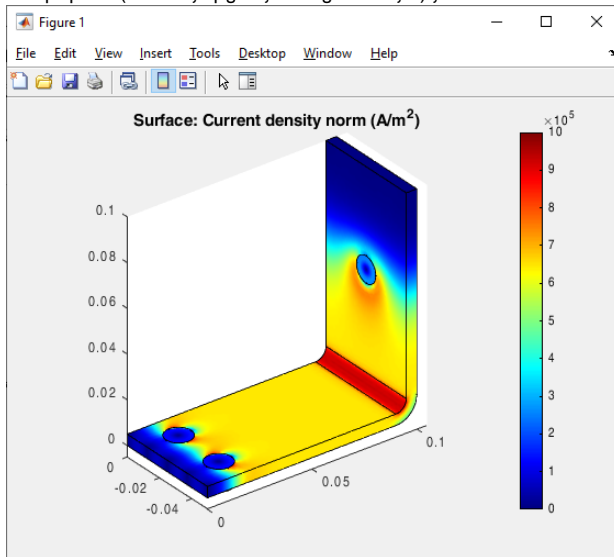

4 The first exercise changes the length parameter L (length of the busbar). Enter:

```
model.param.set('L', '18[cm]');
```

5 To run the solver sequence and compute the solution enter:

```
model.sol('sol1').run;
```

Note: The solver node automatically detects all modifications in the model, and runs the geometry or mesh sequences when needed. Here, the new value for the parameter L induces a change in the geometry, and thus, a new mesh is also needed. Full associativity is also ensured making sure that all physics settings remain applied as in the original model.

6 Plot the updated solution, which results in the geometry change:

```
mphplot(model,'pg4','rangenum',1);
```

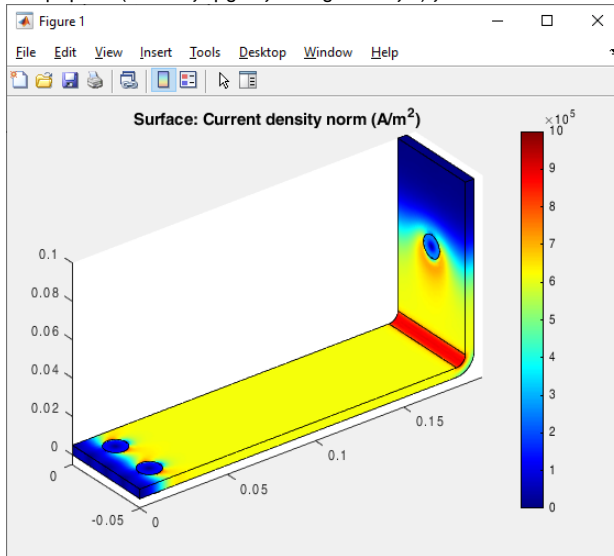

Code for use with MATLAB®

```
model = mphload('busbar');  
mphplot(model,'pg4','rangenum',1);  
model.param.set('L','18[cm]');  
model.sol('sol1').run;  
mphplot(model,'pg4','rangenum',1);
```

Using MATLAB® Variables in the COMSOL Model

Use the `set` method described in the previous section to define the feature properties using MATLAB variables. It is important to make sure that the value of the MATLAB variable is consistent with the units used in the model. Before beginning, make sure that the busbar model used in the previous section is loaded into MATLAB.

First, change the length of the busbar, described by the parameter `L`.

1 Create a MATLAB variable `L0` equal to $9e-2$:

```
L0 = 9e-2;
```

2 Update the value of the parameter `L` with the variable `L0`:

```
model.param.set('L',L0);
```

Note: In contrast to this command, setting a value using an expression from within the model object requires the second argument to be a string expression, as shown in [Updating Model Settings](#).

3 To display the new geometry enter:

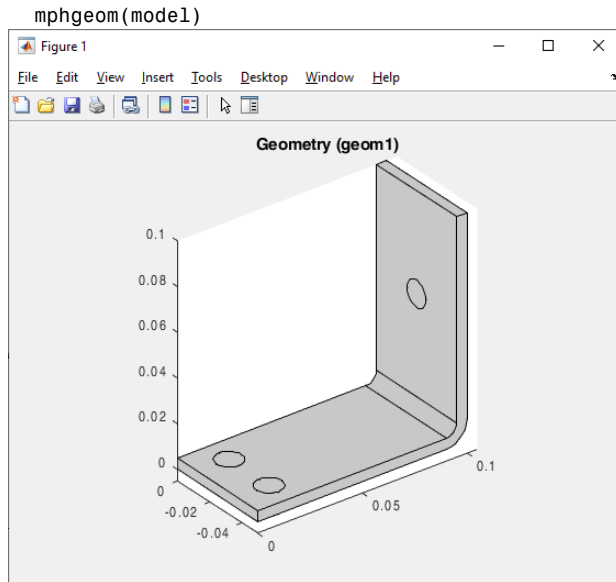

Working with parameters is convenient, since there is only one place where you need to go to view or modify the current configuration of the model. The next step uses a different method, where a feature node is edited to modify its properties. For example, to modify the busbar geometry, the rectangles `r1` and `r2` generated in the work plane `wp1` are edited.

4 Start to create links to the geometry feature `r1` and `r2` by entering the commands:

```
r1 = model.geom('geom1').feature('wp1').geom.feature('r1');  
r2 = model.geom('geom1').feature('wp1').geom.feature('r2');
```

5 Enter the following command to define MATLAB variables:

```
H1 = 0.2;  
H2 = 0.195;
```

6 Set the height of rectangles `r1` and `r2` using the variables `H1` and `H2`, respectively.

```
r1.set('ly', H1);  
r2.set('ly', H2);
```

Note: The function `mphgetproperties` can be used to get a list of properties and values for feature nodes of a model. See [Obtaining Model Information](#) for more details.

7 Enter this command to plot the geometry:

```
mphgeom(model);
```

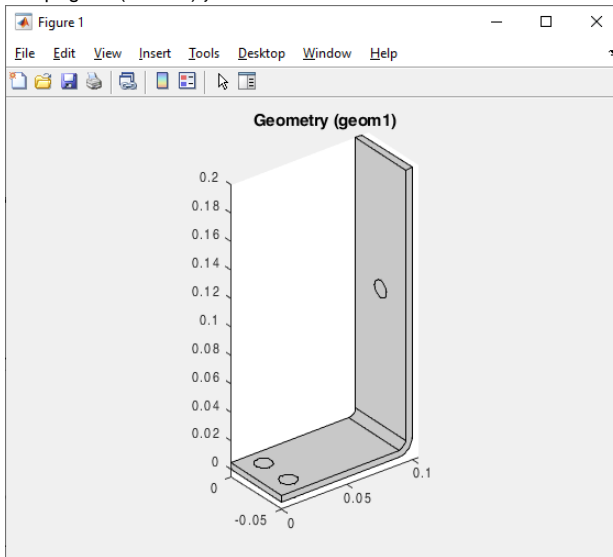

There is a third option when defining property values for features to combine MATLAB variables with parameters or variables defined within the COMSOL model object. To do this, the MATLAB variable needs to be converted to a string. This last exercise demonstrates the method by changing the heights of rectangles `r1` and `r2` to `L0` and `L0 - tbb`, respectively, where `L0` is a MATLAB variable.

8 Define the variable `L0`:

```
L0 = 0.1;
```

9 Modify the `ly` property of rectangles `r1` and `r2`:

```
r1.set('ly',L0);  
r2.set('ly',[num2str(L0) '-tbb']);
```

10 Update and plot the geometry:

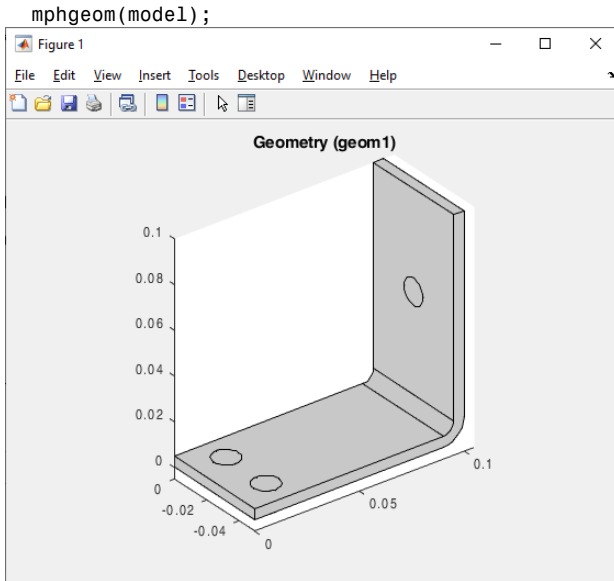

Code for use with MATLAB®

```

model = mphload('busbar');
L0 = 9e-2;
model.param.set('L',L0);
mphgeom(model)

r1 = model.geom('geom1').feature('wp1').geom.feature('r1');
r2 = model.geom('geom1').feature('wp1').geom.feature('r2');
H1 = 0.2;
H2 = 0.195;
r1.set('ly', H1);
r2.set('ly', H2);
mphgeom(model);

L0 = 0.1;
r1.set('ly',L0);
r2.set('ly',[num2str(L0) '-tbb']);
mphgeom(model);

```

An Example Using Nested Loops

In this example, a MATLAB function is created that solves the busbar model for different values of the length and thickness of the busbar in addition to the input electric potential. The function evaluates and returns the maximum temperature in the busbar, the generated heat, and the current through the busbar. For each

variation of the model, the function stores these results in a file and saves the model object in an MPH-file. To make it easy to identify the name of the MPH-file, it contains the values of the different parameters used to set up the model.

The input argument of the M-function is the busbar model object and the path to the directory where the data and models are saved.

1 Open a text editor, for example, the MATLAB text editor.

2 At the first line of a new M-file, enter the following function header:

```
function modelParam(model,filepath)
```

The function first creates a file and then sets the header of the output file format.

3 In the text editor, continue to enter the following lines:

```
filename = fullfile(filepath,'results.txt');  
fid=fopen(filename,'wt');  
fprintf(fid,'*** run parametric study ***\n');  
fprintf(fid,'L[m] | tbb[m] | Vtot[V] | ');  
fprintf(fid,'MaxT[K] | TotQ[W] | Current[A]\n');
```

4 When running a large number of iterations, the model history can be disabled to prevent the memory usage from increasing with each iteration due to the model history stored in the model. Enter the lines:

```
model.hist.disable;
```

5 Now start a for loop to parameterize the parameter L and set the corresponding parameter in the model object. Enter the commands:

```
for L = [9e-2 15e-2]  
model.param.set('L',L);
```

6 Continue by creating a second for loop, this time to parameterize the parameter tbb and to modify its value in the model object:

```
for tbb = [5e-3 10e-3]  
model.param.set('tbb',tbb);
```

7 Define the last for loop to parameterize the applied potential Vtot:

```
for Vtot = [20e-3 40e-3]  
model.param.set('Vtot',Vtot);
```

8 For each version of the model, write the parameter values to the output file:

```
fprintf(fid,[num2str(L), ' | ',num2str(tbb),...  
' | ',num2str(Vtot),' | ']);
```

9 To solve the model, add the line below:

```
model.sol('sol1').run;
```

10 The following lines evaluate the results:

```
MaxT = mphmax(model,'T',3,'selection',1);  
TotQ = mphint2(model,'ht.Qtot',3,'selection',1);
```

```
Current = mphint2(model,'ec.normJ','surface','selection',43);
```

I1 Save the results to the output text file:

```
fprintf(fid,[num2str(MaxT),' | ',num2str(TotQ),...  
' | ',num2str(Current),' \n']);
```

I2 Name and save the model:

```
modelName = fullfile(filepath,['busbar_L=',num2str(L),...  
'_tbb=',num2str(tbb),...  
'_Vtot=',num2str(Vtot),' .mph']);  
mphsave(model,modelName);
```

I3 Terminate the for loops:

```
end  
end  
end
```

I4 Close the output text file:

```
fclose(fid);
```

The script in the text editor should now look like this text:

```
function modelParam(model,filepath)  
filename = fullfile(filepath,'results.txt');  
fid=fopen(filename,'wt');  
fprintf(fid,'*** run parametric study ***\n');  
fprintf(fid,'L[m] | tbb[m] | Vtot[V] | ');  
fprintf(fid,'MaxT[K] | TotQ[W] | Current[A]\n');  
model.hist.disable;  
for L = [9e-2 15e-2]  
    model.param.set('L',L);  
    for tbb = [5e-3 10e-3]  
        model.param.set('tbb',tbb);  
        for Vtot = [20e-3 40e-3]  
            model.param.set('Vtot',Vtot);  
            fprintf(fid,[num2str(L),' | ',...  
                num2str(tbb),' | ',...  
                num2str(Vtot),' | ']);  
            model.sol('sol1').run;  
            MaxT = mphmax(model,'T',3,'selection',1);  
            TotQ = mphint2(model,'ht.Qtot',3,'selection',1);  
            Current = mphint2(model,'ec.normJ','surface',...  
                'selection',43);  
            fprintf(fid,[num2str(MaxT),' | ',...  
                num2str(TotQ),' | ',...  
                num2str(Current),' \n']);  
            modelName = fullfile(filepath,...  
                ['busbar_L=',num2str(L),...  
                '_tbb=',num2str(tbb),...  
                '_Vtot=',num2str(Vtot),' .mph']);  
            mphsave(model,modelName);  
        end  
    end  
end
```

```
fclose(fid);
```

15 Save the M-file as `modelParam.m` in a directory known by MATLAB.

16 If COMSOL with MATLAB is not already running, start it now and load the busbar model from the application library:

```
model = mphload('busbar');
```

17 Run the function and substitute '`filepath`' with the directory of your choice:

```
modelParam(model, 'filepath')
```

18 Open the file `results.txt` in a text editor to look at a summary of the results:

```
*** run parametric study ***  
L[m] | tbb[m] | Vtot[V] | MaxT[K] | TotQ[W] | Current[A]  
0.09 | 0.005 | 0.02 | 323.0949 | 0.24219 | 161.4745  
0.09 | 0.005 | 0.04 | 413.083 | 0.96876 | 322.9491  
0.09 | 0.01 | 0.02 | 308.5286 | 0.04717 | 95.7484  
0.09 | 0.01 | 0.04 | 354.7433 | 0.18867 | 191.4968  
0.15 | 0.005 | 0.02 | 315.7386 | 0.32516 | 156.4376  
0.15 | 0.005 | 0.04 | 383.6202 | 1.3006 | 312.8752  
0.15 | 0.01 | 0.02 | 305.1035 | 0.064331 | 94.8645  
0.15 | 0.01 | 0.04 | 340.964 | 0.25732 | 189.729
```

Although this example duplicates functionality that is readily accessible in the COMSOL Desktop[®], you can use a similar technique to couple a COMSOL model to your customized optimization script.

Using External MATLAB® Functions

Another advantage of using LiveLink™ *for* MATLAB® is the ability to call a MATLAB function directly from within the COMSOL Desktop®. You can use a function to define, within a COMSOL® model object, properties such as material definitions or physics settings. COMSOL automatically detects the external function and starts the MATLAB engine to evaluate it. The function output is then applied to the corresponding property.

To use this functionality, just start the COMSOL Desktop and MATLAB automatically starts in the background when needed.

Note: To run MATLAB function with the model object, you need first to enable external function calls in COMSOL's security settings. To proceed, go to the Preferences > Security and in the list Allow external MATLAB® functions select Yes or Ask.

Note: On Linux operating systems, specify the MATLAB root directory path MLROOT and load the gcc library when starting the COMSOL Desktop: `comsol -mlroot MLROOT -forcegcc`.

The example in this section illustrates how to use external MATLAB functions in a COMSOL model. The model computes the temperature distribution in a material subjected to an external heat flux. Both the thermal conductivity of the material and the applied heat flux are defined by MATLAB functions.

Creating the MATLAB® Functions

Assume that the material in the example is characterized by a random thermal conductivity. To define the thermal conductivity, create a MATLAB function with the x-axis position as an input argument and let the conductivity vary randomly within 200 W/(m·K) around a constant value of 400 W/(m·K).

Define a MATLAB function for the external heat flux to be a function of the following arguments:

- `x` and `y`, the location coordinates.
- `x0` and `y0`, the origin of the heat source.
- `Q0`, the maximum heat source.
- `scale`, a parameter that scales the period of the heat flux.

`x` and `y` are dependent variables of the model. `x0`, `y0`, `Q0`, and `scale` are defined with constant value in this exercise.

The functions must adhere to a certain structure. In order for the calls from COMSOL to MATLAB to be as efficient as possible the arguments are transferred to MATLAB in blocks. This means that for both functions, all the input arguments are vectors, and the functions needs to return vectors with the same length as the input arguments. It is highly recommended to test the functions on the MATLAB command line with some vectors arguments having reasonable values for the arguments in question.

1 Open a text editor, for example the MATLAB text editor.

2 In a new file enter:

```
function out = conductivity(x)
out = 400+5*randn(size(x));
```

3 Save the file as `conductivity.m`.

4 Create a new file and enter:

```
function out = heatflux(x,y,x0,y0,Q0,scale)
radius = sqrt((x-x0).^2+(y-y0).^2);
out = Q0/5+Q0/2.*sin(scale*pi.*radius)./(scale*pi.*radius);
```

5 Save the file in the user Documents folder under MATLAB as `heatflux.m`. Saving the file in this location (`/Documents/MATLAB`) ensures that MATLAB can find the function when COMSOL calls it for evaluation.

Model Wizard

Note: These instructions are for the user interface on Windows, but apply with minor differences also to Linux and Mac.

1 To start the software, double-click the COMSOL Multiphysics icon on the desktop.

2 Select Create a model guided by the Model Wizard .

3 In the space dimension, click 3D .

4 In the Select Physics tree under Heat Transfer , select Heat Transfer in Solids(ht) .



5 Click Add, then click Study .

6 In the Select Study window under General Studies, select Stationary .

7 Click Done .

Defining External MATLAB® Functions in a Model

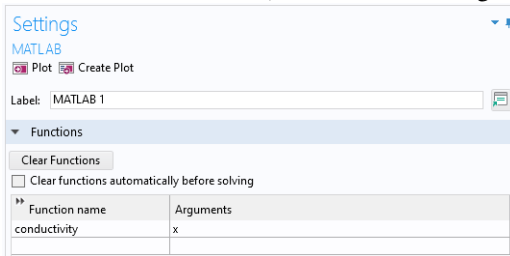

Start by defining a MATLAB function in a model so that COMSOL can recognize it as an external function to be evaluated in the MATLAB engine.

- 1 On the Home toolbar, click Functions . Under the Global section, select MATLAB . On Linux and Mac, the Home toolbar refers to the specific set of controls near the top of the Desktop.
- 2 On the Settings page, under the Functions section in the Function name field enter `conductivity`, and under the Arguments field enter `x`.



By defining the function here, COMSOL knows that `conductivity` is a MATLAB function. COMSOL automatically starts a MATLAB engine to evaluate the function when necessary.

Note: Saving the COMSOL model at the same location as the external MATLAB functions ensures that the function path is known by MATLAB. Other alternatives include setting the function path directly in MATLAB before running the model or setting the environmental variable `COMSOL_MATLAB_PATH` with the directory path of the functions.

- 3 In the COMSOL Desktop, from the File menu (Windows users) or from the Options menu (Mac and Linux users), click Save As . Select Save as MPH-File  and browse to the directory where the files `conductivity.m` and `heatflux.m` are stored.

You can display the value of the defined function by first defining the plot limit for the input arguments.

- 4 Expand the Plot parameters section. In the associated table enter 0 as the Lower limit and 1 as the Upper limit.
- 5 Click the Plot button .

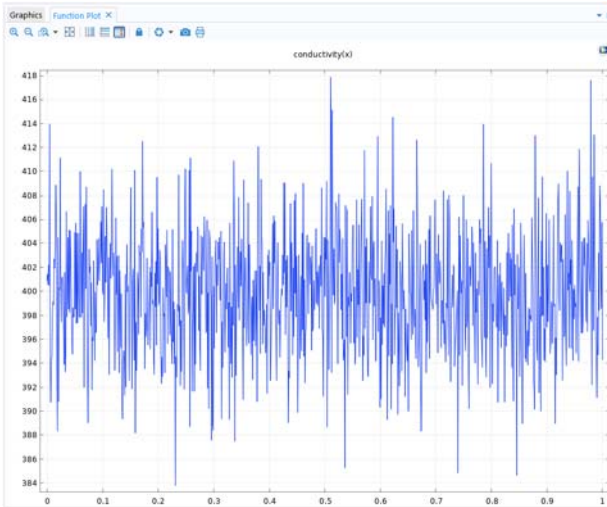

You can now define a second MATLAB function that returns the heat flux condition.

- 6 Repeating the above procedure, enter `heatflux` in the Function name field and set the Arguments field with `x, y, x0, y0, Q0, scale`.

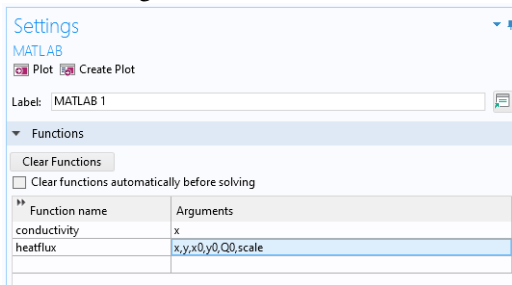

- 7 To display the function, enter the following in the Plot parameters table:

LOWER LIMIT	UPPER LIMIT
0	1
0	1
0	0
0	0
1e4	1e4
5	5

8 Click the Plot button .

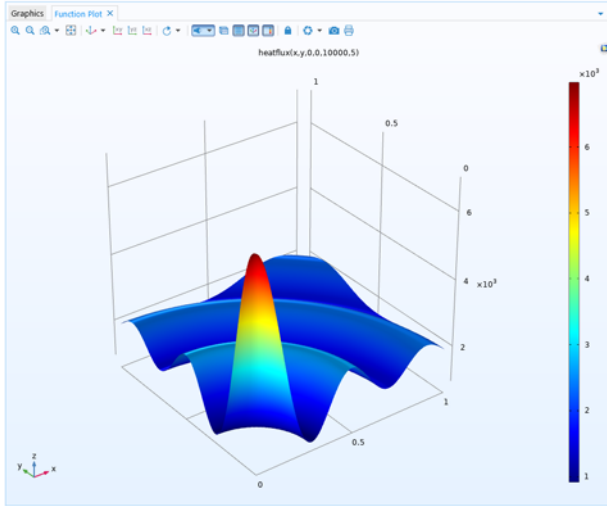



Before you continue with the model settings, you need to manually specify the function derivative with respect to all function arguments otherwise you will get a warning message returned by the solver. For this model, the function arguments are not defined using the temperature (the dependent variable) and the numerical problem can be considered linear. For this reason, you can set the derivative to be 0 for all input arguments.

9 Expand the Derivatives section and complete the table as shown below:

FUNCTION NAME	ARGUMENT	PARTIAL DERIVATIVE
conductivity	x	0
heatflux	x	0
heatflux	y	0
heatflux	x0	0
heatflux	y0	0
heatflux	Q0	0
heatflux	scale	0

Note: For nonlinear problems, it is necessary to specify the partial derivatives. The Partial Derivative column can be set with an expression or another MATLAB function.

Geometry and Material Definition





- 1 On the Geometry toolbar, click Block .
- 2 In the Settings window for Block click Build All Objects .
- 3 On the Material toolbar, click Blank Material .

- 4 In the Settings window for Material under Material Contents, in the Value column, set the expression of the Thermal conductivity to conductivity(x), the expression of Density to 8e3 and the expression of Heat Capacity at Constant Pressure to 2e3.

Material Contents				
Property	Variable	Value	Unit	Property group
<input checked="" type="checkbox"/> Thermal conductivity	k_iso ;...	conduct...	W/(m...	Basic
<input checked="" type="checkbox"/> Density	rho	8e3	kg/m ³	Basic
<input checked="" type="checkbox"/> Heat capacity at constant press...	Cp	2e3	J/(kg·K)	Basic

Note: The expression conductivity(x) displays in orange as the MATLAB function is dimensionless.

Heat Transfer in Solids

- 1 In the Model Builder under Component 1, click Heat Transfer in Solids .
- 2 On the Physics toolbar, click Boundaries  and choose Temperature .
- 3 On the Settings window for Temperature select boundaries 3, 5, and 6 (You can also use the Paste Selection button  to enter directly the selection).

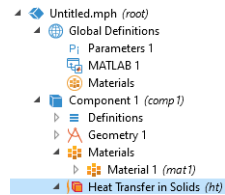

- 4 To add a boundary heat flux, on the Physics toolbar, click Boundaries and select Heat Flux .
- 5 On the Settings window for Heat Flux select boundary 4 and set the General inward heat flux expression to heatflux(x,y,0,0,1e4,5).

Heat Flux

General inward heat flux

q_0 W/m²

Convective heat flux

$q_0 = h \cdot (T_{\text{ext}} - T)$

Heat rate

$q_0 = \frac{P_0}{A}$

Computing and Plotting the Results

Once the model is set up, the solution can be computed. A default mesh is automatically generated.

- 1 On the Study toolbar, click Compute  .
- 2 Click the Temperature (ht) node to display the temperature field at the geometry surface.

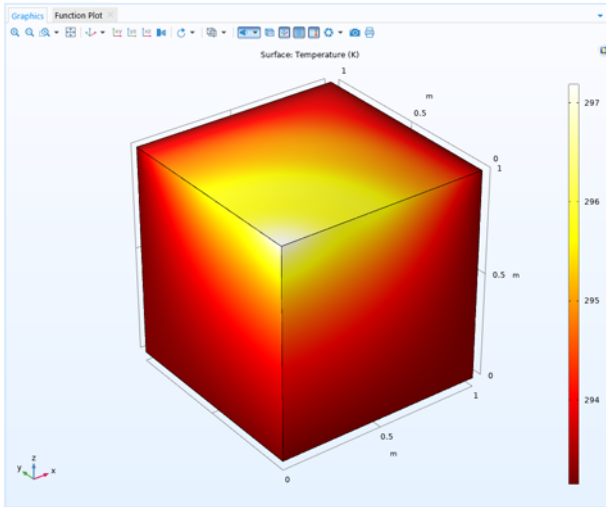

- 1 Visualize the material thermal conductivity on the geometry by adding a new 3D Plot group. In the Results tab, select 3D Plot Group  . An additional toolbar containing Plot Tools for the 3D Plot Group appears when the 3D Plot Group is selected in the Model Builder.

- 2 On the 3D Plot Group 3 toolbar, click Isosurface  .

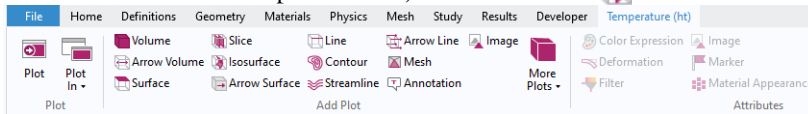

- 3 In the Model Builder under the 3D Plot group 3 node, select the Isosurface 1 node.
- 4 On the associated Settings page, under the Expression section, enter conductivity(x) in the Expression field.
- 5 Under the Levels section, change the Total levels to 15.
- 6 Click the Plot button  .

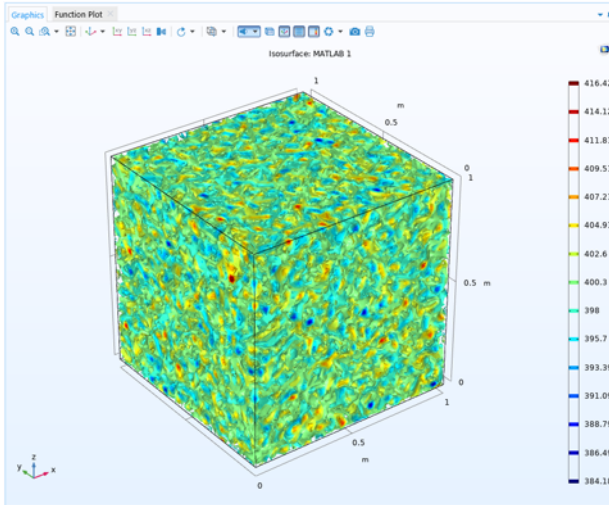

Note: The function conductivity has been evaluated again in MATLAB to generate the above plot. As the function is using a random distribution, the above plot does not exactly represent the distribution of the thermal conductivity when the solution has been computed.