



# Solid Multilayer Shell Comparison

## *Introduction*

---

This example is a benchmark test showing that the **Electric Currents in Layered Shells** physics interface gives results equivalent to those from a model using the **Electric Currents** interface based on a solid 3D representation. [Figure 1](#) shows the solid representation of the model geometry where an aluminum shell and a copper shell are connected through a thin semiconductor layer.

The model solves for the structure both on the true solid representation as shown in [Figure 1](#), and on the approximative shell representation in [Figure 2](#). The shell description is simpler from the geometrical drawing and meshing perspectives, but requires specialized features that offer the option to couple different layer materials properly. A mix of several geometrical junctions and feedings, together with also showing the full 3D equivalent, makes this model suitable as an introduction to the **Electric Currents in Layered Shells** interface.

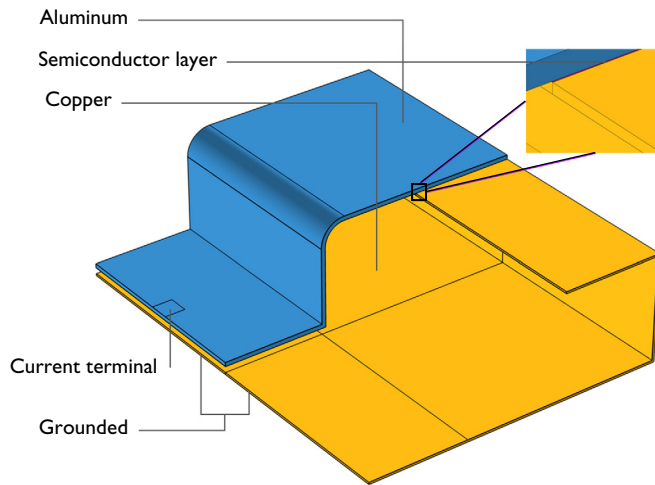

Figure 1: The solid representation of the model.

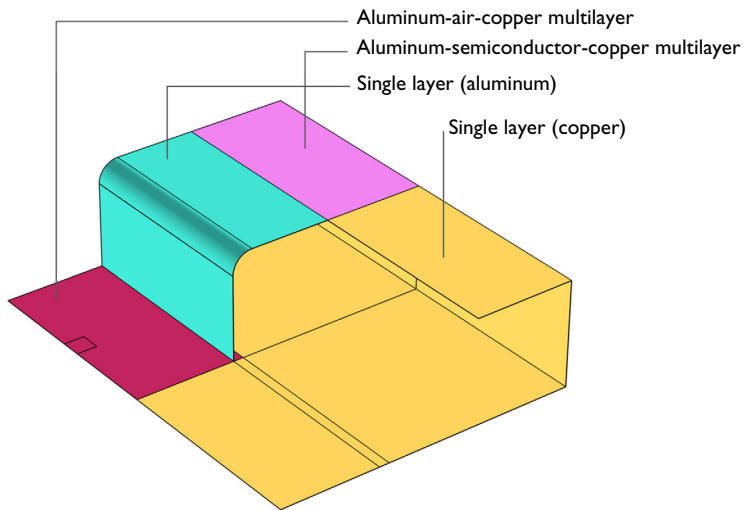

Figure 2: The shell representation of the model.

## Model Definition

The model contains a planar, 0.1 mm thick, semiconductor layer embedded between two thicker complex-shaped metallic profiles. The lower layer is made of copper, while the upper layer is made of aluminum. A current is applied on a square terminal on the upper surface of the aluminum layer, while ground is placed on a lateral surface of the copper. The electrical conductivity of the semiconductor is 1000 S/m, that is considerably lower than that of the connecting metal layers. The aim is to compute and compare the electric potential distribution in the various layers, both for the solid representation and for the layered shell approach.

### MODELING APPROACH

For easy comparison, the model is solved with **Electric Currents** interface and the **Electric Currents in Layered Shells** interface applied on separate objects in the same geometry as shown in figure 3 and 4. In these figures, the solid representation is on the left side, while the shell representation is on the right side.

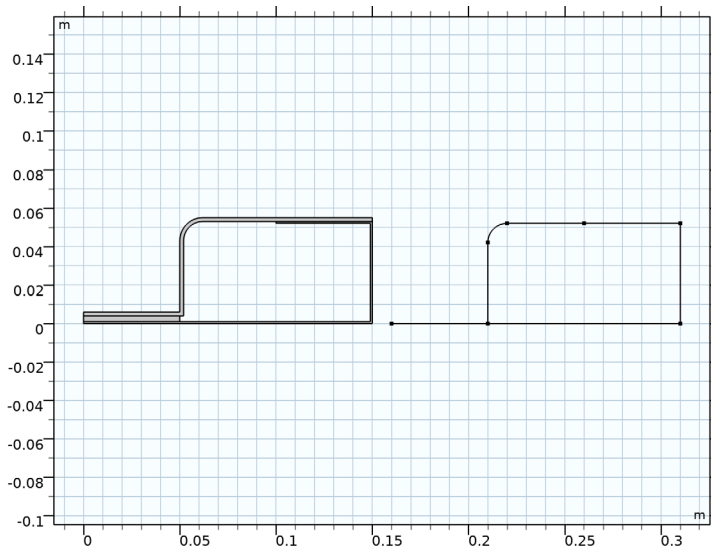
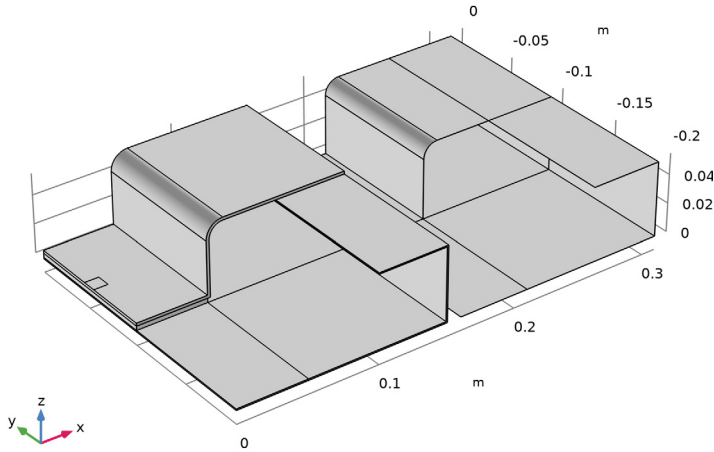

Figure 3: Side view of solid and shell geometric configurations.



*Figure 4: 3D view of solid and shell geometric configurations.*

Solid modeling is, from the physics point of view, the standard choice and usually the most accurate approach. It is featured in many applications including the *Introduction to COMSOL Multiphysics* manual. The only special thing here is that, in the solid representation, the thin semiconductor layer is meshed using a swept mesh. The geometry for the layered shell model does not require any particular attention and a free surface triangular mesh is used.

#### **ON THE ACCURACY OF USING THE ELECTRIC CURRENTS IN LAYERED SHELLS INTERFACE**

The **Electric Currents in Layered Shells** interface represents the shell through boundaries by taking care of the details inside the shell (each Layered Material domain contains an underlying extra dimension where the volumetric 3D physics is represented). By setting the Shell Properties ‘From material’ and checking ‘Use all layers’, the properties of the shell can be automatically detected. Wherever the **Layered Material** is applied (magenta and red regions in [Figure 2](#)) both perpendicular and tangential currents are fully taken into account. Wherever **Single Layer Material** or other material with **Shell** property are applied (yellow and cyan regions in [Figure 2](#)) only tangential currents are accounted for and the electric potential will be constant in the direction normal to the shell. This is physically consistent with the single layer where the current is almost exclusively tangential. The

limitation of the accuracy of the shell model is then essentially within the approximation of the geometrical representation of the shell midplane and the expected discrepancy of solid versus shell models is within the order of the ratio of thickness to length. This means the thinner the shell is, the more accurate the shell model will be, in respect to the exact solution. It is however worth noting that the **Electric Currents in Layered Shells** interface offers features which make it possible to simulate objects which are so thin that a 3D volumetric representation would very cumbersome or expensive due to meshing difficulties.

## Results and Discussion

The model is solved in a stationary study. A solid/volumetric representation of the surface electric potential in the solid and shell objects is plotted in [Figure 5](#). A special dataset enables the user to represent the shell with its appropriate physical thickness and offset.

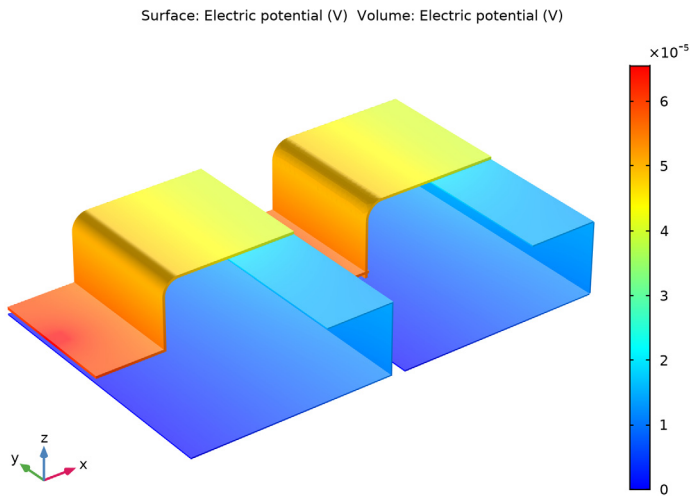

*Figure 5: Electric potential on the solid (left) and on the shell description (right).*

For a more quantitative comparison, in [Figure 6](#), the electric potential is plotted along inner (blue) and outer (red) edge profiles for the solid description (solid line) and for the shell description (symbols). The comparison shows good agreement between the 3D solid model and the layered shell model. Note that the results compare well also in the region where the blue and red lines differ substantially. This region has a significant potential drop in the normal direction that is introduced by the thin semiconductor layer. The agreement

among curves and symbols in the potential drop between red and blue data sets implies that the layered shell model resolves the current perpendicular to the semiconductor layer. The agreement in the potential drop from left to right indicates that the tangential currents are properly solved too. To conclude, this benchmark example showcases the ability of the layered shell interface to describe 3D currents in generic resistive and conductive layered structures.

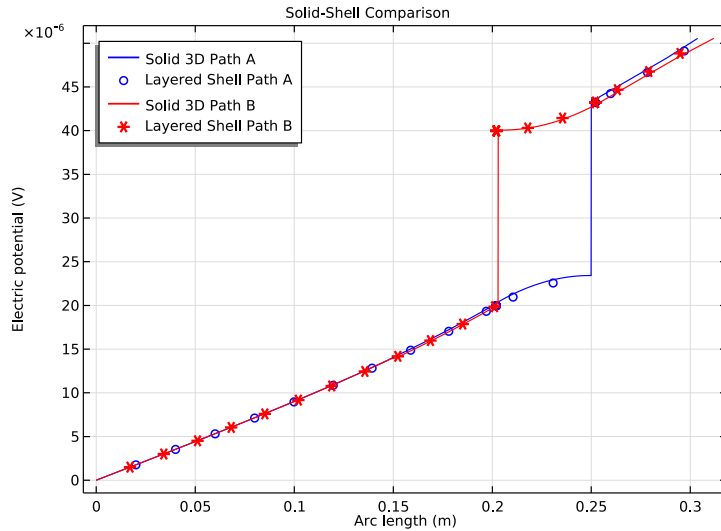

Figure 6: Comparison of the simulated electric potential along Path A and B for the solid and shell description, where the definitions of Path A and B are given in the section Modeling Instructions — Solid-Shell Comparison.

---

**Application Library path:** ACDC\_Module/Layered\_Shell/  
solid\_multilayer\_shell\_comparison

---

### Modeling Instructions

---

From the **File** menu, choose **New**.

#### NEW

In the **New** window, click **Model Wizard**.

## MODEL WIZARD

- 1 In the **Model Wizard** window, click **3D**.
- 2 In the **Select Physics** tree, select **AC/DC>Electric Fields and Currents>Electric Currents (ec)**.
- 3 Click **Add**.
- 4 In the **Select Physics** tree, select **AC/DC>Electric Fields and Currents>Electric Currents in Layered Shells (ecis)**.
- 5 Click **Add**.
- 6 Click **Study**.
- 7 In the **Select Study** tree, select **General Studies>Stationary**.
- 8 Click **Done**.

## GLOBAL DEFINITIONS

### *Parameters I*

- 1 In the **Model Builder** window, under **Global Definitions** click **Parameters I**.
- 2 In the **Settings** window for **Parameters**, locate the **Parameters** section.
- 3 In the table, enter the following settings:

Name	Expression	Value	Description
Cu_thickness	1[mm]	0.001 m	Thickness of copper layer (J shaped lower profile)
Al_thickness	2[mm]	0.002 m	Thickness of aluminum layer (Z shaped upper profile)
Air_thickness	3[mm]	0.003 m	Air gap thickness
Semi_thickness	0.1[mm]	1E-4 m	Thin semiconductor layer thickness

## ADD MATERIAL

- 1 In the **Home** toolbar, click **Add Material** to open the **Add Material** window.
- 2 Go to the **Add Material** window.
- 3 In the tree, select **Built-in>Air**.
- 4 Click **Add to Global Materials**.
- 5 In the tree, select **Built-in>Aluminum**.
- 6 Click **Add to Global Materials**.
- 7 In the tree, select **Built-in>Copper**.



8 Click **Add to Global Materials**.

9 In the **Home** toolbar, click **Add Material** to close the **Add Material** window.

## GLOBAL DEFINITIONS

### *Material 4 (mat4)*

1 In the **Model Builder** window, under **Global Definitions** right-click **Materials** and choose **Blank Material**.

2 In the **Settings** window for **Material**, type Semiconductive Material in the **Label** text field.

3 Click to expand the **Material Properties** section. In the **Material properties** tree, select **Basic Properties>Electrical Conductivity**.

4 Click **Add to Material**.

5 In the **Material properties** tree, select **Basic Properties>Relative Permittivity**.

6 Click **Add to Material**.

7 Locate the **Material Contents** section. In the table, enter the following settings:

Property	Variable	Value	Unit	Property group
Electrical conductivity	sigma_iso ; sigma_ii = sigma_iso, sigma_ij = 0	1000	S/m	Basic
Relative permittivity	epsilon_r_iso ; epsilon_rii = epsilon_r_iso, epsilon_r_ij = 0	1		Basic

### *Layered Material 1 (lmat1)*

1 Right-click **Materials** and choose **Layered Material**.

2 In the **Settings** window for **Layered Material**, type Al-Air-Cu Stack in the **Label** text field.

3 Locate the **Layer Definition** section. Click **Add**.

4 Click **Add**.

5 In the table, enter the following settings:

Layer	Material	Rotation (deg)	Thickness (m)	Mesh elements
Al	Aluminum (mat2)	0.0	Al_thickness	2
Air	Air (mat1)	0.0	Air_thickness	2
Cu	Copper (mat3)	0.0	Cu_thickness	2

*Layered Material 2 (lmat2)*

1 Right-click **Materials** and choose **Layered Material**.

2 In the **Settings** window for **Layered Material**, type Cu-Semi-Al Stack in the **Label** text field.

3 Locate the **Layer Definition** section. Click **Add**.

4 Click **Add**.

5 In the table, enter the following settings:

Layer	Material	Rotation (deg)	Thickness (m)	Mesh elements
Cu	Copper (mat3)	0.0	Cu_thickness	2
Semi	Semiconductive Material (mat4)	0.0	Semi_thickness	2
Al	Aluminum (mat2)	0.0	Al_thickness	2

## GEOMETRY I

*Work Plane 1 (wp1)*

1 In the **Geometry** toolbar, click **Work Plane**.

2 In the **Settings** window for **Work Plane**, locate the **Plane Definition** section.

3 From the **Plane** list, choose **xz-plane**.

4 Click **Show Work Plane**.

*Work Plane 1 (wp1)>Rectangle 1 (r1)*

1 In the **Work Plane** toolbar, click **Rectangle**.

2 In the **Settings** window for **Rectangle**, locate the **Size and Shape** section.

3 In the **Width** text field, type 0.15.

4 In the **Height** text field, type Cu\_thickness.

*Work Plane 1 (wp1)>Rectangle 2 (r2)*

- 1 Right-click **Component 1 (comp1)>Geometry 1>Work Plane 1 (wp1)>Plane Geometry>Rectangle 1 (r1)** and choose **Duplicate**.
- 2 In the **Settings** window for **Rectangle**, locate the **Size and Shape** section.
- 3 In the **Width** text field, type 0.05.
- 4 In the **Height** text field, type `Air_thickness`.
- 5 Locate the **Position** section. In the **yw** text field, type `Cu_thickness`.

*Work Plane 1 (wp1)>Rectangle 3 (r3)*

- 1 Right-click **Component 1 (comp1)>Geometry 1>Work Plane 1 (wp1)>Plane Geometry>Rectangle 2 (r2)** and choose **Duplicate**.
- 2 In the **Settings** window for **Rectangle**, locate the **Size and Shape** section.
- 3 In the **Height** text field, type `Al_thickness`.
- 4 Locate the **Position** section. In the **yw** text field, type `Cu_thickness+Air_thickness`.

*Work Plane 1 (wp1)>Rectangle 4 (r4)*

- 1 Right-click **Component 1 (comp1)>Geometry 1>Work Plane 1 (wp1)>Plane Geometry>Rectangle 3 (r3)** and choose **Duplicate**.
- 2 In the **Settings** window for **Rectangle**, locate the **Size and Shape** section.
- 3 In the **Width** text field, type `Al_thickness`.
- 4 In the **Height** text field, type `0.055-Cu_thickness-Air_thickness`.
- 5 Locate the **Position** section. In the **xw** text field, type 0.05.

*Work Plane 1 (wp1)>Rectangle 5 (r5)*

- 1 Right-click **Component 1 (comp1)>Geometry 1>Work Plane 1 (wp1)>Plane Geometry>Rectangle 4 (r4)** and choose **Duplicate**.
- 2 In the **Settings** window for **Rectangle**, locate the **Size and Shape** section.
- 3 In the **Width** text field, type `Cu_thickness`.
- 4 In the **Height** text field, type `0.055-2*C_u_thickness-Al_thickness`.
- 5 Locate the **Position** section. In the **xw** text field, type `0.15-Cu_thickness`.
- 6 In the **yw** text field, type `Cu_thickness`.

*Work Plane 1 (wp1)>Rectangle 6 (r6)*

- 1 Right-click **Component 1 (comp1)>Geometry 1>Work Plane 1 (wp1)>Plane Geometry>Rectangle 5 (r5)** and choose **Duplicate**.
- 2 In the **Settings** window for **Rectangle**, locate the **Size and Shape** section.

- 3 In the **Width** text field, type 0.1-A1\_thickness.
- 4 In the **Height** text field, type A1\_thickness.
- 5 Locate the **Position** section. In the **xw** text field, type 0.05+A1\_thickness.
- 6 In the **yw** text field, type 0.055-A1\_thickness.

*Work Plane 1 (wp1)>Rectangle 7 (r7)*

- 1 Right-click **Component 1 (comp1)>Geometry 1>Work Plane 1 (wp1)>Plane Geometry>Rectangle 6 (r6)** and choose **Duplicate**.
- 2 In the **Settings** window for **Rectangle**, locate the **Size and Shape** section.
- 3 In the **Width** text field, type 0.05.
- 4 In the **Height** text field, type Cu\_thickness.
- 5 Locate the **Position** section. In the **xw** text field, type 0.1.
- 6 In the **yw** text field, type 0.055-A1\_thickness-Cu\_thickness.

*Work Plane 1 (wp1)>Rectangle 8 (r8)*

- 1 Right-click **Component 1 (comp1)>Geometry 1>Work Plane 1 (wp1)>Plane Geometry>Rectangle 7 (r7)** and choose **Duplicate**.
- 2 In the **Settings** window for **Rectangle**, locate the **Size and Shape** section.
- 3 In the **Height** text field, type Semi\_thickness.
- 4 Locate the **Position** section. In the **yw** text field, type 0.055-A1\_thickness-Semi\_thickness.
- 5 In the **Work Plane** toolbar, click **Build All**.
- 6 Click the **Zoom Extents** button in the **Graphics** toolbar.

*Work Plane 1 (wp1)>Union 1 (uni1)*

- 1 In the **Work Plane** toolbar, click **Booleans and Partitions** and choose **Union**.
- 2 Select the objects **r3**, **r4**, and **r6** only.
- 3 In the **Settings** window for **Union**, locate the **Union** section.
- 4 Clear the **Keep interior boundaries** check box.

*Work Plane 1 (wp1)>Union 2 (uni2)*

- 1 In the **Work Plane** toolbar, click **Booleans and Partitions** and choose **Union**.
- 2 Select the objects **r1**, **r5**, and **r7** only.
- 3 In the **Settings** window for **Union**, locate the **Union** section.
- 4 Clear the **Keep interior boundaries** check box.
- 5 In the **Work Plane** toolbar, click **Build All**.

6 Click the **Zoom Extents** button in the **Graphics** toolbar.

*Work Plane 1 (wp1)>Delete Entities 1 (del1)*

1 In the **Model Builder** window, right-click **Plane Geometry** and choose **Delete Entities**.

2 On the object **unil**, select Boundaries 6 and 9 only.

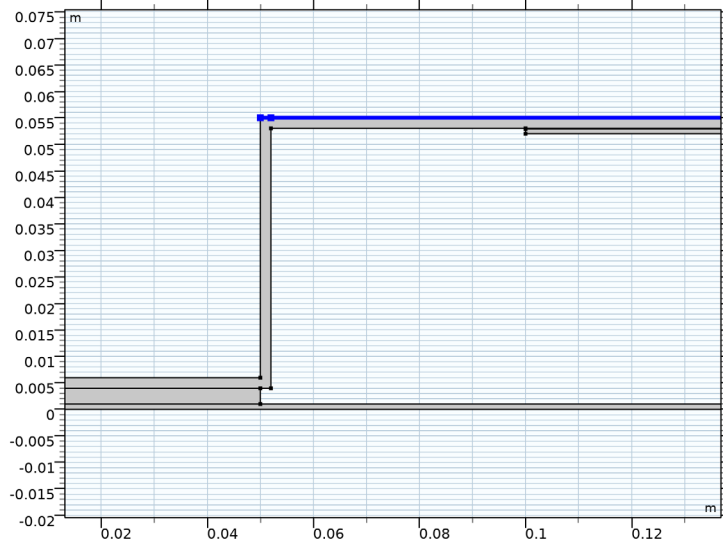

3 In the **Settings** window for **Delete Entities**, click **Build Selected**.

4 Click the **Zoom Extents** button in the **Graphics** toolbar.

*Work Plane 1 (wp1)>Line Segment 1 (ls1)*

1 In the **Work Plane** toolbar, click **More Primitives** and choose **Line Segment**.

2 In the **Settings** window for **Line Segment**, locate the **Starting Point** section.

3 From the **Specify** list, choose **Coordinates**.

4 Locate the **Endpoint** section. From the **Specify** list, choose **Coordinates**.

5 Locate the **Starting Point** section. In the **xw** text field, type 0.05.

6 Locate the **Endpoint** section. In the **xw** text field, type 0.15.

7 Locate the **Starting Point** section. In the **yw** text field, type 0.055.

8 Locate the **Endpoint** section. In the **yw** text field, type 0.055.

*Work Plane 1 (wp1)>Convert to Solid 1 (csol1)*

1 In the **Work Plane** toolbar, click **Conversions** and choose **Convert to Solid**.

2 Select the objects **del1** and **ls1** only.

3 In the **Settings** window for **Convert to Solid**, click **Build Selected**.

*Work Plane 1 (wp1)>Polygon 1 (pol1)*

1 In the **Work Plane** toolbar, click **Polygon**.

2 In the **Settings** window for **Polygon**, locate the **Object Type** section.

3 From the **Type** list, choose **Open curve**.

4 Locate the **Coordinates** section. From the **Data source** list, choose **Vectors**.

5 In the **xw** text field, type 0.16 0.31 0.31 0.31 0.31 0.26 0.26 0.26 0.21 0.21 0.21.

6 In the **yw** text field, type 0 0 0 0.052 0.052 0.052 0.052 0.052 0.052 0 0.

7 In the **Work Plane** toolbar, click **Build All**.

8 Click the **Zoom Extents** button in the **Graphics** toolbar.

*Work Plane 1 (wp1)>Fillet 1 (fil1)*

1 In the **Work Plane** toolbar, click **Fillet**.

2 On the object **csoll**, select Point 7 only.

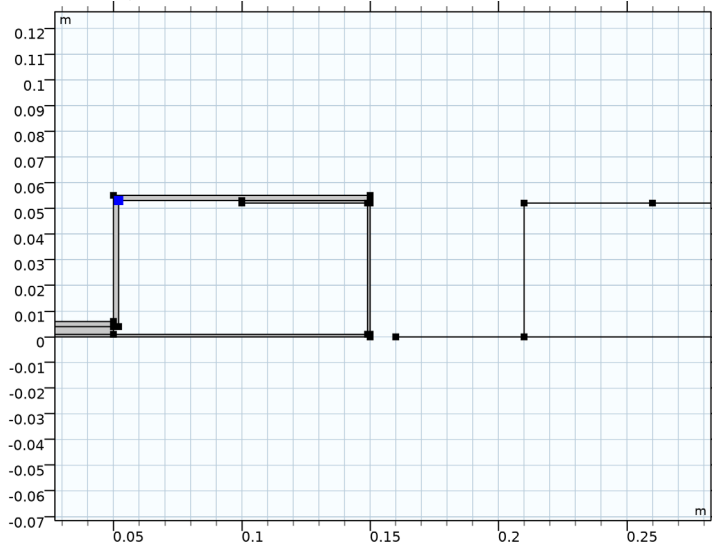

3 In the **Settings** window for **Fillet**, locate the **Radius** section.

4 In the **Radius** text field, type 0.01.

5 Click **Build Selected**.

Work Plane 1 (wp1)>Fillet 2 (fil2)

1 In the **Work Plane** toolbar, click **Fillet**.

2 On the object **fil1**, select Point 5 only.

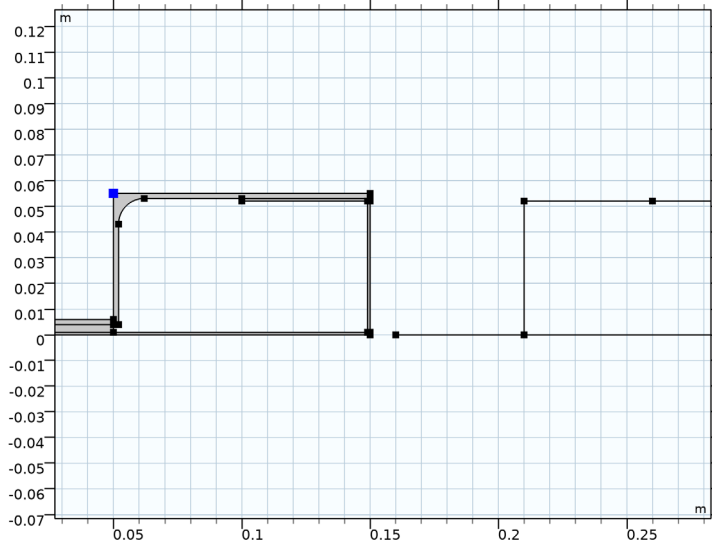

3 In the **Settings** window for **Fillet**, locate the **Radius** section.

4 In the **Radius** text field, type  $0.01+A1\_thickness$ .

5 Click **Build Selected**.

Work Plane 1 (wp1)>Fillet 3 (fil3)

1 In the **Work Plane** toolbar, click **Fillet**.

2 Click the **Zoom Extents** button in the **Graphics** toolbar.

3 On the object **poll**, select Point 3 only.

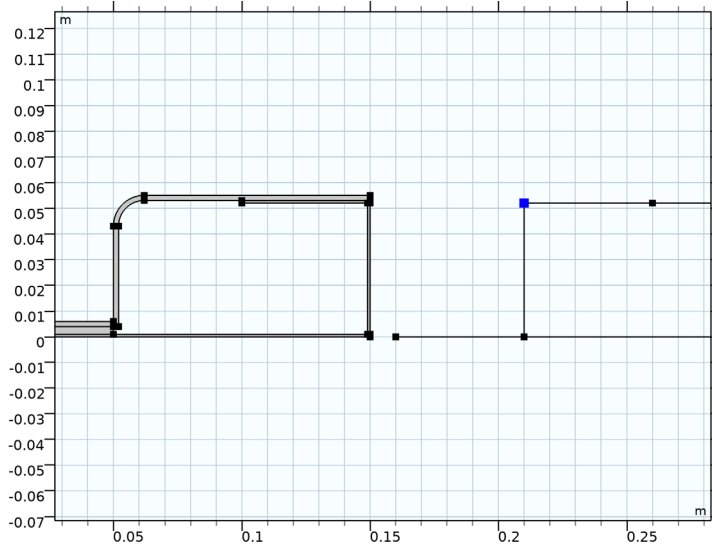

4 In the **Settings** window for **Fillet**, locate the **Radius** section.

5 In the **Radius** text field, type 0.01.

6 Click **Build Selected**.

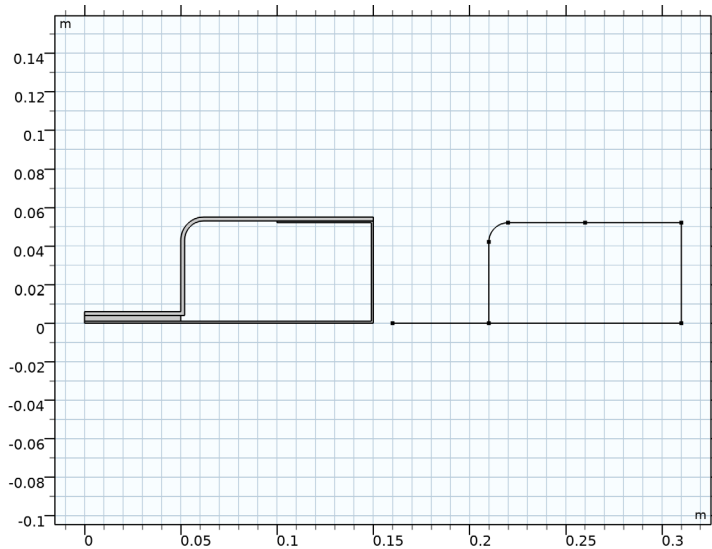

*Work Plane 1 (wp1)*

In the **Model Builder** window, click **Work Plane 1 (wp1)**.



*Extrude 1 (ext1)*

- 1 In the **Geometry** toolbar, click **Extrude**.
- 2 In the **Settings** window for **Extrude**, locate the **Distances** section.
- 3 In the table, enter the following settings:

<b>Distances (m)</b>
0.1
0.2

- 4 Click the **Zoom Extents** button in the **Graphics** toolbar.
- 5 Click **Build Selected**.

*Work Plane 1 (wp1)*

In the **Model Builder** window, collapse the **Component 1 (comp1)>Geometry 1>Work Plane 1 (wp1)** node.

*Delete Entities 1 (del1)*

- 1 In the **Model Builder** window, right-click **Geometry 1** and choose **Delete Entities**.
- 2 In the **Settings** window for **Delete Entities**, locate the **Entities or Objects to Delete** section.
- 3 From the **Geometric entity level** list, choose **Domain**.
- 4 On the object **ext1**, select Domains 2, 3, and 7 only.

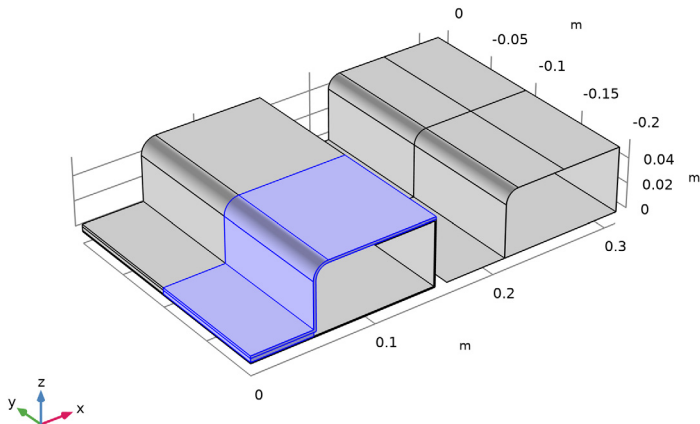

- 5 Click **Build Selected**.

*Delete Entities 2 (del2)*

- 1 Right-click **Geometry I** and choose **Delete Entities**.
- 2 On the object **del1**, select Boundaries 50, 52, and 56 only.

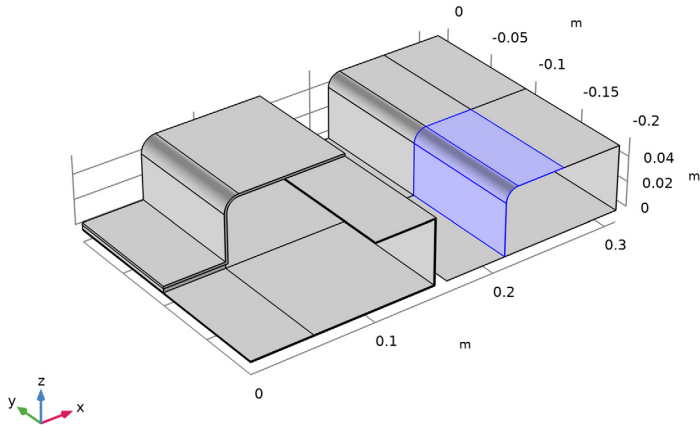

- 3 In the **Settings** window for **Delete Entities**, click **Build Selected**.

*Work Plane 2 (wp2)*

- 1 In the **Geometry** toolbar, click **Work Plane**.
- 2 In the **Settings** window for **Work Plane**, locate the **Plane Definition** section.
- 3 From the **Plane type** list, choose **Face parallel**.

4 On the object **del2**, select Boundary 14 only.

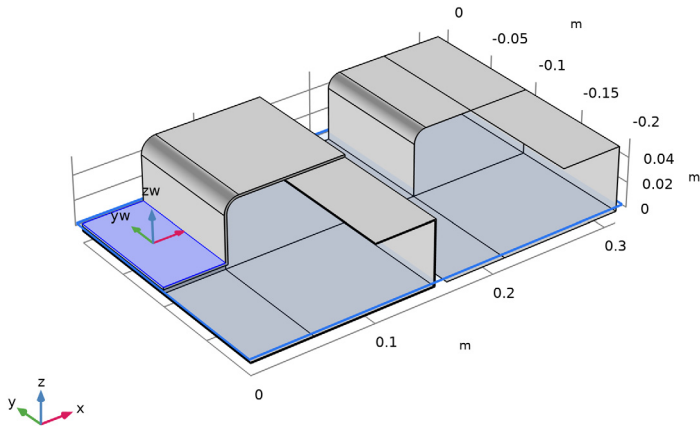

#### Plane Geometry

In the **Model Builder** window, click **Plane Geometry**.

#### Work Plane 2 (wp2)>Rectangle 1 (r1)

- 1 In the **Work Plane** toolbar, click **Rectangle**.
- 2 In the **Settings** window for **Rectangle**, locate the **Size and Shape** section.
- 3 In the **Width** text field, type 0.01.
- 4 In the **Height** text field, type 0.01.
- 5 Locate the **Position** section. In the **xw** text field, type -0.025.
- 6 In the **yw** text field, type -0.005.

#### Work Plane 2 (wp2)

- 1 In the **Model Builder** window, click **Work Plane 2 (wp2)**.
- 2 In the **Settings** window for **Work Plane**, locate the **Selections of Resulting Entities** section.
- 3 Select the **Resulting objects selection** check box.
- 4 In the **Label** text field, type Feeding surface in Volumetric Geometry.
- 5 Click **Build Selected**.

#### Copy 1 (copy1)

- 1 In the **Geometry** toolbar, click **Transforms** and choose **Copy**.

- 2 Select the object **wp2** only.
- 3 In the **Settings** window for **Copy**, locate the **Displacement** section.
- 4 In the **x** text field, type 0.16.
- 5 In the **z** text field, type  $-\text{Cu\_thickness}-\text{Air\_thickness}-\text{Al\_thickness}$ .
- 6 In the **Label** text field, type Feeding surface in Shell Geometry.
- 7 Locate the **Selections of Resulting Entities** section. Select the **Resulting objects selection** check box.
- 8 Click **Build All Objects**.
- 9 Click the **Zoom Extents** button in the **Graphics** toolbar.

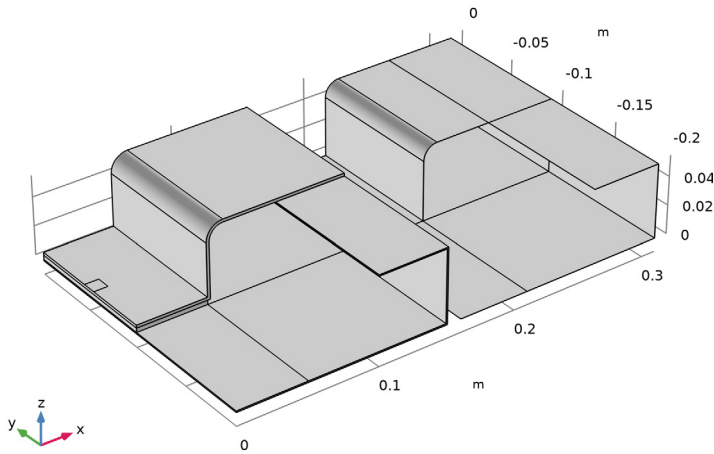

## MATERIALS

### *Material Link 1 (matlnk1)*

- 1 In the **Model Builder** window, under **Component 1 (comp1)** right-click **Materials** and choose **More>Material Link**.
- 2 In the **Settings** window for **Material Link**, type Solid: Air in the **Label** text field.
- 3 Select Domain 3 only.

### *Material Link 2 (matlnk2)*

- 1 Right-click **Materials** and choose **More>Material Link**.
- 2 In the **Settings** window for **Material Link**, type Solid: Aluminum in the **Label** text field.

- 3 Locate the **Link Settings** section. From the **Material** list, choose **Aluminum (mat2)**.
- 4 Select Domain 4 only.

*Material Link 3 (matlnk3)*

- 1 Right-click **Materials** and choose **More>Material Link**.
- 2 In the **Settings** window for **Material Link**, type Solid: Copper in the **Label** text field.
- 3 Locate the **Link Settings** section. From the **Material** list, choose **Copper (mat3)**.
- 4 Select Domains 1 and 2 only.

*Material Link 4 (matlnk4)*

- 1 Right-click **Materials** and choose **More>Material Link**.
- 2 In the **Settings** window for **Material Link**, type Solid: Semiconductive Material in the **Label** text field.
- 3 Locate the **Link Settings** section. From the **Material** list, choose **Semiconductive Material (mat4)**.
- 4 Select Domain 5 only.

*Layered Material Link 1 (llmat1)*

- 1 Right-click **Materials** and choose **Layers>Layered Material Link**.
- 2 In the **Settings** window for **Layered Material Link**, type Shell: Al-Air-Cu in the **Label** text field.
- 3 Select Boundaries 50 and 51 only.
- 4 Locate the **Orientation and Position** section. From the **Position** list, choose **User defined**.
- 5 In the **Relative midplane offset** text field, type  $-(Cu\_thickness+Air\_thickness) / (Cu\_thickness+Air\_thickness+Al\_thickness)$ .

In a COMSOL geometry, all boundaries are equipped with a *surface normal*. The surface normal is a unit vector that is tied to what is considered the upside and downside of the boundary. For layered materials, the normal vector dictates the direction in which the layers are stacked. When an offset is specified, the layer stack is shifted in the direction of the surface normal. Although the shift will not affect the solution (as curvature is neglected), it does affect how the layers are displayed in postprocessing.

*Layered Material Link 2 (llmat2)*

- 1 Right-click **Materials** and choose **Layers>Layered Material Link**.
- 2 In the **Settings** window for **Layered Material Link**, type Shell: Cu-Semi-Al in the **Label** text field.

- 3 Locate the **Layered Material Settings** section. From the **Material** list, choose **Cu-Semi-Al Stack (Imat2)**.
- 4 Select Boundary 58 only.
- 5 Locate the **Orientation and Position** section. From the **Position** list, choose **Downside on boundary**.
- 6 In the **Home** toolbar, click **Windows** and choose **Add Material from Library**.

#### ADD MATERIAL

- 1 Go to the **Add Material** window.
- 2 In the tree, select **Built-in>Aluminum** and **Built-in>Copper**.
- 3 Click **Add to Component 1 (comp1)**.

#### MATERIALS

##### *Aluminum (mat5)*

- 1 In the **Model Builder** window, under **Component 1 (comp1)>Materials** click **Aluminum (mat5)**.
- 2 In the **Settings** window for **Material**, locate the **Geometric Entity Selection** section.
- 3 From the **Geometric entity level** list, choose **Boundary**.
- 4 Click to expand the **Material Properties** section. In the **Material properties** tree, select **Geometric Properties>Shell**.
- 5 Click **Add to Material**.
- 6 In the **Model Builder** window, expand the **Aluminum (mat5)** node, then click **Shell (shell)**.
- 7 In the **Settings** window for **Property Group**, locate the **Layer Definition** section.
- 8 In the **Thickness** text field, type `Al_thickness`.
- 9 In the **Model Builder** window, click **Aluminum (mat5)**.
- 10 In the **Settings** window for **Material**, type `Shell: Al` in the **Label** text field.
- 11 Select Boundaries 53, 55, and 56 only.
- 12 Locate the **Orientation and Position** section. From the **Position** list, choose **User defined**.
- 13 In the **Relative midplane offset** text field, type `1+2*(Semi_thickness+Cu_thickness)/Al_thickness`.

##### *Copper (mat6)*

- 1 In the **Model Builder** window, click **Copper (mat6)**.
- 2 In the **Settings** window for **Material**, locate the **Geometric Entity Selection** section.

- 3 From the **Geometric entity level** list, choose **Boundary**.
- 4 Click to expand the **Material Properties** section. In the **Material properties** tree, select **Geometric Properties>Shell**.
- 5 Click **Add to Material**.
- 6 In the **Model Builder** window, expand the **Copper (mat6)** node, then click **Shell (shell)**.
- 7 In the **Settings** window for **Property Group**, locate the **Layer Definition** section.
- 8 In the **Thickness** text field, type `Cu_thickness`.
- 9 In the **Model Builder** window, click **Copper (mat6)**.
- 10 In the **Settings** window for **Material**, type `Shell: Cu` in the **Label** text field.
- 11 Select Boundaries 49, 52, 54, 57, 59, and 60 only.
- 12 Locate the **Orientation and Position** section. From the **Position** list, choose **Downside on boundary**.

#### **ELECTRIC CURRENTS (EC)**

- 1 In the **Model Builder** window, under **Component 1 (comp1)** click **Electric Currents (ec)**.
- 2 In the **Settings** window for **Electric Currents**, locate the **Domain Selection** section.
- 3 In the list, select **3**.
- 4 Click **Remove from Selection**.
- 5 Select Domains 1, 2, 4, and 5 only.

#### *Ground 1*

- 1 In the **Physics** toolbar, click **Boundaries** and choose **Ground**.
- 2 Click the **Zoom Extents** button in the **Graphics** toolbar.
- 3 Select Boundaries 1 and 5 only.
- 4 Click the **Zoom Extents** button in the **Graphics** toolbar.

#### *Terminal 1*

- 1 In the **Physics** toolbar, click **Boundaries** and choose **Terminal**.
- 2 In the **Settings** window for **Terminal**, locate the **Terminal** section.
- 3 In the  $I_0$  text field, type 1.
- 4 Select Boundary 15 only.
- 5 Click the **Zoom Extents** button in the **Graphics** toolbar.

## **ELECTRIC CURRENTS IN LAYERED SHELLS (ECIS)**

- 1 In the **Model Builder** window, under **Component 1 (comp1)** click **Electric Currents in Layered Shells (ecis)**.
- 2 In the **Settings** window for **Electric Currents in Layered Shells**, locate the **Boundary Selection** section.
- 3 Select the **Restrict to layered boundaries** check box.

### *Conductive Shell 1*

In the **Model Builder** window, expand the **Component 1 (comp1)**>**Electric Currents in Layered Shells (ecis)**>**Conductive Shell 1** node, then click **Conductive Shell 1**.

### *Terminal 1*

- 1 In the **Physics** toolbar, click **Attributes** and choose **Terminal**.
- 2 In the **Settings** window for **Terminal**, locate the **Boundary Selection** section.
- 3 From the **Selection** list, choose **Manual**.
- 4 Select Boundary 51 only.
- 5 Locate the **Interface Selection** section. From the **Apply to** list, choose **Bottom interface**.
- 6 Locate the **Terminal** section. In the  $I_0$  text field, type 1.

### *Ground 1*

- 1 In the **Physics** toolbar, click **Edges** and choose **Ground**.
- 2 Select Edges 107, 109, and 111 only.
- 3 In the **Settings** window for **Ground**, locate the **Shell Properties** section.
- 4 Clear the **Use all layers** check box.
- 5 Specify the **Selection** vector as

	Al
	Air
√	Cu

### *Ground 2*

- 1 In the **Physics** toolbar, click **Edges** and choose **Ground**.
- 2 Select Edge 105 only.

### *Continuity 1*

- 1 In the **Physics** toolbar, click **Edges** and choose **Continuity**.



- 2 In the **Settings** window for **Continuity**, locate the **Layer Selection** section.
- 3 From the **Source** list, choose **Shell: Al-Air-Cu (lmat1)-[lmat1]**.
- 4 From the **Destination** list, choose **Shell: Al (mat5)**.

#### *Continuity 2*

- 1 In the **Physics** toolbar, click **Edges** and choose **Continuity**.
- 2 In the **Settings** window for **Continuity**, locate the **Layer Selection** section.
- 3 From the **Source** list, choose **Shell: Al-Air-Cu (lmat1)-[lmat1]**.
- 4 From the **Destination** list, choose **Shell: Cu (mat6)**.
- 5 In the **Selection** table, enter the following settings:

	<b>Layered material</b>	<b>Offset (m)</b>
√	Shell: Cu (mat6)	0

#### *Continuity 3*

- 1 In the **Physics** toolbar, click **Edges** and choose **Continuity**.
- 2 In the **Settings** window for **Continuity**, locate the **Layer Selection** section.
- 3 From the **Source** list, choose **Shell: Cu-Semi-Al (lmat2)-[lmat2]**.
- 4 From the **Destination** list, choose **Shell: Al (mat5)**.
- 5 In the **Selection** table, enter the following settings:

	<b>Layered material</b>	<b>Offset (m)</b>
√	Shell: Al (mat5)	0

#### *Continuity 4*

- 1 In the **Physics** toolbar, click **Edges** and choose **Continuity**.
- 2 In the **Settings** window for **Continuity**, locate the **Layer Selection** section.
- 3 From the **Source** list, choose **Shell: Cu-Semi-Al (lmat2)-[lmat2]**.
- 4 From the **Destination** list, choose **Shell: Cu (mat6)**.

#### *Insulating Layer 1*

- 1 In the **Physics** toolbar, click **Boundaries** and choose **Insulating Layer**.
- 2 In the **Settings** window for **Insulating Layer**, locate the **Boundary Selection** section.
- 3 From the **Selection** list, choose **All boundaries**.

4 Locate the **Shell Properties** section. Specify the **Selection** vector as

	Al
√	Air
	Cu

#### **MESH 1**

##### *Free Tetrahedral 1*

- 1 In the **Model Builder** window, under **Component 1 (comp1)** right-click **Mesh 1** and choose **Free Tetrahedral**.
- 2 In the **Settings** window for **Free Tetrahedral**, locate the **Domain Selection** section.
- 3 From the **Geometric entity level** list, choose **Domain**.
- 4 Select Domains 1 and 2 only.
- 5 Click **Build Selected**.

##### *Swept 1*

- 1 In the **Model Builder** window, right-click **Mesh 1** and choose **Swept**.
- 2 In the **Settings** window for **Swept**, locate the **Domain Selection** section.
- 3 From the **Geometric entity level** list, choose **Domain**.
- 4 Select Domain 5 only.
- 5 Click **Build Selected**.

##### *Free Tetrahedral 2*

- 1 Right-click **Mesh 1** and choose **Free Tetrahedral**.
- 2 In the **Settings** window for **Free Tetrahedral**, locate the **Domain Selection** section.
- 3 From the **Geometric entity level** list, choose **Domain**.
- 4 Select Domain 4 only.
- 5 Click the **Zoom Extents** button in the **Graphics** toolbar.
- 6 Click **Build Selected**.
- 7 Click the **Zoom Extents** button in the **Graphics** toolbar.

##### *Free Triangular 1*

- 1 Right-click **Mesh 1** and choose **More Operations>Free Triangular**.
- 2 Select Boundaries 49–60 only.

### *Size 1*

- 1 Right-click **Free Triangular 1** and choose **Size**.
- 2 In the **Settings** window for **Size**, locate the **Element Size** section.
- 3 Click the **Custom** button.
- 4 Locate the **Element Size Parameters** section. Select the **Maximum element size** check box.
- 5 Select the **Minimum element size** check box.
- 6 In the **Maximum element size** text field, type 0.005.
- 7 In the **Minimum element size** text field, type 0.005.
- 8 Click **Build All**.

For the solid representation, there is one unique expression for the electric potential:  $V$ . For the layered shell representation however, there are several (depending on which side of the boundary you are):  $ecis.Vup$ ,  $ecis.Vdown$ , and  $ecis.Vav$ . As certain parts of the shell geometry show material discontinuities and varying definitions of the surface normal, the appropriate expression to use in the plot differs from place to place. In order to simplify postprocessing, we define a couple of intermediate variables.

The battery charging and discharging variables are set up as follows:

For the solid representation, there is one unique expression for the electric potential:  $V$ . For the layered shell representation however, there are several (depending on which side of the boundary you are):  $ecis.Vup$ ,  $ecis.Vdown$ , and  $ecis.Vav$ . As certain parts of the shell geometry show material discontinuities and varying definitions of the surface normal, the appropriate expression to use in the plot differs from place to place. In order to simplify postprocessing, we define a couple of intermediate variables.

The battery charging and discharging variables are set up as follows:

## **DEFINITIONS (COMPI)**

### *Variables 1*

- 1 In the **Model Builder** window, under **Component 1 (comp1)** right-click **Definitions** and choose **Variables**.
- 2 In the **Settings** window for **Variables**, locate the **Geometric Entity Selection** section.
- 3 From the **Geometric entity level** list, choose **Boundary**.
- 4 Select Boundaries 50, 51, and 54 only.

5 Locate the **Variables** section. In the table, enter the following settings:

Name	Expression	Unit	Description
V_Al	ecis.Vdown	V	Electric potential in the aluminum layer
V_Cu	ecis.Vup	V	Electric potential in the copper layer

Notice that the normal of these boundaries is pointed down (in the minus  $z$  direction).

#### Variables 2

- 1 Right-click **Definitions** and choose **Variables**.
- 2 In the **Settings** window for **Variables**, locate the **Geometric Entity Selection** section.
- 3 From the **Geometric entity level** list, choose **Boundary**.
- 4 Select Boundary 58 only.
- 5 Locate the **Variables** section. In the table, enter the following settings:

Name	Expression	Unit	Description
V_Al	ecis.Vup	V	Electric potential in the aluminum layer
V_Cu	ecis.Vdown	V	Electric potential in the copper layer

#### Variables 3

- 1 Right-click **Definitions** and choose **Variables**.
- 2 In the **Settings** window for **Variables**, locate the **Geometric Entity Selection** section.
- 3 From the **Geometric entity level** list, choose **Boundary**.
- 4 Select Boundaries 53, 55, and 56 only.
- 5 Locate the **Variables** section. In the table, enter the following settings:

Name	Expression	Unit	Description
V_Al	ecis.Vav	V	Electric potential in the aluminum layer

#### Variables 4

- 1 Right-click **Definitions** and choose **Variables**.
- 2 In the **Settings** window for **Variables**, locate the **Geometric Entity Selection** section.
- 3 From the **Geometric entity level** list, choose **Boundary**.
- 4 Select Boundaries 49, 52, 57, 59, and 60 only.

5 Locate the **Variables** section. In the table, enter the following settings:

Name	Expression	Unit	Description
V_Cu	ecis.Vav	V	Electric potential in the copper layer

### STUDY I

In the **Home** toolbar, click **Compute**.

### RESULTS

#### *Multislice 1*

- 1 In the **Model Builder** window, expand the **Electric Potential (ec)** node, then click **Multislice 1**.
- 2 In the **Settings** window for **Multislice**, locate the **Multiphase Data** section.
- 3 Find the **Y-planes** subsection. In the **Planes** text field, type 18.
- 4 In the **Electric Potential (ec)** toolbar, click **Plot**.

#### *Electric Potential (ecis)*

- 1 In the **Model Builder** window, click **Electric Potential (ecis)**.
- 2 In the **Settings** window for **3D Plot Group**, locate the **Plot Settings** section.
- 3 Clear the **Plot dataset edges** check box.

The default plot **Electric Potential (ecis)** shows the electric potential in the shell. In addition to this, add the electric potential in the solid.

#### *Volume 1*

- 1 Right-click **Electric Potential (ecis)** and choose **Volume**.
- 2 In the **Settings** window for **Volume**, type Solid Electric Potential in the **Label** text field.
- 3 Locate the **Data** section. From the **Dataset** list, choose **Study 1/Solution 1 (sol1)**.
- 4 Click to expand the **Inherit Style** section. From the **Plot** list, choose **Surface 1**.
- 5 Click the **Show Grid** button in the **Graphics** toolbar.
- 6 In the **Electric Potential (ecis)** toolbar, click **Plot**.

In the following part, we create a plot for the electric potential along a set of selected paths for both the solid and the shell description. Start by defining the edges used for the comparison.

### DEFINITIONS (COMPI)

#### *Explicit 1*

- 1 In the **Definitions** toolbar, click **Explicit**.
- 2 In the **Settings** window for **Explicit**, type Solid Path A in the **Label** text field.
- 3 Locate the **Input Entities** section. From the **Geometric entity level** list, choose **Edge**.
- 4 Select Edges 24, 41, 50, 55, 70–72, and 81 only.
- 5 Click the **Zoom to Selection** button in the **Graphics** toolbar.
- 6 Click the **Wireframe Rendering** button in the **Graphics** toolbar.

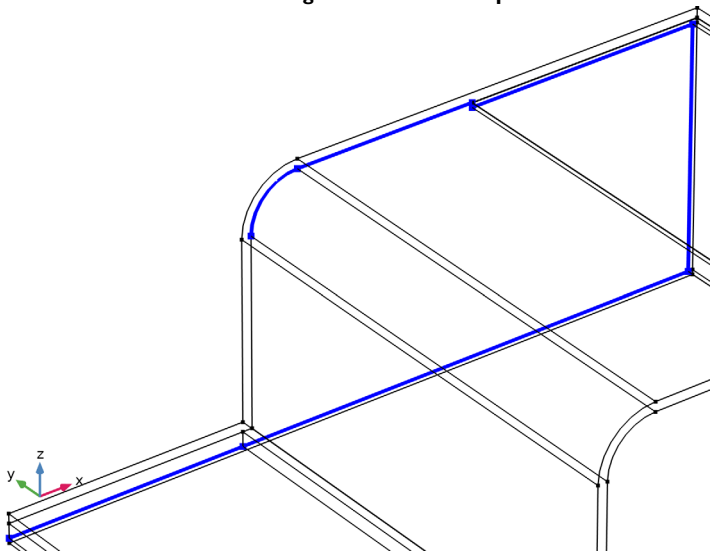

- 7 Click the **Zoom Extents** button in the **Graphics** toolbar.

#### *Explicit 2*

- 1 In the **Definitions** toolbar, click **Explicit**.
- 2 In the **Settings** window for **Explicit**, type Solid Path B in the **Label** text field.
- 3 Locate the **Input Entities** section. From the **Geometric entity level** list, choose **Edge**.
- 4 Select Edges 22, 44, 56, and 100–104 only.

5 Click the **Zoom to Selection** button in the **Graphics** toolbar.

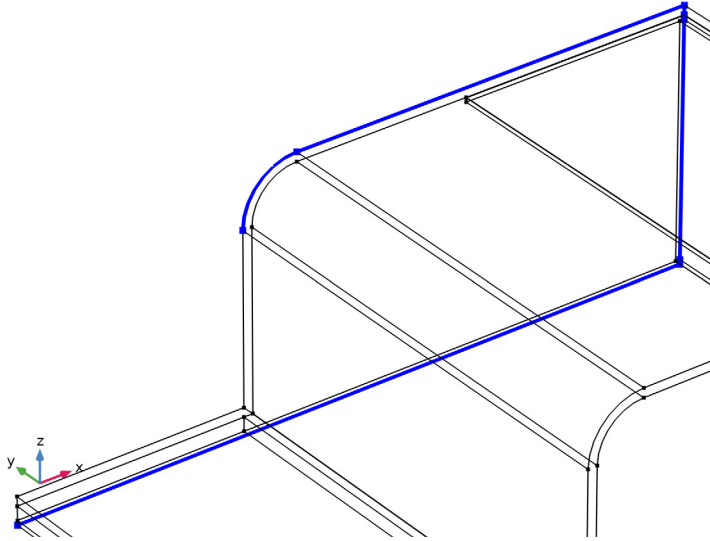

6 Click the **Zoom Extents** button in the **Graphics** toolbar.

### *Explicit 3*

- 1 In the **Definitions** toolbar, click **Explicit**.
- 2 In the **Settings** window for **Explicit**, type `She11 Path A-B` in the **Label** text field.
- 3 Locate the **Input Entities** section. From the **Geometric entity level** list, choose **Edge**.
- 4 Select Edges 113, 123, 124, 127, 132, and 139 only.

5 Click the **Zoom to Selection** button in the **Graphics** toolbar.

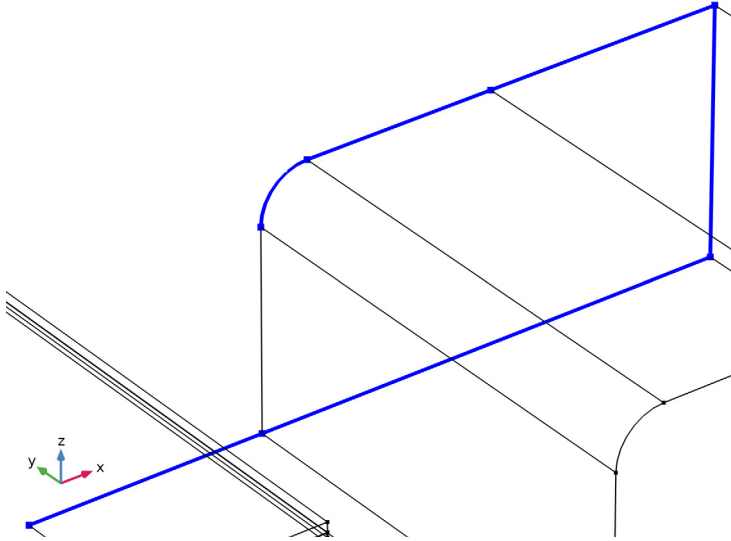

Next, add the layered shell variables for path A and path B. They are entered in the same way as done for the aluminum and the copper.

#### *Variables 1*

- 1 In the **Model Builder** window, click **Variables 1**.
- 2 In the **Settings** window for **Variables**, locate the **Variables** section.
- 3 In the table, enter the following settings:

Name	Expression	Unit	Description
V_A	V_Cu	V	Electric potential path A
V_B	V_Cu	V	Electric potential path B

#### *Variables 2*

- 1 In the **Model Builder** window, click **Variables 2**.
- 2 In the **Settings** window for **Variables**, locate the **Variables** section.
- 3 In the table, enter the following settings:

Name	Expression	Unit	Description
V_A	V_Cu	V	Electric potential path A
V_B	V_Al	V	Electric potential path B



### Variables 3

- 1 In the **Model Builder** window, click **Variables 3**.
- 2 In the **Settings** window for **Variables**, locate the **Variables** section.
- 3 In the table, enter the following settings:

Name	Expression	Unit	Description
V_A	V_A1	V	Electric potential path A
V_B	V_A1	V	Electric potential path B

### Variables 4

- 1 In the **Model Builder** window, click **Variables 4**.
- 2 In the **Settings** window for **Variables**, locate the **Variables** section.
- 3 In the table, enter the following settings:

Name	Expression	Unit	Description
V_A	V_Cu	V	Electric potential path A
V_B	V_Cu	V	Electric potential path B

Since you have introduced a couple of new variables, the solution should be updated. After that, continue by introducing the 1D plot group for the solid-shell comparison.

## STUDY 1

In the **Study** toolbar, click **Update Solution**.

## RESULTS

### 1D Plot Group 3

- 1 In the **Home** toolbar, click **Add Plot Group** and choose **ID Plot Group**.
- 2 In the **Settings** window for **ID Plot Group**, type Solid-Shell Comparison in the **Label** text field.
- 3 Click to expand the **Title** section. From the **Title type** list, choose **Manual**.
- 4 In the **Title** text area, type Solid-Shell Comparison.
- 5 Locate the **Plot Settings** section. Select the **y-axis label** check box.
- 6 In the associated text field, type Electric potential (V).
- 7 Locate the **Legend** section. From the **Position** list, choose **Upper left**.

### Line Graph 1

- 1 Right-click **Solid-Shell Comparison** and choose **Line Graph**.

- 2 In the **Settings** window for **Line Graph**, locate the **Selection** section.
- 3 From the **Selection** list, choose **Solid Path A**.
- 4 Click to expand the **Coloring and Style** section. From the **Color** list, choose **Blue**.
- 5 Click to expand the **Legends** section. Select the **Show legends** check box.
- 6 From the **Legends** list, choose **Manual**.
- 7 In the table, enter the following settings:

<b>Legends</b>
Solid 3D Path A

#### *Line Graph 2*

- 1 In the **Model Builder** window, right-click **Solid-Shell Comparison** and choose **Line Graph**.
- 2 In the **Settings** window for **Line Graph**, locate the **Selection** section.
- 3 From the **Selection** list, choose **Shell Path A-B**.
- 4 Locate the **y-Axis Data** section. In the **Expression** text field, type **V\_A**.
- 5 Locate the **Coloring and Style** section. From the **Color** list, choose **Blue**.
- 6 Find the **Line style** subsection. From the **Line** list, choose **None**.
- 7 Find the **Line markers** subsection. From the **Marker** list, choose **Circle**.
- 8 In the **Number** text field, type **28**.
- 9 Locate the **Legends** section. Select the **Show legends** check box.
- 10 From the **Legends** list, choose **Manual**.
- 11 In the table, enter the following settings:

<b>Legends</b>
Layered Shell Path A

#### *Line Graph 3*

- 1 Right-click **Solid-Shell Comparison** and choose **Line Graph**.
- 2 In the **Settings** window for **Line Graph**, locate the **Selection** section.
- 3 From the **Selection** list, choose **Solid Path B**.
- 4 Locate the **Coloring and Style** section. From the **Color** list, choose **Red**.
- 5 Locate the **Legends** section. Select the **Show legends** check box.
- 6 From the **Legends** list, choose **Manual**.

7 In the table, enter the following settings:

---

**Legends**

---

Solid 3D Path B

---

*Line Graph 4*

- 1 Right-click **Solid-Shell Comparison** and choose **Line Graph**.
- 2 In the **Settings** window for **Line Graph**, locate the **Selection** section.
- 3 From the **Selection** list, choose **Shell Path A-B**.
- 4 Locate the **y-Axis Data** section. In the **Expression** text field, type  $V_B$ .
- 5 Locate the **Coloring and Style** section. From the **Color** list, choose **Red**.
- 6 Find the **Line style** subsection. From the **Line** list, choose **None**.
- 7 Find the **Line markers** subsection. From the **Marker** list, choose **Asterisk**.
- 8 In the **Number** text field, type 30.
- 9 Locate the **Legends** section. Select the **Show legends** check box.
- 10 From the **Legends** list, choose **Manual**.
- 11 In the table, enter the following settings:

---

**Legends**

---

Layered Shell Path B

---

*Solid-Shell Comparison*

The results for the solid representation and the layered shell are in agreement. Notice that this agreement requires layers that are sufficiently thin. The thinner the layer, the better the agreement.

Finally, modify the **Electric Potential (ecis)** plot to show a clear comparison between the solid representation and the layered shell representation.

*Line 1*

- 1 In the **Model Builder** window, right-click **Electric Potential (ecis)** and choose **Line**.
- 2 In the **Settings** window for **Line**, locate the **Data** section.
- 3 From the **Dataset** list, choose **Study 1/Solution 1 (sol1)**.
- 4 Locate the **Expression** section. In the **Expression** text field, type 1.
- 5 Locate the **Coloring and Style** section. From the **Coloring** list, choose **Uniform**.
- 6 From the **Color** list, choose **Black**.

### *Deformation 1*

- 1** Right-click **Line 1** and choose **Deformation**.
- 2** In the **Settings** window for **Deformation**, locate the **Expression** section.
- 3** In the **X component** text field, type 0.
- 4** In the **Y component** text field, type 0.
- 5** In the **Z component** text field, type 0.07.
- 6** Locate the **Scale** section. Select the **Scale factor** check box.
- 7** In the associated text field, type 1.
- 8** Click the **Go to XZ View** button in the **Graphics** toolbar.
- 9** Click the **Orthographic Projection** button in the **Graphics** toolbar.
- 10** Click the **Zoom Extents** button in the **Graphics** toolbar.
- 11** In the **Electric Potential (ecis)** toolbar, click **Plot**.